

CHAPTER 1 SPECIFICATIONS

1.1	OVERVIEW.....	1
1.2	PRODUCT NAME AND MODEL	1
1.2.1	Name.....	1
1.2.2	Name for sales	1
1.2.3	Name for export	1
1.2.4	Models.....	1
1.2.5	Product Structure Code (PS code) and goods item code	1
1.3	CLASSIFICATION.....	2
1.4	TERMINOLOGY	2
1.5	SYSTEM ORGANIZATION	2
1.5.1	Configuration and expandabilities to systems.....	2
1.5.1.1	Configuration	2
1.5.1.2	Expandability for system (peripheral equipment)	2
1.5.1.3	Expandability for system(software).....	3
1.5.2	Electrical Rating	3
1.5.3	Dimensions and Weight	3
1.5.4	Measurement Principle(Process flow, detection principle).....	4
1.6	SPECIFICATIONS AND FUNCTIONS.....	5
1.6.1	Intended Use.....	5
1.6.2	Specification	5
1.6.2.1	Analysis Parameter and Display	5
1.6.2.2	Analysis and Display Range.....	6
1.6.2.3	Reproducibility	7
1.6.2.4	Accuracy.....	8
1.6.2.5	Linearity.....	9
1.6.2.6	Carryover.....	9
1.6.2.7	Stability	9
1.6.2.8	Throughput.....	11
1.6.2.9	Required Sample and Reagent volume	12
1.6.3	Functions.....	13
1.6.3.1	Select Function.....	13
1.6.3.2	Input	13
1.6.3.3	Display Function.....	13
1.6.3.4	Data storage	14
1.6.3.5	Timer (Sleep) function	14
1.6.3.6	Biohazard function.....	14
1.6.3.7	Printer (Built-in Printer).....	15
1.6.3.8	Serial Interface	15
1.6.3.9	Calendar and Clock.....	15

1.6.3.10 Histogram Analysis.....	15
1.6.3.11 Quality Control.....	15
1.6.3.12 Calibration	16
1.6.3.13 Abnormality Detection Function	16
1.6.3.14 START-UP	17
1.6.3.15 SHUT DOWN	17
1.6.3.16 Service Maintenance.....	17
1.6.3.17 Safety Protection	18
1.6.3.18 Reagent Control (exclude XP-100 for China market).....	19
1.7 TRACEABILITY	19
1.8 REQUIREMENTS	19
1.8.1 Environmental Requirements.....	19
1.8.2 Electric Source	20
1.8.3 Reagents.....	20
1.9 OPERATION AND MAINTENANCE	20
1.9.1 Operation	20
1.9.2 Supply	20
1.9.3 Maintenance.....	21
1.10 PACKAGING.....	21
1.11 ATTACHMENTS.....	21
1.11.1Accessories.....	21
1.12 REQUIRED CONDITIONS	21
1.12.1Environmental Conditions	21
1.13 ACOUSTIC NOISE	22
1.14 EXPECTED LIFE TIME	22

CHAPTER 1 SPECIFICATIONS

1.1 OVERVIEW

Automated Hematology Analyzer XP series is succession machine of KX-21 that more than 10 years have passed since its introduction to the market. The purpose of XP series development is to expand business relations in developing nations. Only essential changes implemented from KX-21/KX-21N to XP series, and its hardware, sequence software and appearance are designed based on KX-21N, and basic software is designed based on pocH-100i and silent design.

While XP series inherited the basic performance and functions of KX-21N and pocH-100i, its specification has been enhanced with changes as follows.

- Increase the number of stored data (40,000 items (XP-300))
- Adopt color touchpad display
- Expand SNCS functionality
- Add PCT (Platelet count) to analysis items
- Add reagent management function (Unique barcode)
- Increase available languages (Russian, Indonesian and Korean)

1.2 PRODUCT NAME AND MODEL

1.2.1 Name

Automated Hematology Analyzer (JMDN Code: 35476000)

1.2.2 Name for sales

Automated Hematology Analyzer XP series

1.2.3 Name for export

Automated Hematology Analyzer XP series

1.2.4 Models

XP-100/XP-300

1.2.5 Product Structure Code (PS code) and goods item code

PS code	Name	JAN Code	UPC code
AP807129	XP-300 COMPLETE(EU/230V)	4987562429172	636090429171
AJ213506	XP-300 COMPLETE(UK/240V)	4987562429189	636090429188
BG491812	XP-300 COMPLETE(CHN/220V)	4987562429196	636090429195
BL783052	XP-300 COMPLETE(JP/100V)	4987562429202	636090429201
AR408878	XP-300 COMPLETE(EXP/120V)	4987562429219	636090429218
BS649542	XP-100 COMPLETE(EU/230V)	4987562429226	636090429225
AQ088754	XP-100 COMPLETE(UK/240V)	4987562429233	636090429232
BN167486	XP-100 COMPLETE(CHN/220V)	4987562429240	636090429249

1.3 CLASSIFICATION

Classification Class: Class I

1.4 TERMINOLOGY

- Whole blood mode : mode that measures sample blood without dilution.
Pre-dilute mode : mode that measures sample blood that dilute by 26 times.
Service data : data that is used for production, technical service and scientific activities, but not provided to users.
Service function : function that is used for production, technical services and scientific activities, and not used by users.

1.5 SYSTEM ORGANIZATION

1.5.1 Configuration and expandabilities to systems

1.5.1.1 Configuration

(1) Units

Main unit (with data processing function, compressor, built-in lyse container)

* A common program that is used for XP-100 and XP-300 has installed on the main unit.

(2) Reagent

Diluent	CELLPACK
Lyse reagent	STROMATOLYSER-WH
Detergent	CELLCLEAN

(3) Control blood and Calibrator

Control blood	EIGHTCHECK-3WP, EIGHTCHECK 3WP X-TRA A
Calibrator	SCS-1000

(4) Reagent for gain adjustment

WBC, RBC	CELLCHECK-400
PLT	PLT Latex Calibrator(E)

1.5.1.2 Expandability for system (peripheral equipment)

- (1) Handy barcode reader (Option)
- (2) GP(Graphic print)/LP(Listed print)
- (3) RS-232C-LAN adaptor (for SNCS)

A 313B059

1.5.1.3 Expandability for system(software)

(1) SNCS

Main functionalities

Online QC, Real time error log, Emergency Error Notification, Screen Capture(Available to save 5 captures at maximum on SNCS server), Failure Prediction(Pressure 0.05Mpa/ Vacuum - 0.0333Mpa / Draining time of drain chamber, HGB Blank, Clogs), Parameter Backup, Operation Cycle Count log, Maintenance log

* As to failure prediction, data needs to be collected for verifications.

1.5.2 Electrical Rating

- 1) Rated Voltage
100V/120V/220V/230V/240V
- 2) AC/DC
AC
- 3) Frequency
50Hz or 60Hz
- 4) Maximum Rated Power
200VA
- 5) Protection Type
Class I equipment

1.5.3 Dimensions and Weight

- 1) Dimensions
Width 420mm
Height 480mm
Depth 355mm
- 2) Weight
Approx. 30kg

1.5.4 Measurement Principle(Process flow, detection principle)

- 1) Blood Quantative Method
Quantify with sampling valve(SRV).
- 2) Whole Blood Mode Dilution and Lysis
Aspirate approx. 50 μ L of blood with anti-coagulant and quantify with SRV. Prepare WBC/HGB sample and RBC/PLT sample by diluting with diluent and lyse agent by approx. 500 times and approx. 25000 times, respectively.

WBC/HGB sample (Approx. 500 times)
First dilution: 6.012 μ L blood + 2.0 mL Diluent + 1.0 mL lyse
RBC/PLT sample (Approx. 25000 times = 500x50)
First dilution: 4.008 μ L blood + 2.0mL diluent
Second dilution: 40.82 μ L First sample + 2.0 mL diluent
- 3) Pre-diluted Mode dilution
Aspirate approx. 200 μ L of pre-diluted sample that diluted with diluent by 26 times. Quantify the pre-diluted sample with sampling valve and prepare WBC/HGB sample and RBC/PLT sample by diluting by approx. 1000 times and approx. 25000, respectively. In Pre-diluted Mode, use a pore that is not used in Whole Blood Mode and the RBC/PLT sample dilution should be done at first dilution only.

WBC/HGB sample (Approx. 1000 times = 26x38.46)
First dilution: 26 times; 80.08 μ L PD sample + 2.0 mL diluent + 1.0 mL lyse
RBC/PLT sample (Approx. 25000 times = 26x961.5)
First dilution: 26 times; 2.082 μ L PD sample + 2.0 mL diluent
- 4) WBC measurement
Aspirate WBC/HGB sample 0.50mL through ϕ 100 μ m pore and measure with DC detection method. Diaphragm pump is used to aspirate and quantify.
- 5) RBC/PLT measurement
Aspirate 0.25mL of RBC/PLT sample through ϕ 75 μ m pore and measure with DC detection method. Diaphragm pump is used to aspirate and quantify. Analysis result is obtained by auto-discrimination of histograms.
- 6) HGB measurement
Measure absorption value of transmitted light at 555nm for diluent every measurement, and calculate HGB values that is determined by deducting the absorption value of transmitted light at 555nm for diluent from that for HGB sample(Colorimetric Method). LED and photodiode are used as a light source and a photo detector, respectively. Measurement method is SLS-Hb method.

1.6 SPECIFICATIONS AND FUNCTIONS

1.6.1 Intended Use

1) Purpose

The XP series is intended for in vitro diagnostic use, analyzing 20 parameters in anti-coagulated human blood. The Anti-coagulants are EDTA-2K, EDTA-3K and EDTA-2Na. The anti-coagulants volume conforms to CLSI standards.

Note: EDTA-2Na is not intended for North American markets. A

2) Workload

Expected workload is 60 samples/day.

1.6.2 Specification

1.6.2.1 Analysis Parameter and Display

(1) Analysis Mode

Whole Blood Mode
Pre-diluted Mode

(2) Measurement Parameters

White Blood corpuscle (WBC), Red Blood corpuscle (RBC), Hemoglobin (HGB), Hematocrit (HCT), Mean Red Blood Corpuscular Volume (MCV), Mean Corpuscular Hemoglobin (MCH), Mean Corpuscular Hemoglobin Concentration (MCHC), Platelet count (PLT)

(3) Analysis Parameters

WBC Small Cell Ratio (W-SCR), WBC Middle Cell Ratio (W-MCR), WBC Large Cell Ratio (W-LCR), WBC Small Cell Count (W-SCC), WBC Middle Cell Count (W-MCC), WBC Large Cell Count (W-LCC), RBC Distribution Width (RDW-SD, RDW-CV), Platelet Distribution Width (PDW), Mean Platelet Volume (MPV), Platelet Large Cell Ratio (P-LCR), Platelet Crit (PCT)

For N.A market, PDW, P-LCR and PCT are not output.

(4) Research Parameters

ResearchW, ResearchS, ResearchM, ResearchL

(5) Histograms

WBC/RBC/PLT

(6) Flags

Possible sample abnormalities are as follows.

- 1)WL, RL, PL : Relative height at Lower Discriminator exceeds the preset limit.
- 2)WU, RU, PU : Relative height at Upper Discriminator exceeds the preset limit.
- 3)DW : The RBC histogram does not cross the 20% height level twice.
- 4)MP : Two or more peaks exist in RBC or PLT histogram.
- 5)T1 : The trough discriminator cannot be set between SCR and MCR populations.
- 6)T2 : The trough discriminator cannot be set between MCR and LCR populations.
- 7)F1, F2, F3 : Relative height at the trough discriminator exceeds the preset limit.
- 8)AG : Too many cells exist at WBC Lower Discriminator and lower 2 channels.

A 313B059

1.6.2.2 Analysis and Display Range

Analysis and display range is shown in the table as follows. Note that Reportable Range in the table is intended for US markets only. A

Parameter	Analysis Range (Linearity Range)	Reportable Range A	Display Range
WBC	10 - 999 x 10 ² /μL	10 - 999 x 10 ² /μL	0 - 2999 x10 ² /μL
RBC	30 - 700 x10 ⁴ /μL	30 - 700 x10 ⁴ /μL	0 - 1999 x10 ⁴ /μL
HGB	0.1 - 25.0 g/dL	0.1 - 25.0 g/dL	0.0 - 25.0 g/dL
HCT	10.0- 60.0 %	10.0- 60.0	0.0 - 99.9 %
MCV	————	————	0.0 - 299.9fL
MCH	————	————	0.0 - 99.9 pg/dL
MCHC	————	————	0.0 - 99.9 g/dL
PLT	1.0 - 99.9 x10 ⁴ /μL	1.0 - 99.9	0.0 - 199.9 x10 ⁴ /μL
W-SCR	————	0.1 - 99.8	0.0 - 100.0 %
W-MCR	————	0.1 - 99.8	0.0 - 100.0 %
W-LCR	————	0.1 - 99.8	0.0 - 100.0 %
W-SCC	————	10 - 999	0 - 2999 x 10 ² /μL
W-MCC	————	10 - 999	0 - 2999 x 10 ² /μL
W-LCC	————	10 - 999	0 - 2999 x 10 ² /μL
RDW-CV	————	————	0.0 - 100.0 %
RDW-SD	————	————	0.0 - 250.0 fL
PDW	————	————	0.0 - 40.0 fL
MPV	————	————	0.0 - 40.0 fL
P-LCR	————	————	0.0 - 100.0 %
PCT	————	————	0.00 - 99.99 %
WBC Histogram	————	————	0 - 300 fL
RBC Histogram	————	————	0 - 250 fL
PLT Histogram	————	————	0 - 40 fL
ResearchW	————	————	0.00 - 2999.99 x10 ² /μL
ResearchS	————	————	0.00 - 2999.99 x10 ² /μL
ResearchM	————	————	0.00 - 2999.99 x10 ² /μL
ResearchL	————	————	0.00 - 2999.99 x10 ² /μL

A 313B059

1.6.2.3 Reproducibility

When fresh normal blood or control blood is analyzed in Whole Blood Mode 10 times consecutively, the variation of coefficient under 95% confidence interval should be within the following range:

Parameter	Condition	Whole Blood Mode	Pre-diluted Mode
WBC	40x10 ² /μL or more	3.5% or lower	6.0% or lower
RBC	400 x10 ⁴ /μL or more	2.0% or lower	3.0% or lower
HGB		1.5% or lower	2.5% or lower
HCT		2.0% or lower	3.0% or lower
MCV		2.0% or lower	3.0% or lower
MCH		2.0% or lower	3.0% or lower
MCHC		2.0% or lower	3.0% or lower
PLT	10x10 ⁴ /μL or more	6.0% or lower	9.0% or lower
W-SCR		15.0% or lower	25.0% or lower
W-MCR	W-MCR rate 12% or more	30.0% or lower	45.0% or lower
W-LCR		15.0% or lower	25.0% or lower
W-SCC		15.0% or lower	25.0% or lower
W-MCC	10x10 ² /μL or more	30.0% or lower	45.0% or lower
W-LCC		15.0% or lower	25.0% or lower
RDW-CV, RDW-SD		4.0% or lower	6.0% or lower
PDW		12.0% or lower	18.0% or lower
MPV		5.0% or lower	7.5% or lower
P-LCR		20.0% or lower	30.0% or lower
PCT		9.0% or lower	13.5% or lower

1.6.2.4 Accuracy

(1) For markets excluding North American markets **A**

When calibrator is analyzed 10 times consecutively, the mean difference from the value obtained on the standard instrument should be within the following range:

Parameter	Whole Blood Mode	Pre-diluted Mode
WBC	Within $\pm 3\%$ or $\pm 2 \times 10^2/\mu\text{L}$	Within $\pm 5\%$ or $\pm 3 \times 10^2/\mu\text{L}$
RBC	Within $\pm 2\%$ or $\pm 3 \times 10^4/\mu\text{L}$	Within $\pm 3\%$ or $\pm 5 \times 10^4/\mu\text{L}$
PLT	Within $\pm 5\%$ or $\pm 1.0 \times 10^4/\mu\text{L}$	Within $\pm 8\%$ or $\pm 1.5 \times 10^4/\mu\text{L}$

(2) For North American markets **A**

When the instrument is calibrated and 100 fresh blood samples or more are analyzed on the same day, the mean difference should be within the following range compared to the value obtained on calibrated KX-21 or KX21N instrument.

Parameter	Whole Blood Mode	Pre-diluted Mode
WBC	Within $\pm 3\%$ or $\pm 2 \times 10^7/\mu\text{L}$	$\pm 5\%$ or $\pm 3 \times 10^7/\mu\text{L}$
RBC	Within $\pm 2\%$ or $\pm 3 \times 10^7/\mu\text{L}$	$\pm 3\%$ or $\pm 5 \times 10^7/\mu\text{L}$
HGB	Within $\pm 2\%$ or ± 0.2 g/dL	—————
HCT	Within $\pm 3\%$ or ± 1.0 HCT%	—————
MCV	Within $\pm 5\%$	—————
MCH	Within $\pm 10\%$	—————
MCHC	$\pm 10\%$	—————
PLT	Within $\pm 5\%$ or $\pm 1.0 \times 10^7/\mu\text{L}$	$\pm 8\%$ or $\pm 1.5 \times 10^7/\mu\text{L}$
W-SCR	Within ± 5.0 W-SCR%	—————
W-MCR	Within ± 3.0 W-MCR%	—————
W-LCR	Within ± 5.0 W-LCR%	—————
RDW-CV	Within $\pm 10\%$	—————
RDW-SD	Within $\pm 10\%$	—————
MPV	Within $\pm 10\%$	—————

In regards to W-SCR, W-MCR and W-LCR, when the instrument is calibrated and 100 fresh blood samples or more are analyzed on the same day, the correlation coefficient should be in the following range compared to the value obtained on calibrated KX-21 or KX21N instrument. **A**

Parameter	Whole Blood Mode Correlation Coefficient
W-SCR	$r \geq 0.90$
W-MCR	$r \geq 0.70$
W-LCR	$r \geq 0.90$

A 313B059

1.6.2.5 Linearity

When the Whole Blood Manual Mode analysis is executed, the difference from the theoretical value should be within the following range:

Parameter	Concentration	Difference	Difference rate
WBC	10 - 99 x10 ² /μL 100 - 999 x10 ² /μL	Within ±3 x10 ² /μL	Within ±3 %
RBC	30 - 99 x10 ⁴ /μL 100 - 700 x10 ⁴ /μL	Within ±3 x10 ⁴ /μL	Within ±3 %
HGB	0.1 - 9.9 g/dL 10.0 - 25.0 g/dL	Within ±0.2 g/dL	Within ±2 %
HCT	10.0 - 33.3 % 33.4 - 60.0 %	Within ±1.0 HCT%	Within ±3 %
PLT	1.0 - 19.9 x10 ⁴ /μL 20.0 - 99.9 x10 ⁴ /μL (RBC<700 x10 ⁴ /μL)	Within ±1.0 x10 ⁴ /μL	Within ±5 %

1.6.2.6 Carryover

When control blood is analyzed in Whole Blood Mode, the carryover rate should be within the following range:

Parameter	Carryover rate
WBC	3 % or less
RBC	1.5% or less
HGB	1.5% or less
HCT	1.5% or less
PLT	5 % or less

1.6.2.7 Stability

When the Whole Blood Mode is executed, the stability should be within the following range:

(1) Stability relative to Temperature

In fresh normal blood or control blood analysis, the data fluctuation while the ambient temperature changes from 15°C to 30°C should be within the following range:

The following data are based on the assumption that the sample is analyzed within 12 hours after collection, and that any change in the sample should be executed from the fluctuation ratio.

Parameter	Fluctuation rate
WBC	Within 10% or 5.0x10 ² /μL
RBC, HGB, HCT	Within 5%
PLT	Within 15% or 3.0x10 ⁴ /μL

(2) Within-a-Day Stability

In control blood analysis of 5°C or less ambient temperature change, the data fluctuation for 24 hours after startup should be within the following range:

Parameter	Change rate
WBC	Within 10%
RBC, HGB, HCT	Within 5%
PLT	Within 15% or $3.0 \times 10^4 / \mu\text{L}$

(3) Day-to-Day Stability

In control blood analysis of 5°C or less ambient temperature change, the data fluctuation for ten days should be within following range:

Parameter	Change rate
WBC	Within 10%
RBC, HGB, HCT	Within 5%
PLT	Within 15% or $3.0 \times 10^4 / \mu\text{L}$

For North American markets, when control blood is analyzed in the whole blood mode in accordance with CLSI Document EP05-A2. Evaluation of Precision Performance of Quantitative Measurement Methods; Approved Guideline. 2004, Total Imprecision change rate calculated from data obtained should be in the following range. A

Parameter	Change rate
WBC	Within 6.0%
RBC	Within 3.0%
HGB	Within 2.5%
HCT	Within 3.0%
MCV	Within 3.0%
MCH	Within 3.0%
MCHC	Within 3.0%
PLT	Within 9.0%
W-SCR	Within 25.0%
W-MCR	Within 45.0%
W-LCR	Within 25.0%
W-SCC	Within 25.0%
W-MCC	Within 45.0%
W-LCC	Within 25.0%
RDW-CV	Within 6.0%
RDW-SD	Within 6.0%
MPV	Within 7.5%

A 313B059

(4) Stability relative to Power Supply Voltage

In control blood analysis of 5°C or less ambient temperature change, the data fluctuation while the power supply voltage changes ±10% from the rated voltage should be within the following range:

Parameter	Change rate
WBC	Within 10%
RBC, HGB, HCT	Within 5%
PLT	Within 15% or $3.0 \times 10^4 / \mu\text{L}$

(5) Sample Day-to-Day Stability (for North American markets only) A

In human blood analysis of 5°C or less ambient temperature change, the data fluctuation in 12 hours (human blood stored in room temperature (18-26 °C)) or 24 hours (human blood stored in cold storage (2-8 °C)) from blood sampling should be within the following range:

Parameter	Change rate
WBC	Within 10.0%
RBC	Within 5.0%
HGB	Within 5.0%
HCT	Within 5.0%
MCV	Within 10.0%
MCH	Within 10.0%
MCHC	Within 10.0%
PLT	Within 15.0%
W-SCR	Within 10 W-SCR%
W-MCR	Within 5 W-MCR%
W-LCR	Within 10 W-MCR%
RDW-CV	Within 15.0%
RDW-SD	Within 15.0%
MPV	Within 15.0%

1.6.2.8 Throughput

- (1) Time per sample : Approx. 60 seconds/sample
- (2) Throughput per hour : Approx. 60 samples/hour

A 313B059

1.6.2.9 Required Sample and Reagent volume

(1) Required Sample Volume

Whole Blood Mode : Approx. 50µL

Pre-diluted Mode : Approx. 20µL

(2) Required reagent volume

	Total reagent volume sample	Diluent sample	Lyse reagent sample
Whole Blood Mode	Approx. 35 mL	Approx. 34 mL	Approx. 1 mL
Pre-diluted Mode	Approx. 35 mL	Approx. 34 mL	Approx. 1 mL

1.6.2.10 Influence by inhibitor (for North American markets only) A

The data fluctuation as a result of influence by inhibitor (Whole blood mode) should be in the following range (in accordance with CLSI document H26-A2).

Parameter	Change rate
WBC	Within 10.9%
RBC	Within 3.2%
HGB	Within 2.8%
HCT	Within 2.8%
PLT	Within 9.1%

The density of inhibitor which satisfies the fluctuation above is as follows:

Inhibitor	Density
Bilirubin C (Conjugated)	Within 41.2 mg/dl
Bilirubin F (Free or Unconjugated)	Within 36.6 mg/dl
Hemolytic Hemoglobin	Within 974 mg/dl
Chyle	Within 2840 FTU
Intralipid	HGB: Within 2.9 OD(660nm) Other: Within 4 OD(660nm)

A 313B059

1.6.3 Functions

1.6.3.1 Select Function

Under standby mode, following processes can be executed from the select functions.

- (1) Stored data
- (2) Exchange reagent
- (3) Maintenance
- (4) Calibration
- (5) Setting
- (6) Gain adjustment
- (7) Service
- (8) Paper feed

1.6.3.2 Input

(1) Power switch

Turn on and off electrical power source

(2) Start switch

Aspirate from the whole blood pipette and start analysis.

(3) LCD touchpad

Pressing power switch, analysis start screen is displayed on LCD. Each operation can be selected on the LCD.

1) Sample ID

i) Manual input

Sample ID can be input before measurement execution.

ii) Auto input by barcode reader

Handy barcode reader is used to read barcode of sample ID that attached on sample tube automatically.

iii) Auto-increment

Sample ID is automatically incremented. This function can be disabled by setting.

2) Operator ID

Operator ID can be input before analysis start. This data can be set to disable.

(4) Handy Barcode Reader

Barcode Reader is used to read sample ID, reagent barcode and values of control blood.

1.6.3.3 Display Function

(1) Graphic LCD

Panel Specification

- i) Display system : STN Colour
- ii) Display dot : 320x240 dots(dot pitch: 0.36x0.36 mm)
- iii) Backlight : YES(CCFT)
- iv) Display Area : 115.17x86.37mm

Display Items

- i) Measurement results
 - Date/Time
 - Sample ID(Max: 15 digit)
 - Operator ID
 - Analysis results(Include flags and histograms)
 - * Analysis parameter display setting: for service purpose only
 - Measurement mode menu
 - Service data
- ii) System status
 - Error messages(Display numerical data in case of pressure errors.)
 - Instrument status
- iii) User operation
 - Menu (Maintenance, Settings, Adjustment...etc)

(2) Used Languages

Display	Languages
LCD Display	Japanese, English, Spanish, Portuguese, Russian, Mandarin, German, Italian, Indonesian and Korean
Printer Display	English

1.6.3.4 Data storage

- (1) Analysis Results 35,000 or more (Include histograms) (XP-100)
40,000 samples(Include histograms)(XP-300)
 - * Analysis Results Display Setting: for service purpose only
- (2) Quality Control Data 60points(in 6 files)
- (3) Setting Values
- (4) Maintenance data
 - i) Instrument Operation Cycle Count
 - ii) Unit Operation Cycle
 - Stores the number of operations after the replacement or maintenance of user maintenance units.
 - Not store the data on other units.
 - iii) Error history
 - Can be output to host computer, but not displayed on LCD.

1.6.3.5 Timer (Sleep) function

Stop compressor 15 minutes after completion of its operation

1.6.3.6 Biohazard function

Aspiration pipette wiping

1.6.3.7 Printer (Built-in Printer)

(1) Specifications

- i) Print method : Thermal printer
- ii) Paper : 58mm Thermal paper (57.5mm width)

(2) Printed Items

- i) Date/Time
- ii) Sample ID
- iii) Operator ID
- iv) Analysis results (Including flag and histogram)
* Analysis Result Display Setting: for service purpose only
- v) Histograms
- vi) Quality Control data
- vii) Setting values
- viii) Service data

1.6.3.8 Serial Interface

RS-232C, LAN(Ethernet)

- i) Latest sample analysis results
Analysis results, Flags, Histograms)
- ii) Stored data
Analysis results, Flags, Histograms
- iii) QC data
Analysis results, Flags, Histograms
- iv) SNCS relative data
Realtime online QC, Realtime log output, Image capture output, Failure prediction,
Backup parameter settings, Instrument log output including reagent exchange history etc...

1.6.3.9 Calendar and Clock

1.6.3.10 Histogram Analysis

Discriminator position on the latest analysis can be manually changed.

1.6.3.11 Quality Control

X-Bar Control or L-J Control

Up to 60 points of control data can be stored for 6 type of samples(in 6 files)

Up to 22 control parameters can be selected.

* 20 parameters for measurement and analysis + 2 sensitivity parameters(W-SMV, W-LMV)

For North America market, up to 17 parameters.

* Parameters for measurement and analysis excluding PDW,P-LCR,PCT

Judgement of control limit is executed based on control limit values that are set by manually or barcode.

Sample for quality control

: EIGHTCHECK-3WP, EIGHTCHECK-3WPEXTRA, EIGHTCHECK-C

1.6.3.12 Calibration

(1) Customer Calibration

- i) Calibration Method : Auto-calibration, Manual calibration and Calibrator calibration
- ii) Calibration Mode : Whole Blood Mode
- iii) Calibration Parameters: HGB, HCT only in case of Auto-calibration, Manual calibration
WBC, RBC, HGB, HCT, PLT for Calibrator calibration
- iv) Calibration Samples : Fresh normal blood samples for auto-calibration and manual calibration. SCS-1000 for Calibrator calibration

(2) Service/Production calibration

- i) Calibration Method : Manual calibration
- ii) Calibration Mode : Whole Blood Mode, Pre-diluted Mode
- iii) Calibration Parameters: WBC, RBC, HGB, HCT, PLT
- iv) Calibration Samples : SCS-1000 for Service calibration

1.6.3.13 Abnormality Detection Function

(1) Error Alerting Function

Details of this function are described in Abnormal process specifications.

The following abnormalities are monitored. An error message and alarm will occur when an abnormality is detected. An error recovery program is also provided.

- i) Hydraulic System and Mechanical System
 - a) Reagent level in the internal reservoir chambers
 - b) Fluid level in the waste chambers
 - c) Pressure and vacuum
 - d) Rinse cup operation
 - e) Others
- ii) Analysis Condition
 - a) Sampling data
 - b) HGB detection
 - c) Temperature
 - d) Clog
- iii) Electricity
 - a) Sub-processor operation
 - b) External device connection
 - c) Built-in printer connection
 - d) Built-in printer paper
- iv) Others
 - a) Calibration
 - b) Quality Control

(2) Histogram Abnormality

Monitors the abnormalities in the histograms, and adds flag to abnormal data.

- i) WL, RL, PL : Relative height at Lower Discriminator exceeds the preset limit.
- ii) WU, RU, PU : Relative height at Upper Discriminator exceeds the preset limit.
- iii) DW : The RBC histogram does not cross the 20% height level twice.
- iv) MP : Two or more peaks exist in RBC or PLT histogram.
- v) T1 : The trough discriminator cannot be set between SCR and MCR populations.
- vi) T2 : The trough discriminator cannot be set between MCR and LCR populations.
- vii) F1, F2, F3 : Relative height at the trough discriminator exceeds the preset limit.
- viii) AG : Too many cells exist at WBC Lower Level Discriminator and lower 2 channels.

(3) Analysis Results Abnormality

Monitors the abnormalities in the analysis results, and adds flag to abnormal data.

- i) abnormal value : Analysis results exceed the preset Lower or Upper level of limits.
- ii) Out of linearity range : Analysis results become beyond the linearity range

1.6.3.14 START-UP

When main power switch is turned on, the following start-up processes are automatically executed:

- (1) System Check including initialization of mechanical parts.
- (2) Auto Rinse
- (3) Background Check

The background check limit is as follows (The background check can be repeated up to three times.):

WBC : $3 \times 10^2 / \mu\text{L}$ or lower

RBC : $2 \times 10^4 / \mu\text{L}$ or lower

HGB : 0.1g/dL or lower

PLT : $1.0 \times 10^4 / \mu\text{L}$ or lower

1.6.3.15 SHUT DOWN

The hydraulic system is cleaned with diluted CELLCLEAN aspirated from the whole blood pipette. To shut down the system, press the [Shutdown] key.

1.6.3.16 Service Maintenance

The details of special sequence for services and test process are defined in Service Maintenance Specification manual.

- (1) Customer Maintenance
 - i) Detector Rinse sequence with clog removal process
 - ii) Auto rinse with background check sequence
 - iii) Waste Chamber Cleaning sequence
 - iv) Shutdown
 - v) Parameter change/Print
 - vi) Transducer drain
 - vii) Reagent Replacement Sequence
 - viii) Built-in Printer paper feeding

- ix) Status Display
 - HGB convert value (Realtime display)
 - Pressure value (Realtime display)
 - Instrument and unit operation cycle count
 - * Temperature and sampling data is displayed on Service data view.

(2) Service Sequences (Service purpose only)

- i) Instrument installation sequence
- ii) Service data Printing
- iii) Gain adjustment
- iv) Initialize/Change/Print setting values
- v) Stop sequence
- vi) Initialize all settings
- vii) Shipment sequence
- viii) Continuous mode
- ix) Control blood analysis mode
- x) Clog removal

(3) Test Processing (Service purpose only)

- i) Diaphragm test operation
- ii) Solenoid valve operation
- iii) Compressor operation
- iv) Built-in Printer output test

(4) Service Information Display/Print (Service Purpose Only)

- i) Temperature
- ii) Operation status
- iii) Sampling data
- iv) Service data

(5) Program supply

- i) Version up program by Compact Flash

1.6.3.17 Safety Protection

(1) Main Unit Power Supply: Fuse

1.6.3.18 Reagent Control (exclude XP-100 for China market)

Scan the unique barcode on the reagent container so that the following data can be read by barcode reader on reagent replacement.

- (1) Reagent Name
- (2) Replacement Date/Time
- (3) Lot Number
- (4) Serial Number
- (5) Expiration Date of reagent
- (6) Expiration date of reagent after opening
- (7) Products Code *In case of genuine products, the field is null.
- (8) Manufacturer(Seller) *In case of genuine products, the field is null
- (9) Manufacturer(Seller) *In case of genuine products, the field is null

1.7 TRACEABILITY

Items	Traceability guaranty	Calibration standard material	Reason for null
WBC	ICSH Reference method	SCS - 1000	-
RBC	ICSH Reference method	SCS - 1000	-
HGB	ICSH Reference method	SCS - 1000	-
HCT	ICSH Reference method	SCS - 1000	-
MCV MCH MCHC	-	-	Due to calculated item.
PLT	ICSH Reference method	SCS - 1000	-
W-SCR W-MCR W-LCR W-SCC W-MCC W-LCC RDW-CV RDW-SD PDW MPV P-LCR PCT	-	-	Due to analyzed and calculated items from histogram of WBC, RBC and PLT

1.8 REQUIREMENTS

1.8.1 Environmental Requirements

- (1) Ambient temperature : 15 - 30°C(The reagent temperature should also be within this range.)
- (2) Relative Humidity : 30 - 85%
- (3) Atmospheric Pressure : 70 - 106kPa
- (4) Installation Condition : Avoid installation in a place where the instrument may be exposed to direct sunlight, dust, vibration or acid
- (5) Electromagnetic Environment
EMC conformity standard : IEC61326-2-6: 2005
EMI(emission) test : Class A

1.8.2 Electric Source

- (1) Voltage : 100, 120, 220, 230, 240V/AC
- (2) Frequency : 50/60Hz

1.8.3 Reagents

- (1) Diluent : CELLPACK
- (2) Lyse reagent : STROMATOLYSER-WH
- (3) Detergent : CELLCLEAN

1.9 OPERATION AND MAINTENANCE

1.9.1 Operation

- (1) Applicable Sample Collection Tube
Length : 80 mm or shorter (Excluding lid)
- (2) Preparation
 - i) Reagent check and replacement
Check the volume of reagent and replace when needed.
 - ii) Turn on power
 - iii) Check instruments
Instruments starts self-check process automatically, when power is turned on.
 - iv) Quality Control
Check data with control blood or other QC method.
- (3) Measurement
Press [Start] switch to aspirate sample with pipette and measure.
- (4) Analysis results
Analysis results is displayed after measurement. The result can be printed and output to a computer.
- (5) Post-analysis operation
 - i) Cleaning is executed automatically during shutdown process.
 - ii) Turn off the instrument
- (6) Preventive Maintenance
To keep reliability of analysis results, carry out PM by control blood and other method, and to keep the instruments stable, carry out defined maintenance items periodically.

1.9.2 Supply

- (1) Reagent
Diluent, Lyse reagent, CELLCLEAN
- (2) Consumables
 - i) Replacement parts : Fuse
 - ii) Filling parts : Paper for printing
 - iii) Additional parts : Brush, Pipette

1.9.3 Maintenance

(1) Customer Maintenance

Customer maintenance and service should be executed from the front or side faces.

- i) Shutdown : Once/day
- ii) Clean SRV : Once/3 months or when operation cycle count becomes 4,500 cycles
- iii) Clean detector : Once/Month or when operation cycle count becomes 1,500 cycles
- iv) Clean waste chamber: Once/Month or when operation cycle count becomes 1,500 cycles
- v) Replace reagent : As needed

(2) User Maintenance Item

User maintenance should be executed from the front or side.

- i) Clean detector
- ii) Pressure adjustment

(3) Regular Maintenance Item by FSR

None

1.10 PACKAGING

Package Unit	Dimension(mm)	Total Weight	Weight of packages	Corrugated board
Main body and accessories	505Dx595Wx593H	Approx. 35kg	Approx. 4.4kg	NO

1.11 ATTACHMENTS

1.11.1 Accessories

- (1) Service Manual
- (2) Power cord
- (3) Dispensing set
- (4) Tray
- (5) Tubes
- (6) Syringe
- (7) Brush
- (8) Fuse
- (9) Clamp
- (10) Paper for printing (Roll sheet)

1.12 REQUIRED CONDITIONS

1.12.1 Environmental Conditions

- (1) Ambient Temperature : 15 - 30°C
 - (2) Relative Humidity : 30 - 85%, No dew condensation
 - (3) Atmospheric Pressure : 70 - 106kPa
- Avoid an installation location where the instrument may be exposed to direct sunlight.

1.13 ACOUSTIC NOISE

The noise level should be 55dB or less in conformity with SYSMEX internal testing method.

1.14 EXPECTED LIFE TIME

- (1) Service life : 5 years
- (2) Number of standard sample processing : 60 samples/day
- (3) Designed life time : 60 samples/day x 300 days/year x 5 years = 90,000 samples

CHAPTER 2 HYDRAULICS AND MECHANICAL SYSTEM

2.1 HYDRAULIC SYSTEM BLOCK DIAGRAM	1
2.1.1 Block Diagram (Whole Blood Mode)	1
2.1.2 Block Diagram (Pre-diluted Mode)	1
2.2 ANALYSIS FLOW	2
2.2.1 WBC/HGB Analysis Flow	2
2.2.2 RBC/PLT Analysis Flow	2
2.3 SAMPLE FLOW IN SRV	3
2.3.1 Sample Path	3
2.3.2 Sample Path (Whole Blood Mode)	4
2.3.3 Sample Path (Pre-diluted Mode)	4
2.4 SOLENOID VALVE LOCATION	5
2.5 DIAPHRAGM PUMP LOCATION	6
2.6 MASTER VALVE LOCATION	7
2.6.1 Valve Unit A	7
2.6.2 Valve Unit B	8
2.7 PNEUMATIC SYSTEM	9
2.7.1 Sample Aspiration System	9
2.7.2 Vacuum System	10
2.7.3 Pressure System	10
2.8 WASTE CHAMBER TUBING	11
2.9 RINSE CUP	11
2.10 RBC DETECTOR UNIT	12
2.11 WBC DETECTOR UNIT	12
2.12 SRV UNIT	13
2.13 HYDRAULIC FLOW DESCRIPTION	14
2.13.1 Whole Blood Mode	14
2.13.1.1) Sample Aspiration	14
2.13.1.2) HGB Blank Analysis	15
2.13.1.3) Creating samples for RBC and WBC analysis	16
2.13.1.4) HGB Analysis	19
2.13.1.5) RBC/WBC analysis	20
2.13.2 Pre-diluted Mode	21
2.13.2.1) Sample Aspiration	21
2.13.2.2) HGB blank analysis	21
2.13.2.3) Preparing samples for RBC/WBC analysis	22
2.13.2.4) HGB Analysis	22
2.13.2.5) RBC/WBC Analysis	22
2.14 PNEUMATIC & HYDRAULIC PARTS	23

CHAPTER 2 HYDRAULICS AND MECHANICAL SYSTEM

2.1 HYDRAULIC SYSTEM BLOCK DIAGRAM

2.1.1 Block Diagram (Whole Blood Mode)

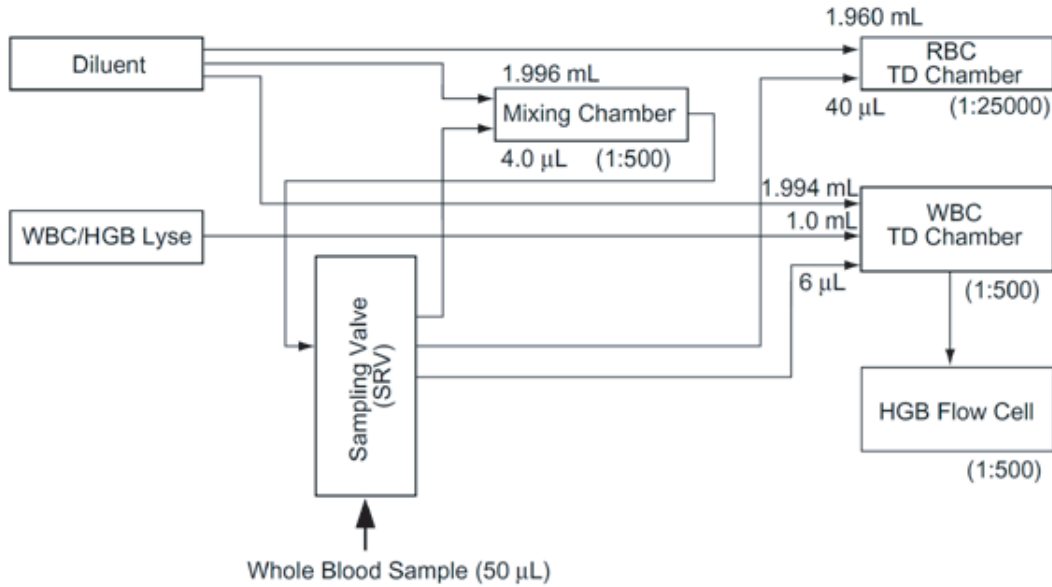

Figure 2-1-1: Whole Blood Mode Block Diagram

2.1.2 Block Diagram (Pre-diluted Mode)

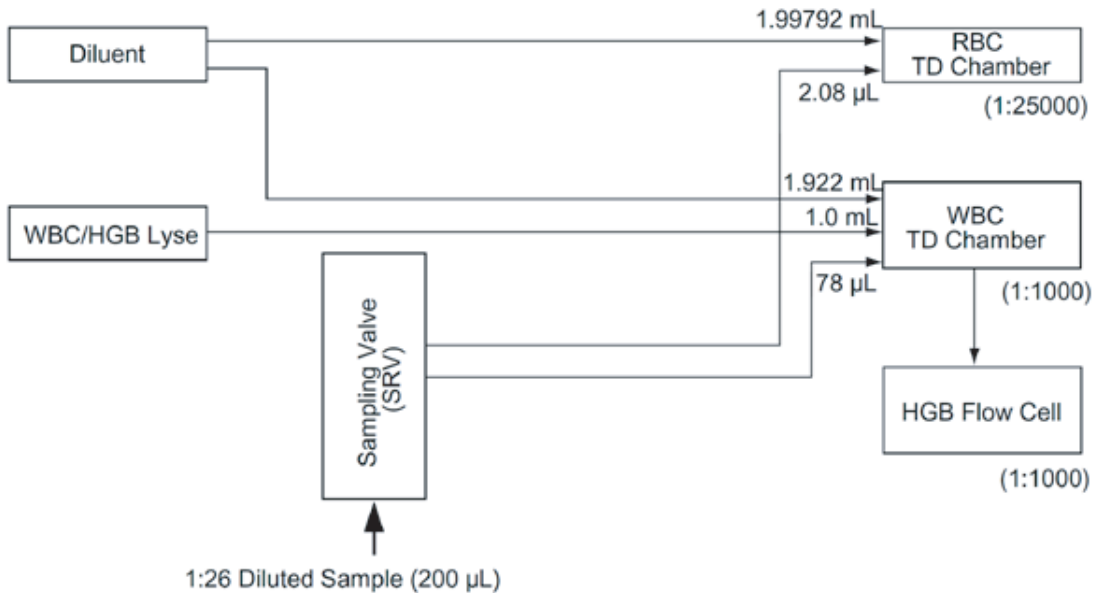

Figure 2-1-2: Pre-diluted Mode Block Diagram

2.2 ANALYSIS FLOW

2.2.1 WBC/HGB Analysis Flow

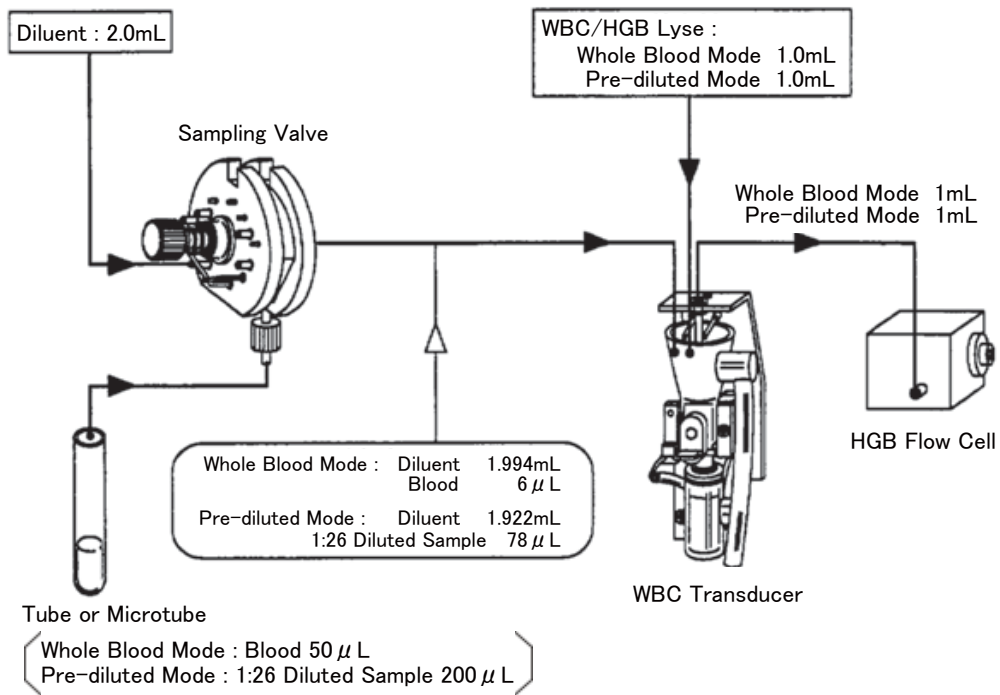

Figure 2-2-1: WBC/HGB Analysis Flow

2.2.2 RBC/PLT Analysis Flow

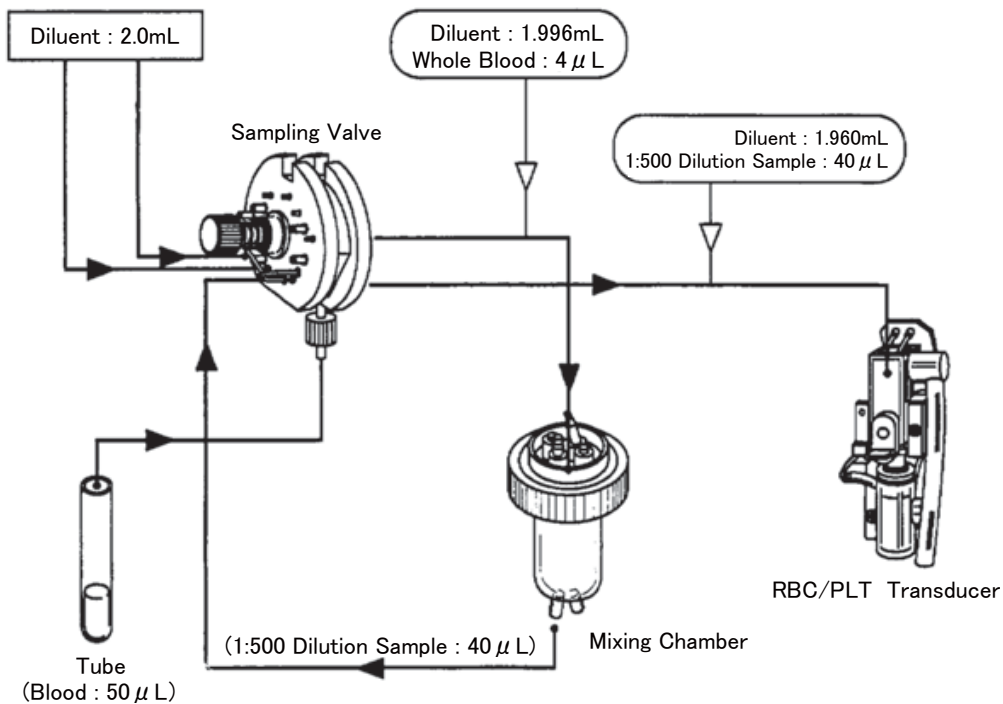

Figure 2-2-2: RBC/PLT Analysis Flow (Whole Blood Mode)

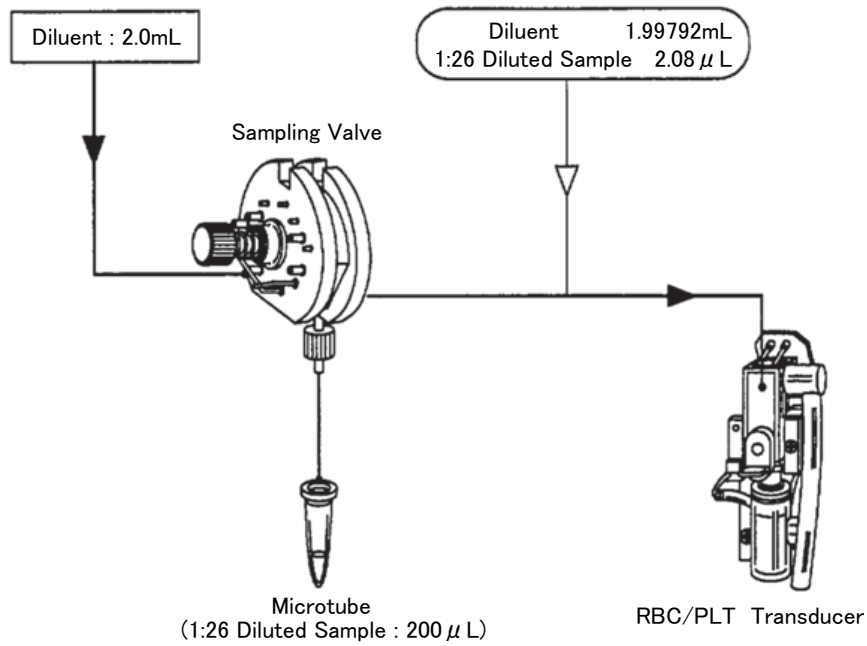

Figure 2-2-3: RBC/PLT Analysis Flow (Pre-diluted Mode)

2.3 SAMPLE FLOW IN SRV

2.3.1 Sample Path

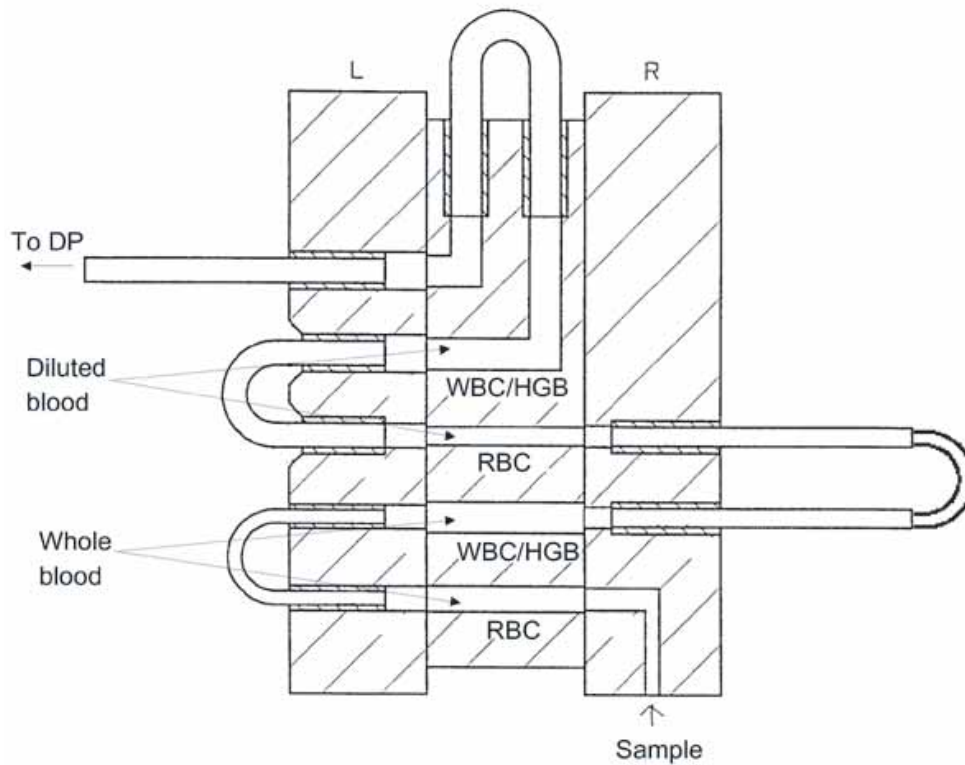

Figure 2-3-1: Sample Flow in SRV

2.3.2 Sample Path (Whole Blood Mode)

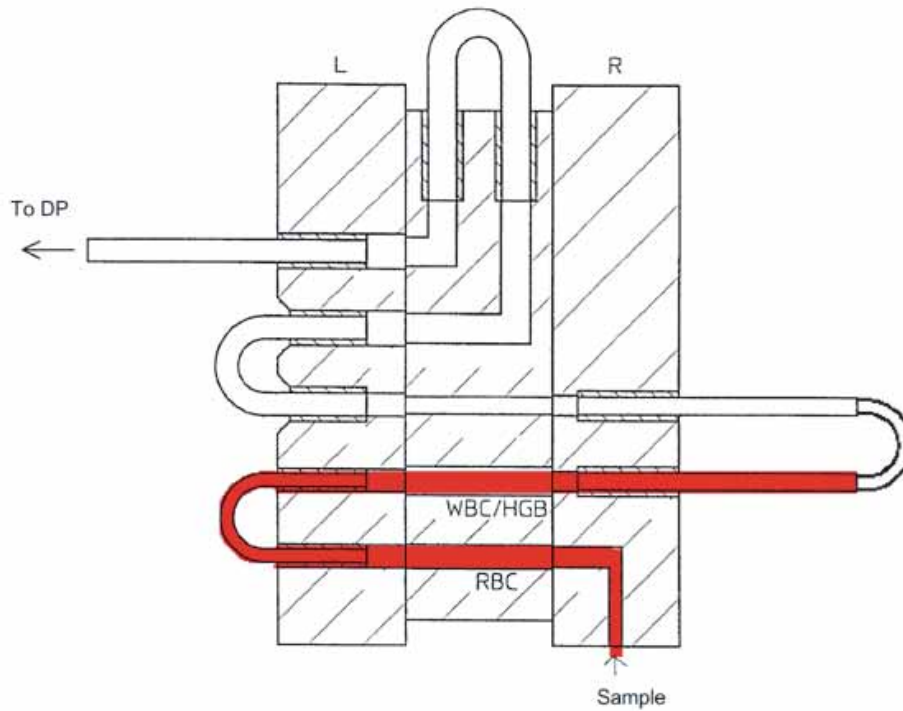

Figure 2-3-2: Sample Flow in SRV (Whole Blood Mode)

2.3.3 Sample Path (Pre-diluted Mode)

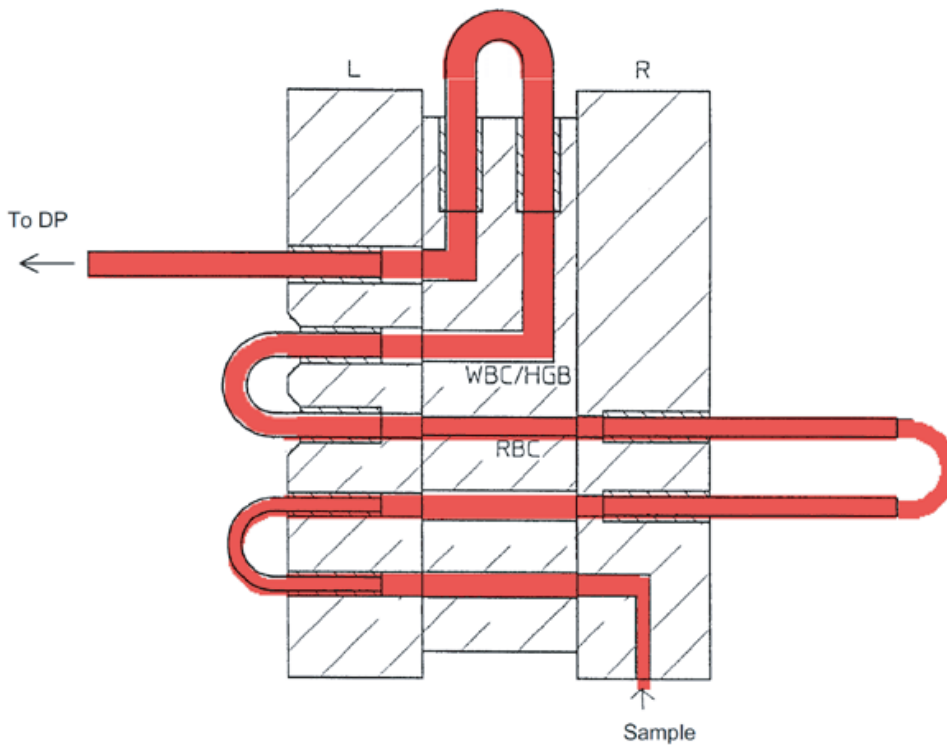

Figure 2-3-3: Sample Flow in SRV (Pre-diluted Mode)

2.4 SOLENOID VALVE LOCATION

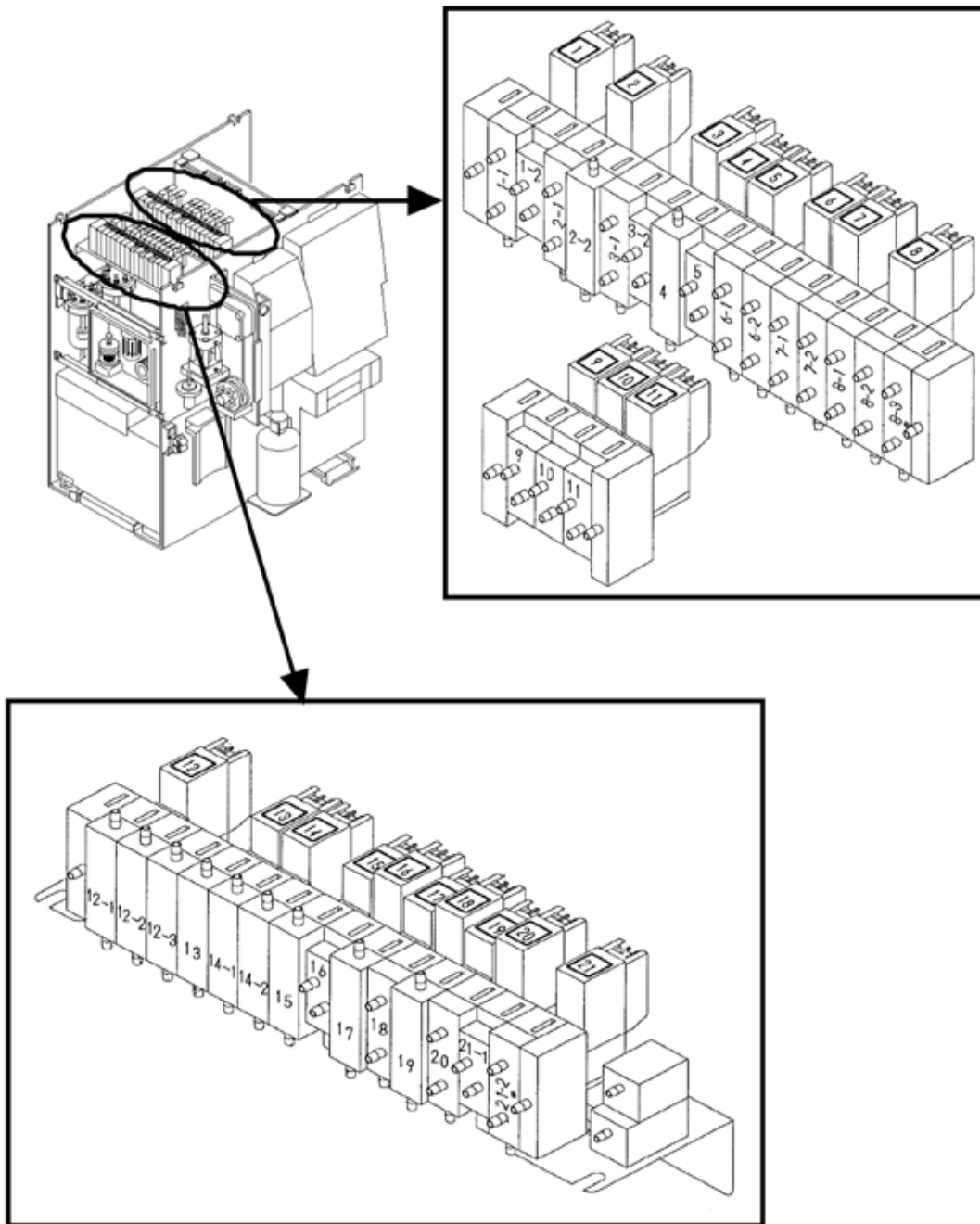

Figure 2-4-1: Valve Location

2.5 DIAPHRAGM PUMP LOCATION

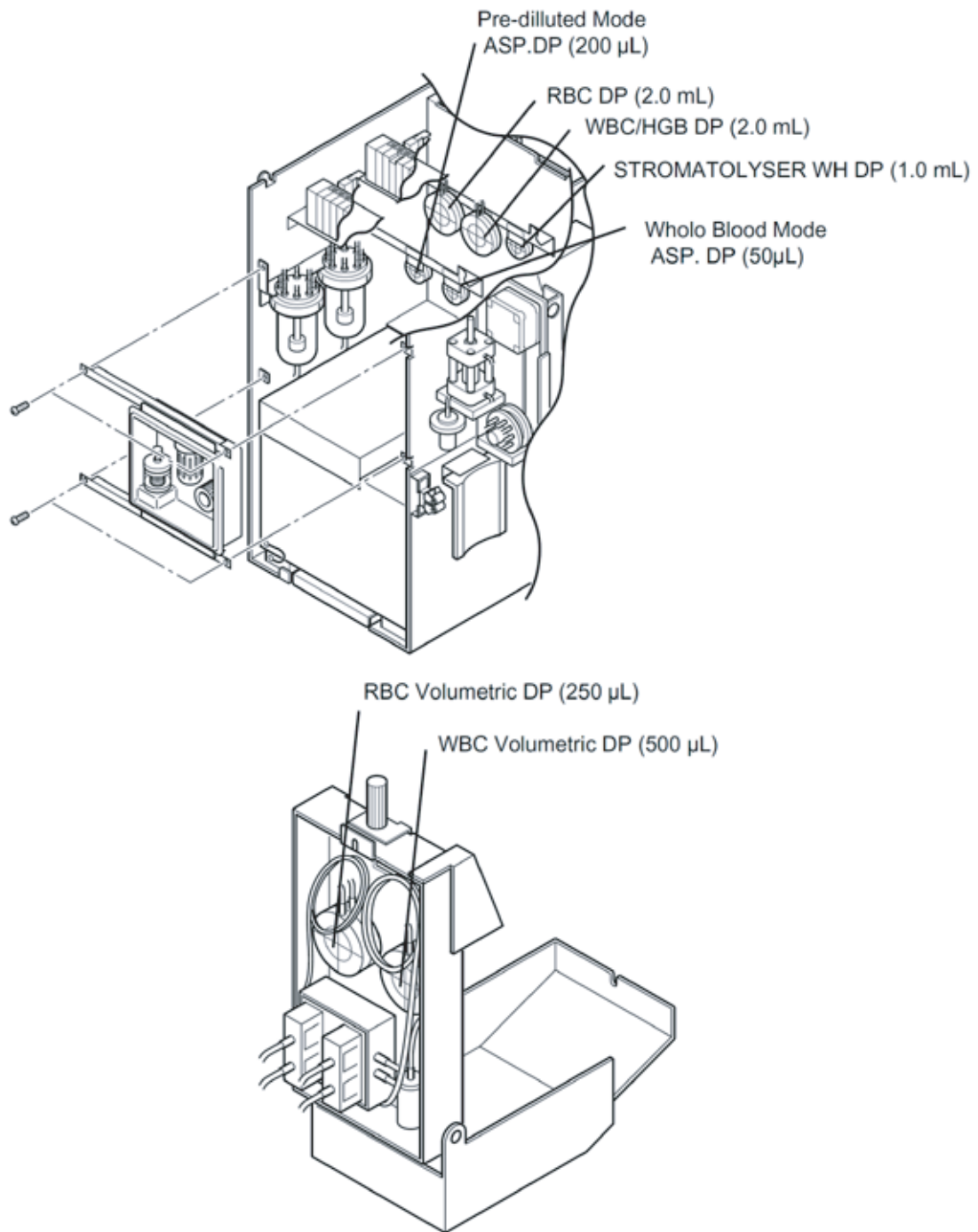

Figure 2-5-1: Diaphragm Pump Location

2.6 MASTER VALVE LOCATION

2.6.1 Valve Unit A

MV No.	Function	MV No.	Function
1-1	Waste drain, switch pressure/vacuum	6-1	RBC diluent DP fill/dispense switch
1-2	Waste drain, drive Pinch Valve	6-2	RBC diluent DP drive
2-1	Diluent fill, switch pressure/vacuum	7-1	RBC diluent line switch
2-2	Diluent fill, connect diluent line	7-2	WBC/Hgb diluent line switch
3-1	Diluent chamber pressure relief	8-1	WBC/Hgb diluent DP/lyse DP drive
3-2	Rinse cup drain, drive Pinch Valve	8-2	WBC/Hgb diluent DP switch
4	STR-WH (lyse) dispense control	8-3	WBC/Hgb lyse DP switch
5	Fill Detector Block Master Valve Assy		

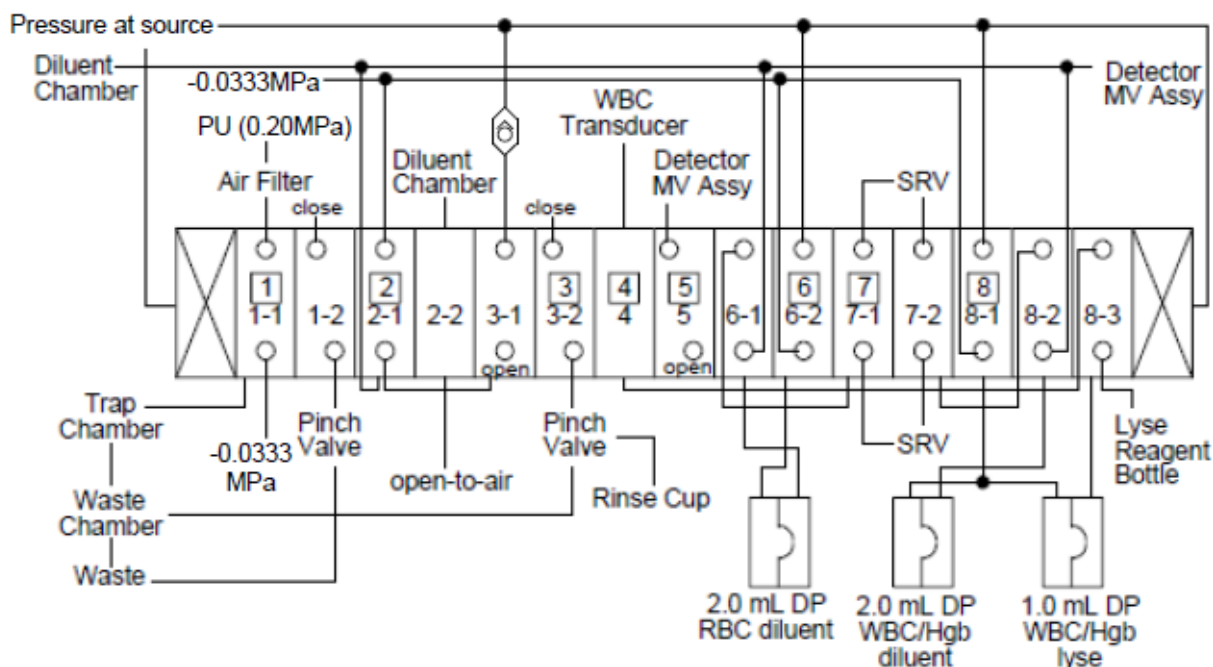

Figure 2-6-1: Valve Unit A-1 Tubing A

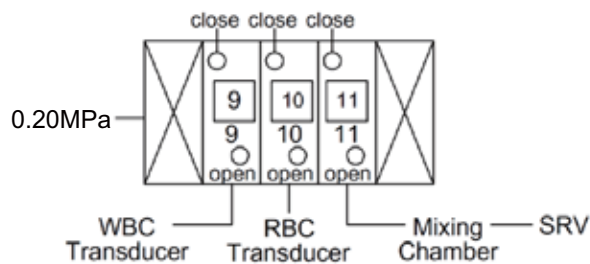

Figure 2-6-2: Valve Unit A-2 Tubing

A 201297

2.6.2 Valve Unit B

MV No.	Function	MV No.	Function
12-1	Fill Rinse Cup	16	SRV rotation
12-2	SRV vacuum cut	17	RBC charging
12-3	SRV outer rinse	18	PD mode sample aspiration DP drive
13	Mixing Chamber drain	19	Supply rinse into sample aspiration line
14-1	RBC Transducer drain	20	WB mode sample aspiration DP drive
14-2	WBC Transducer drain	21-1	Air gap generation
15	Hgb Flow Cell drain	21-2	Detector DP drive for counting

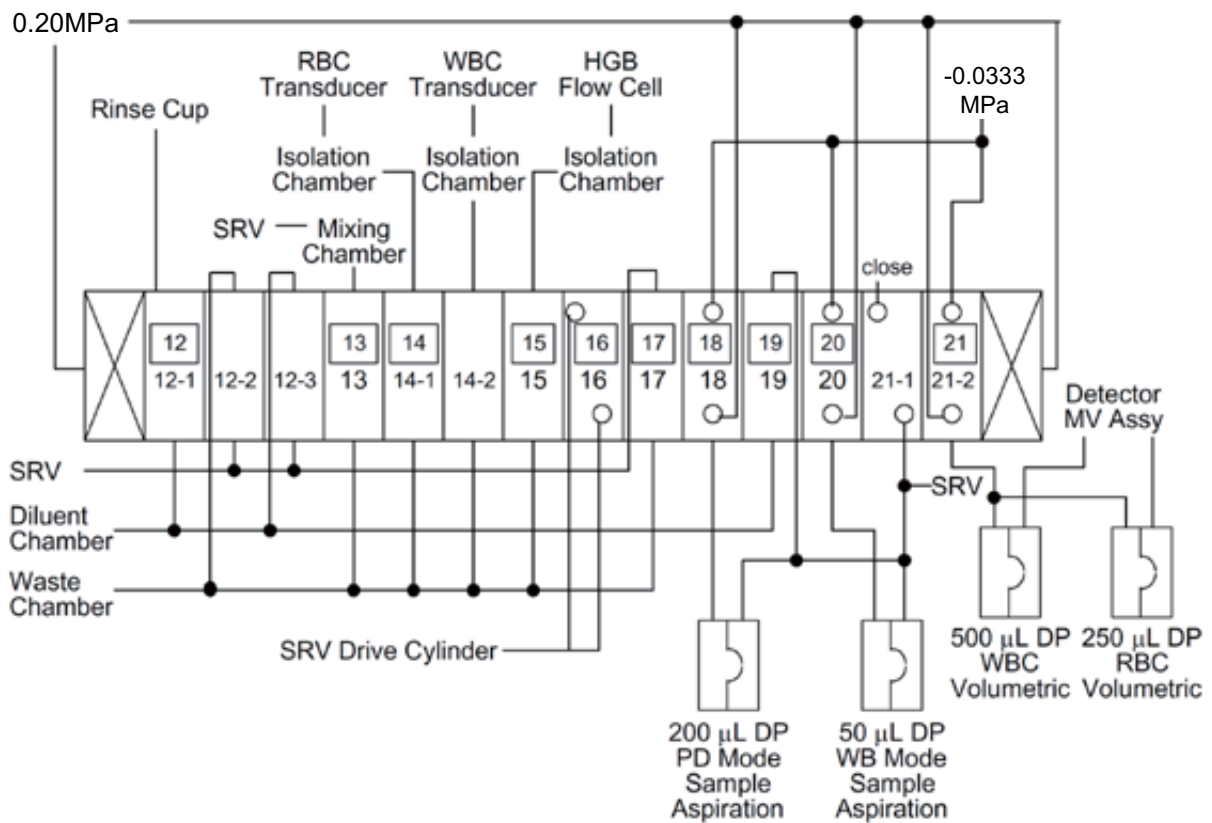

Figure 2-6-3: Valve Unit B Tubing

2.7 PNEUMATIC SYSTEM

Pressure is only monitored for 0.05MPa. (Pressure at the source is not monitored.) A

Vacuum is only monitored for -0.0333MPa. (Vacuum source is not monitored.)

2.7.1 Sample Aspiration System

Aspiration speed is adjusted to Whole Blood mode. Tube Teflon is inserted between Whole Blood DP and Diluted Blood DP for adjusting aspiration speed.

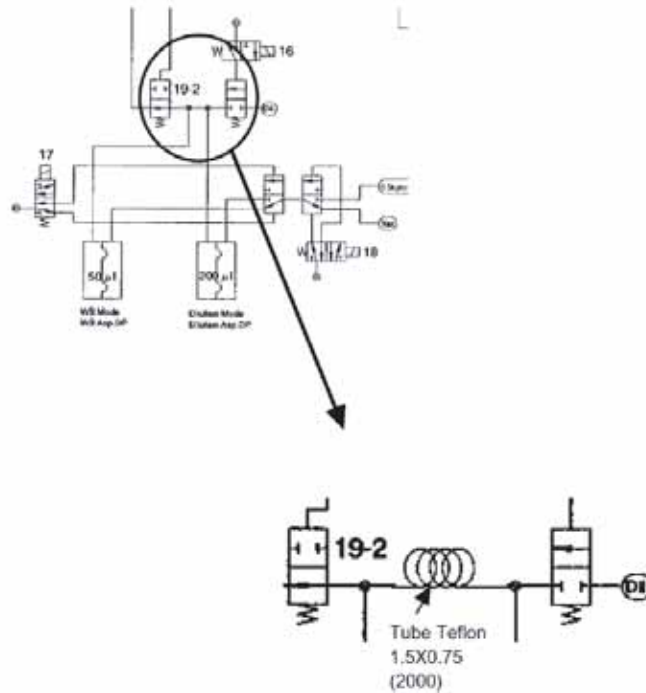

Figure 2-7-1: Sample Aspiration System

A 201297

2.7.2 Vacuum System

XP series has no tank for Vacuum system therefore Polyurethane tubing is inserted between bellows and pressure switch for stabilizing the vacuum.

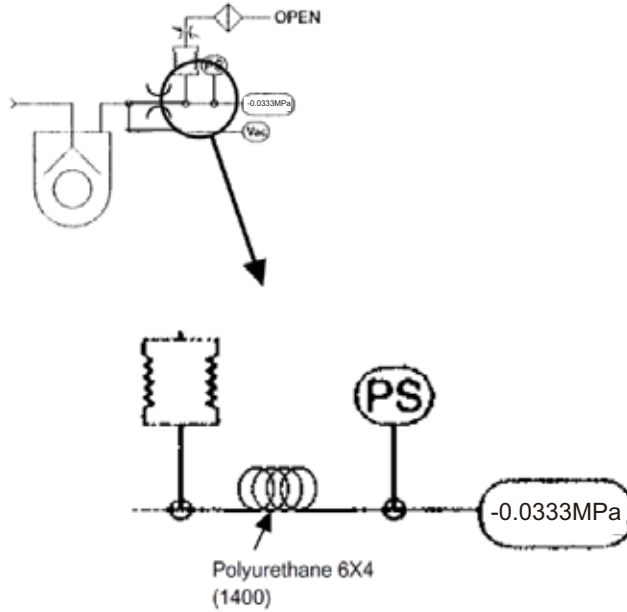

Figure 2-7-2: Vacuum System

2.7.3 Pressure System

XP series has no tank for pressure system therefore Teflon tubing is inserted between compressor and 0.05MPa regulator for stabilizing the pressure.

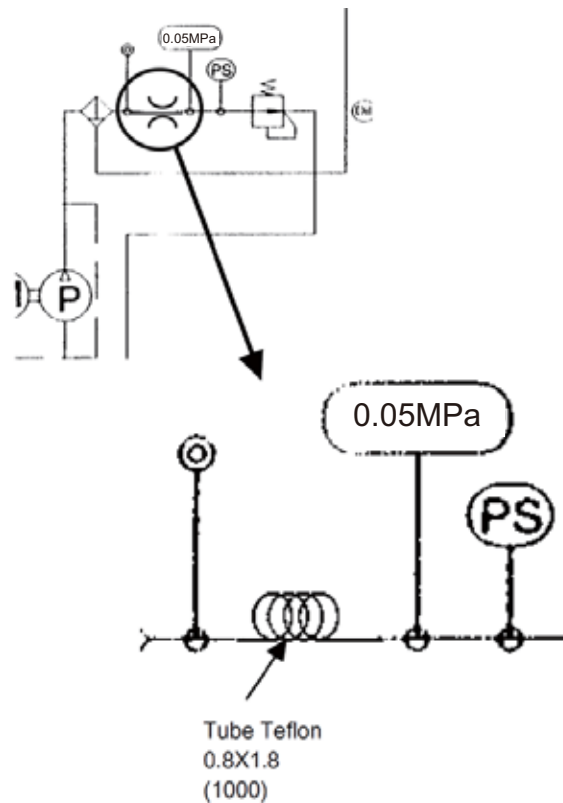

Figure 2-7-3: Pressure System

2.8 WASTE CHAMBER TUBING

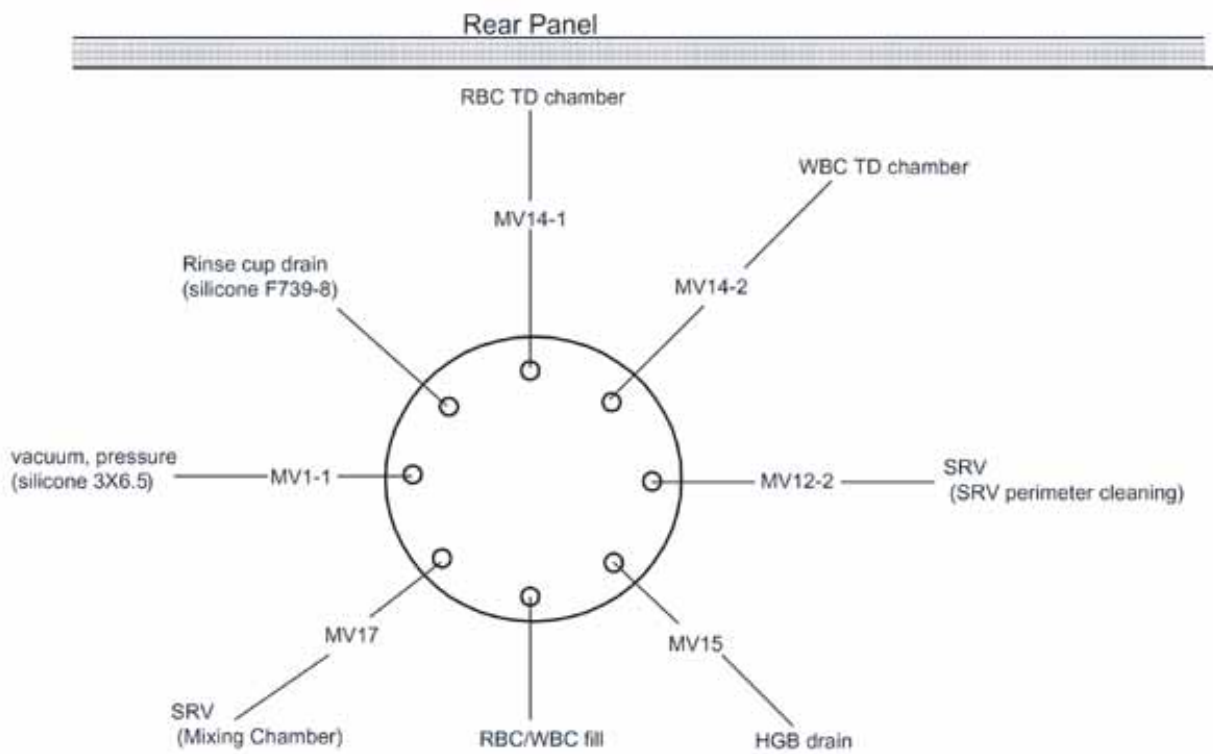

Figure 2-8-1: Waste Chamber Tubing

2.9 RINSE CUP

Rinsing solution is injected while the rinse cup is going down and any blood adhering to the pipette exterior is aspirated into the waste chamber. (Left in Figure 2-9-1 below.)

To clean the whole blood line, rinsing solution (containing whole blood) is discharged from the pipette tip and aspirated into the waste chamber when the rinse cup reaches the lower end point. When the rinse cup goes up, rinsing solution will not be discharged nor aspirated into the pipette. (Right in Figure 2-9-1 below.)

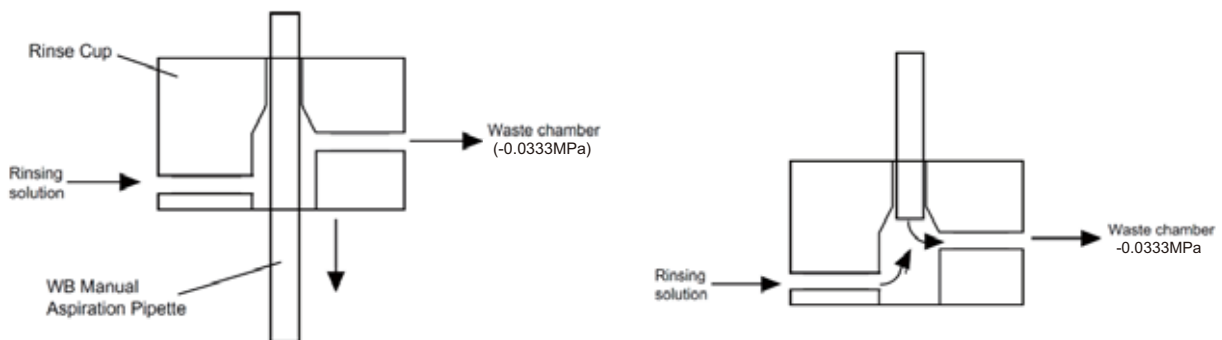

Figure 2-9-1: Rinse Cup

2.10 RBC DETECTOR UNIT

Aperture size: 75 μm

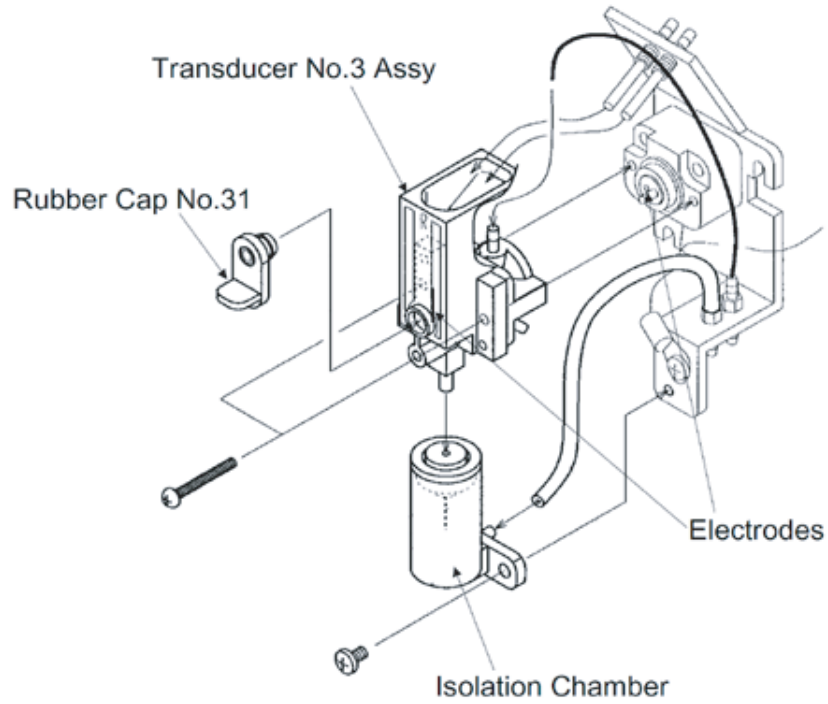

Figure 2-10-1: RBC Detector Unit

2.11 WBC DETECTOR UNIT

Aperture size: 100 μm

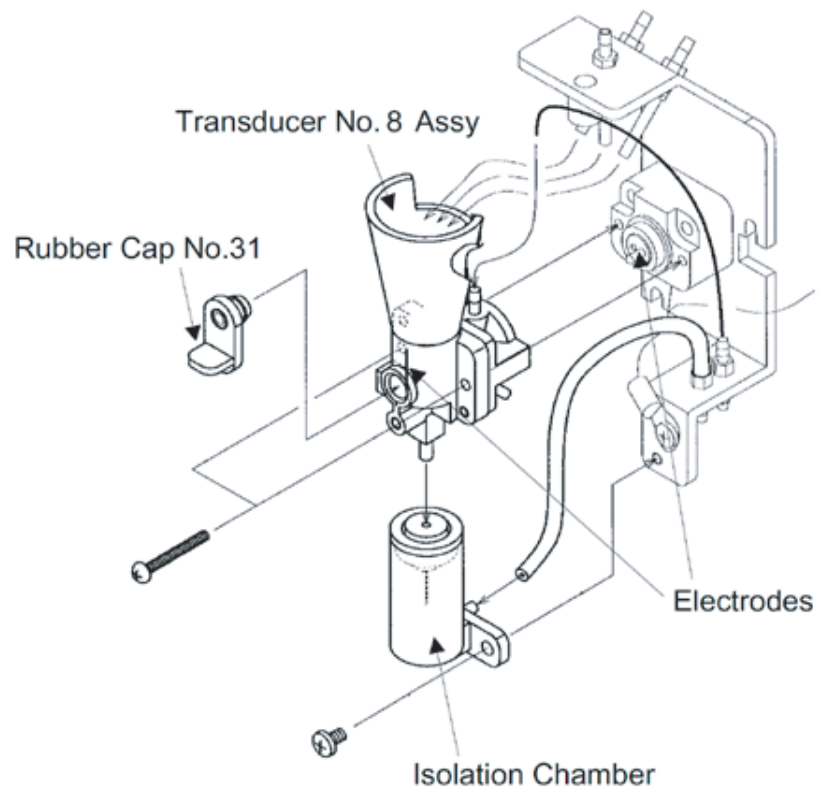

Figure 2-11-1: WBC Detector Unit

2.12 SRV UNIT

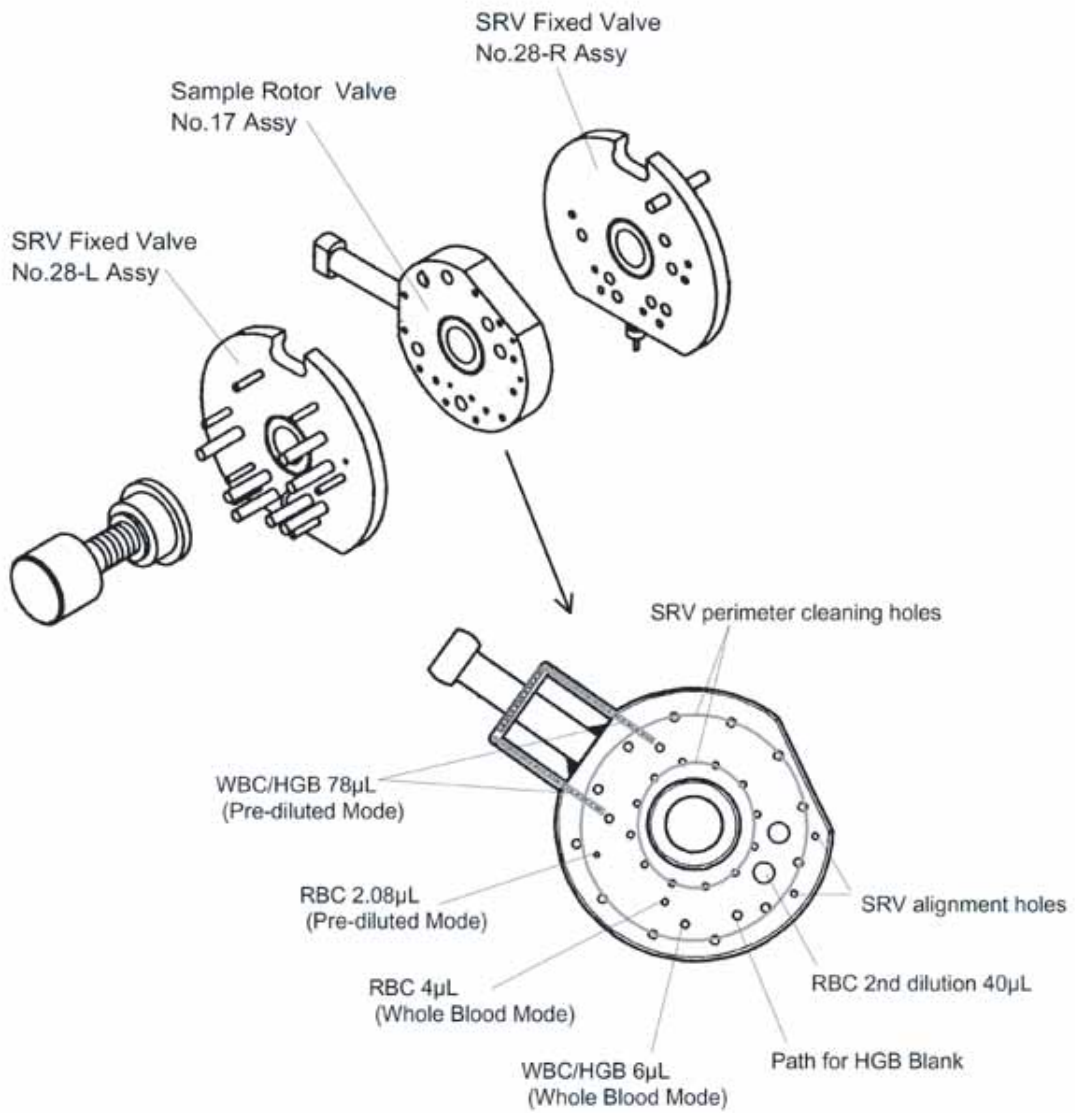

Figure 2-12-1: SRV Unit

2.13 HYDRAULIC FLOW DESCRIPTION

2.13.1 Whole Blood Mode

2.13.1.1) Sample Aspiration

1) Samples are aspirated into SRV using Whole Blood Mode Aspiration Diaphragm Pump.

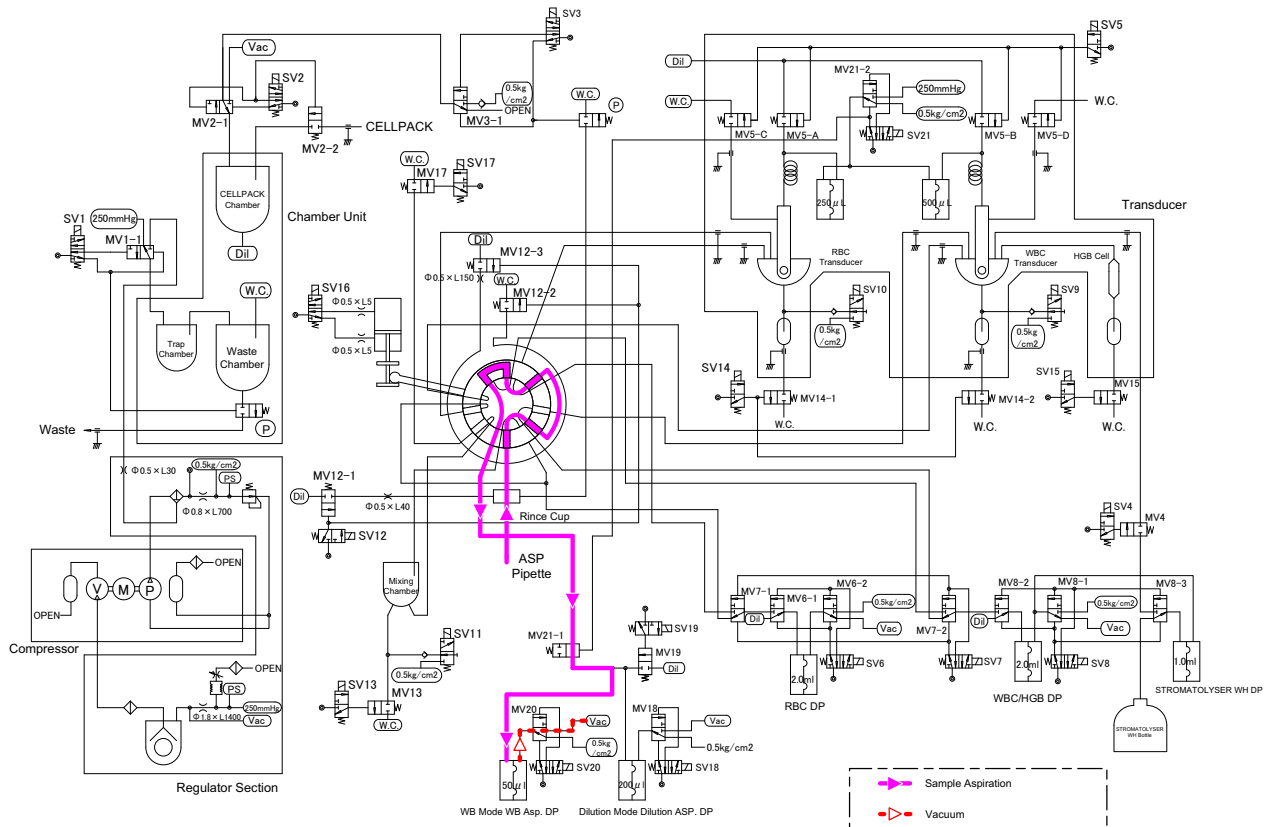

2.13.1.2) HGB Blank Analysis

- 1) Samples (diluent and lyse) in WBC Detector Unit are aspirated into HGB Flow Cell to perform HGB blank analysis.

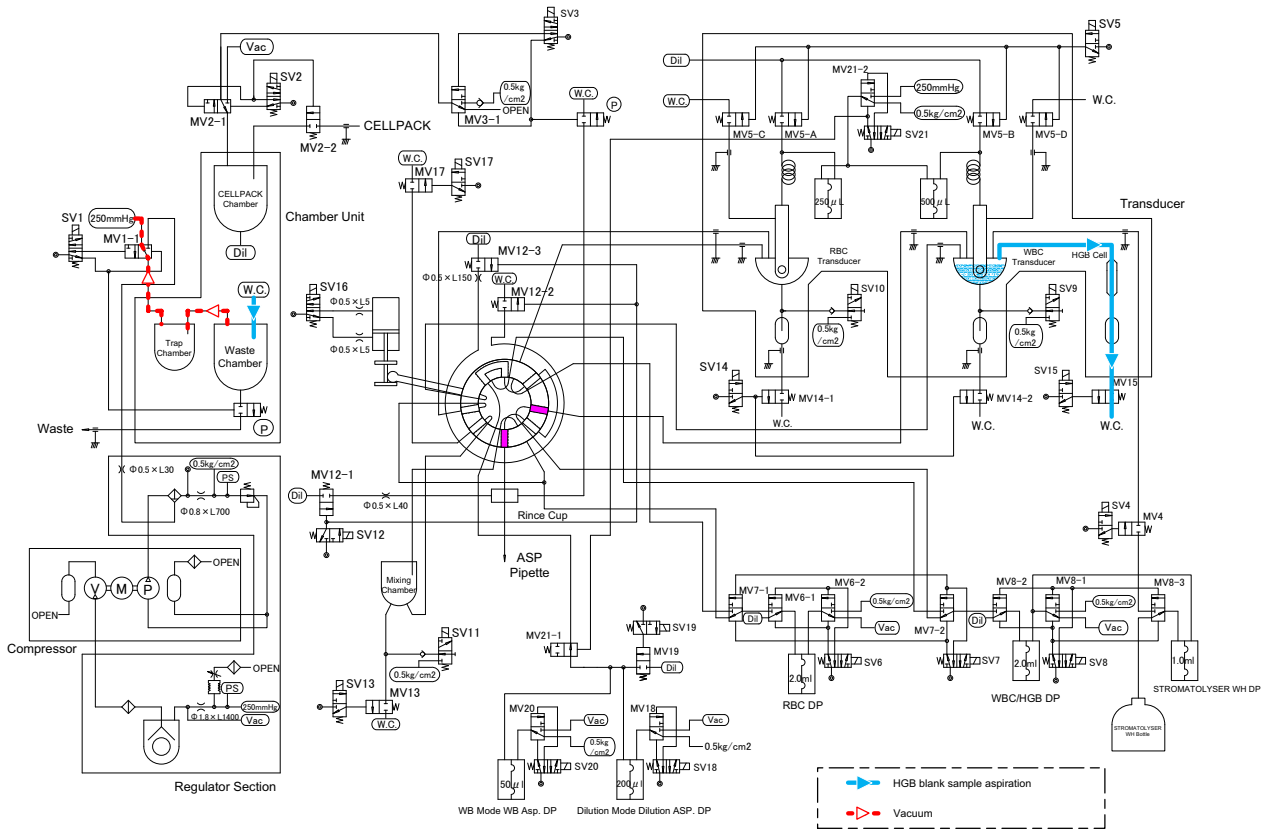

2.13.1.3) Creating samples for RBC and WBC analysis

- 1) SRV rotates.
- 2) Samples within SRV and diluent are dispensed into Mixing Chamber to create RBC 1st dilution samples.
- 3) RBC 1st dilution samples are mixed in Mixing Chamber by bubbles.

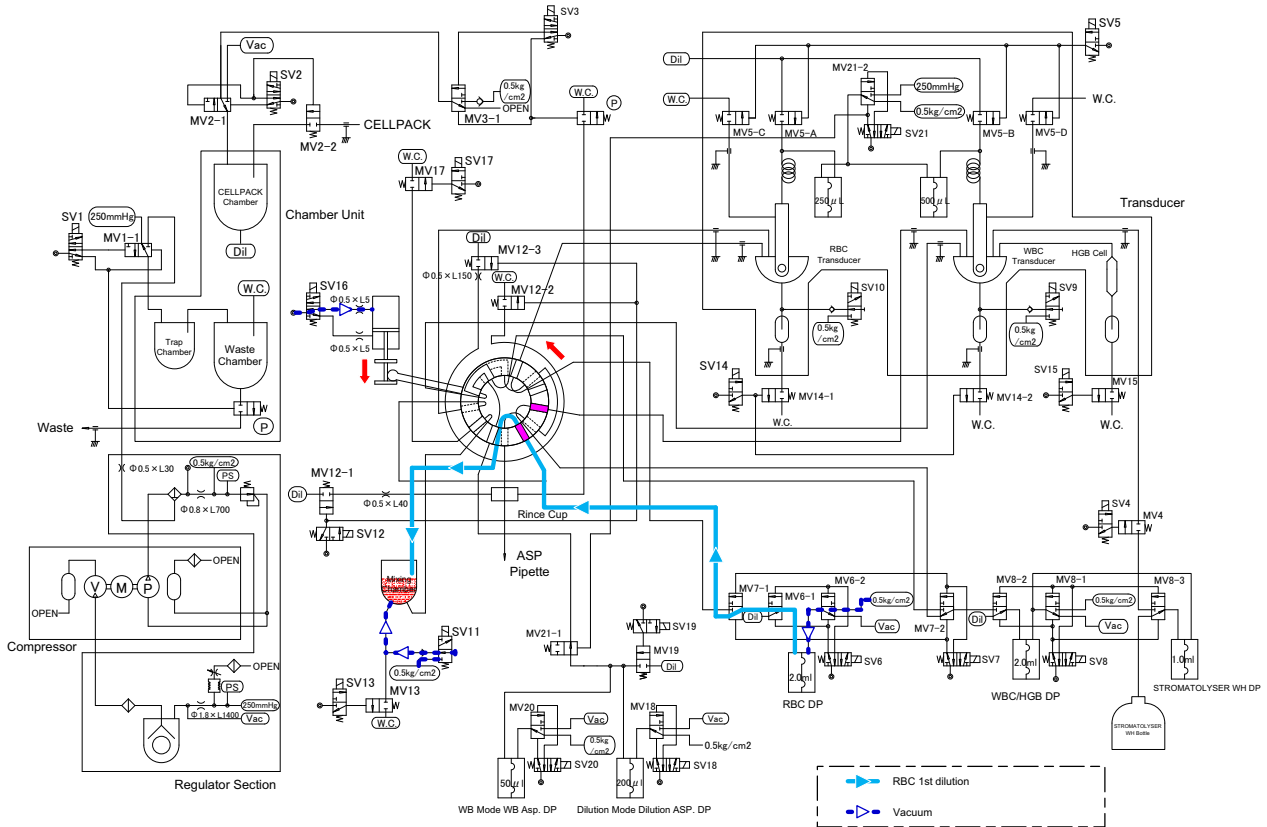

4) RBC 1st dilution samples are within SRV.

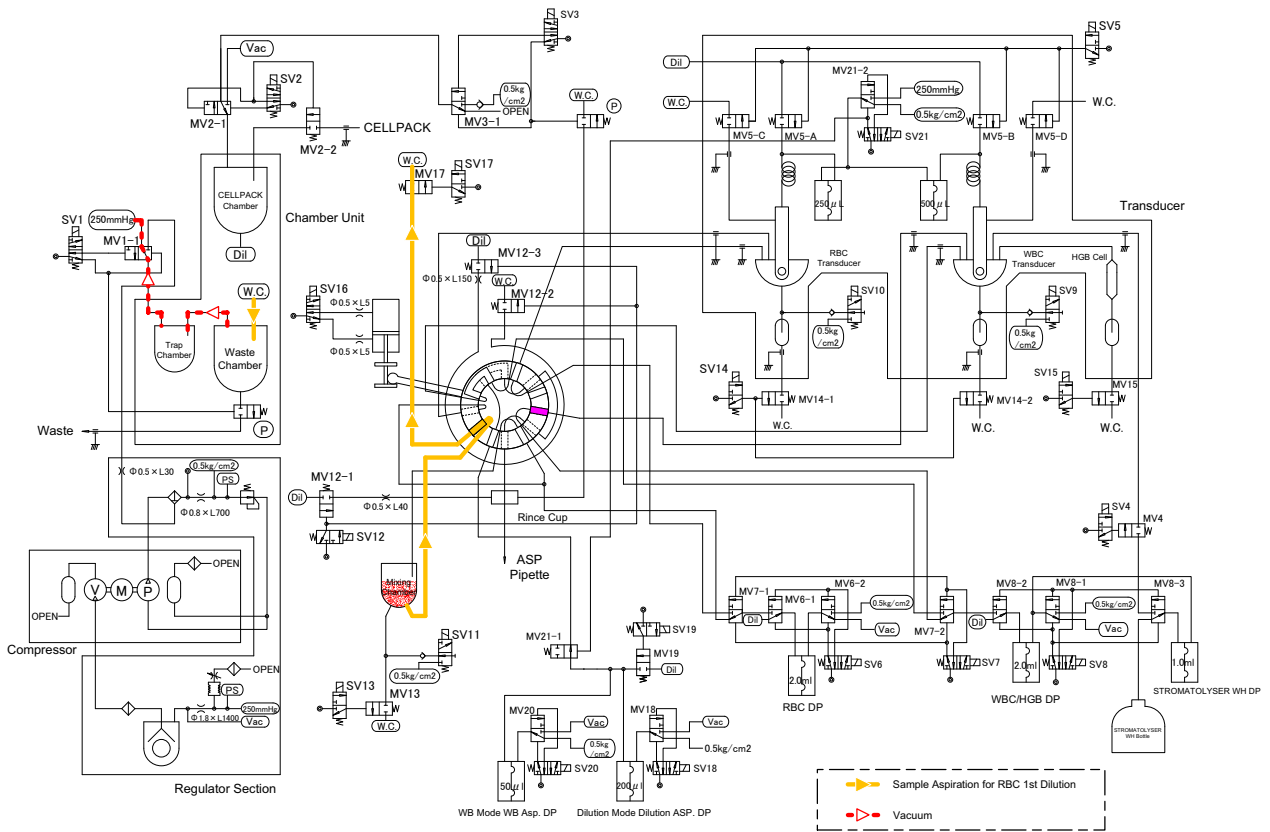

- 5) SRV rotates.
- 6) RBC 1st dilution samples within SRV and diluent are dispensed into RBC Detector Unit to create samples for RBC analysis.
- 7) Samples within SRV, diluent and lyse are dispensed into WBC Detector Unit to create samples for WBC/HGB analysis.
- 8) Samples for RBC/WBC analysis are mixed by bubbles in the applicable detector units.

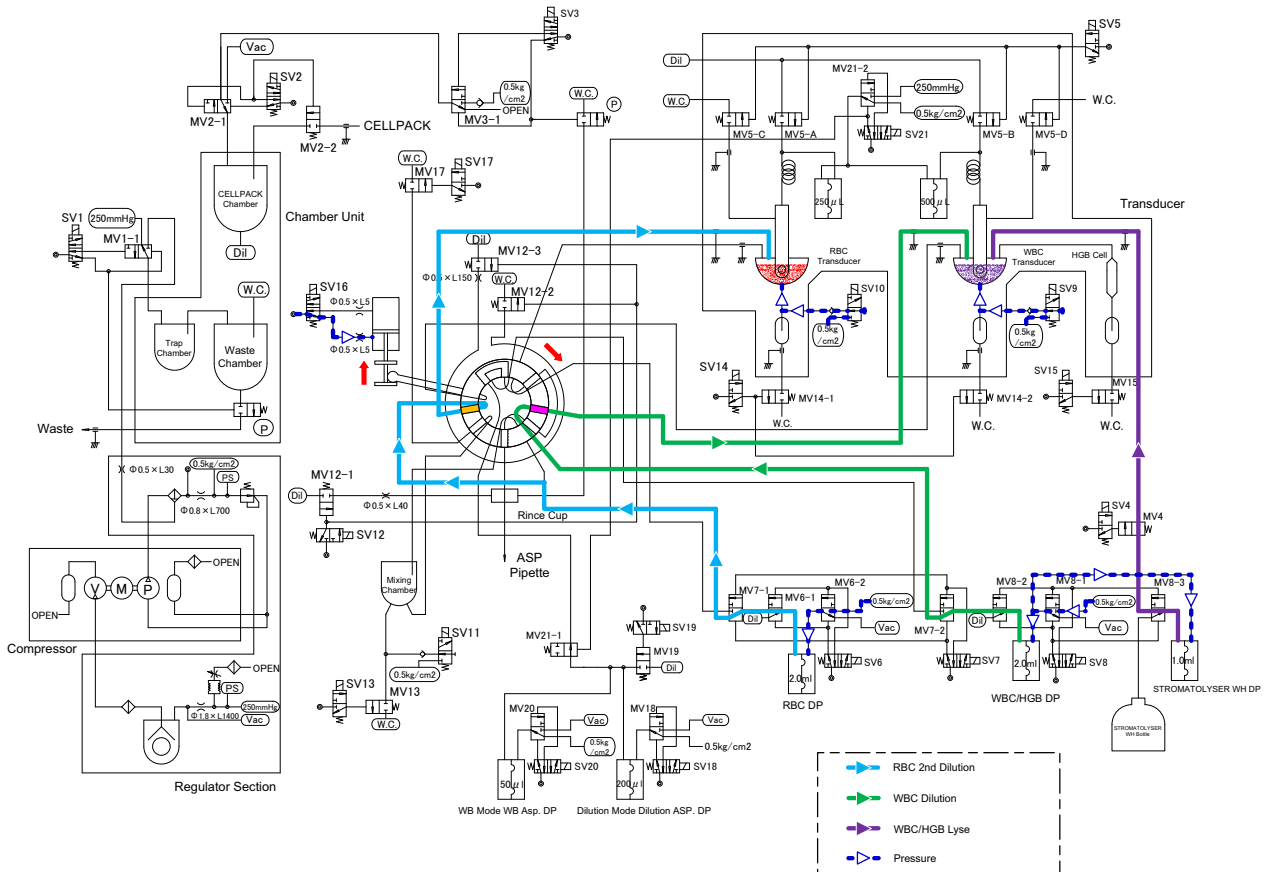

2.13.1.4) HGB Analysis

- 1) Samples in WBC Detector Unit are aspirated into HGB Flow Cell to perform HGB analysis.

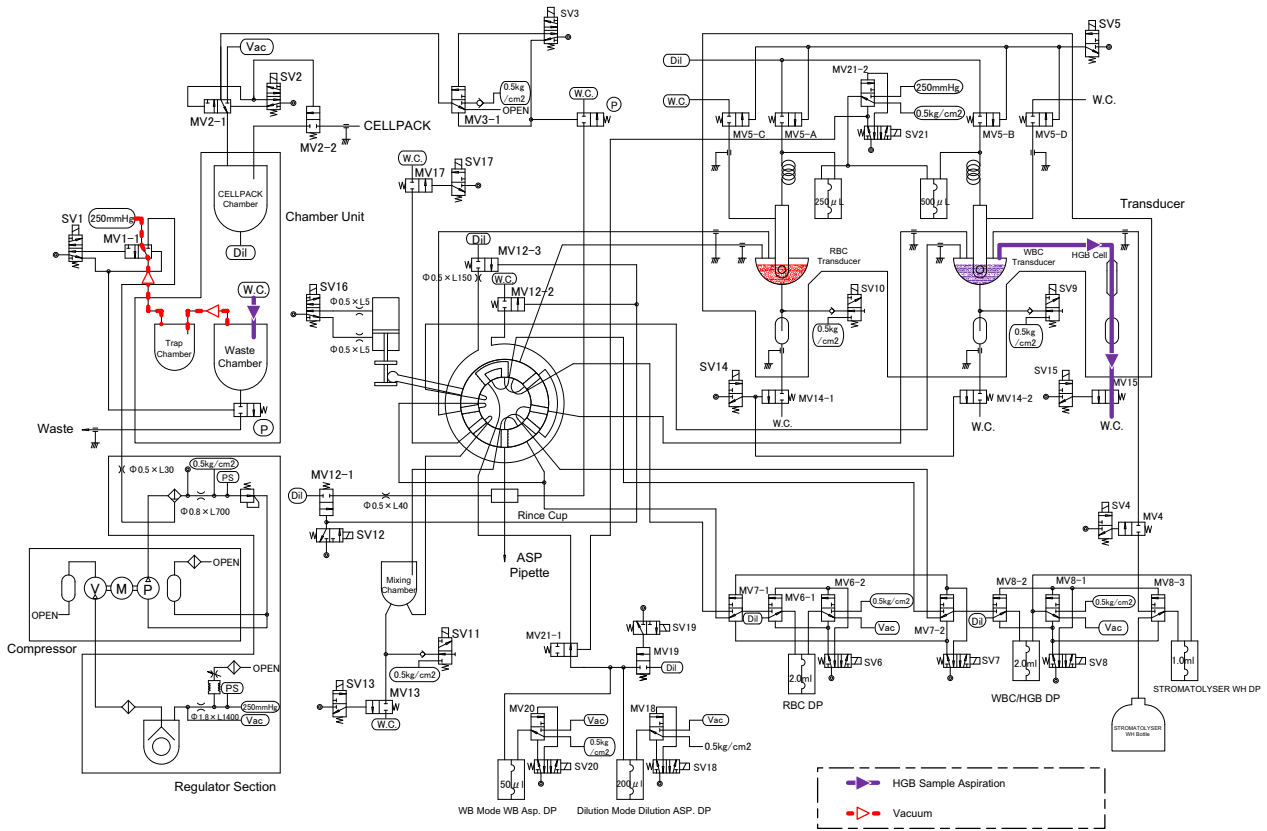

2.13.1.5) RBC/WBC analysis

1) RBC/WBC samples are aspirated to perform analysis.

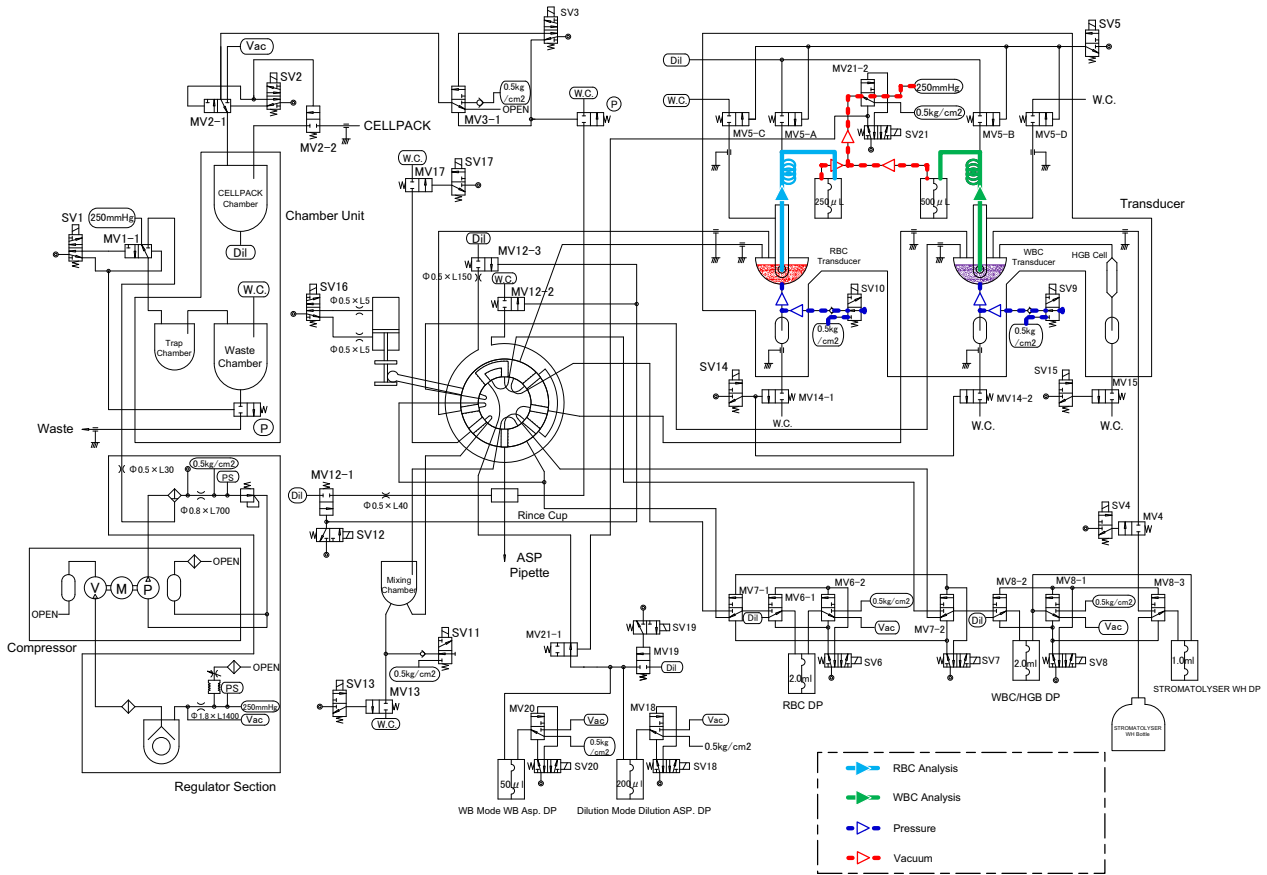

2.13.2 Pre-diluted Mode

2.13.2.1) Sample Aspiration

- 1) Samples diluted 26-fold are aspirated into SRV using Pre-diluted Mode Aspiration Diaphragm Pump.

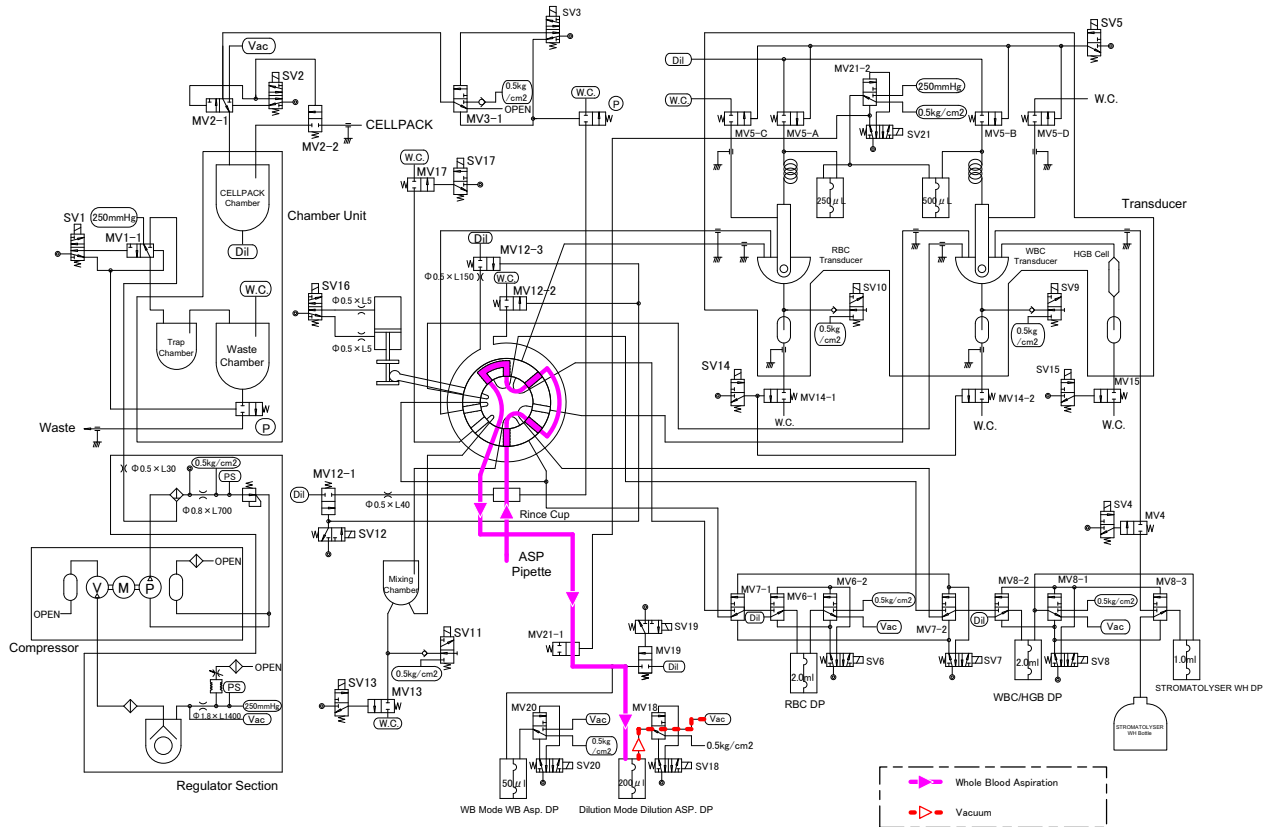

2.13.2.2) HGB blank analysis

- 1) Refer to [2.13.1.2\) HGB Blank Analysis](#).

2.13.2.3) Preparing samples for RBC/WBC analysis

- 1) SRV rotates.
- 2) Samples within SRV and diluent are dispensed into RBC Detector Unit.
- 3) Samples within SRV, diluent and lyse are dispensed into WBC Detector Unit.
- 4) Samples for RBC/WBC analysis are mixed by bubbles in the applicable detector units.

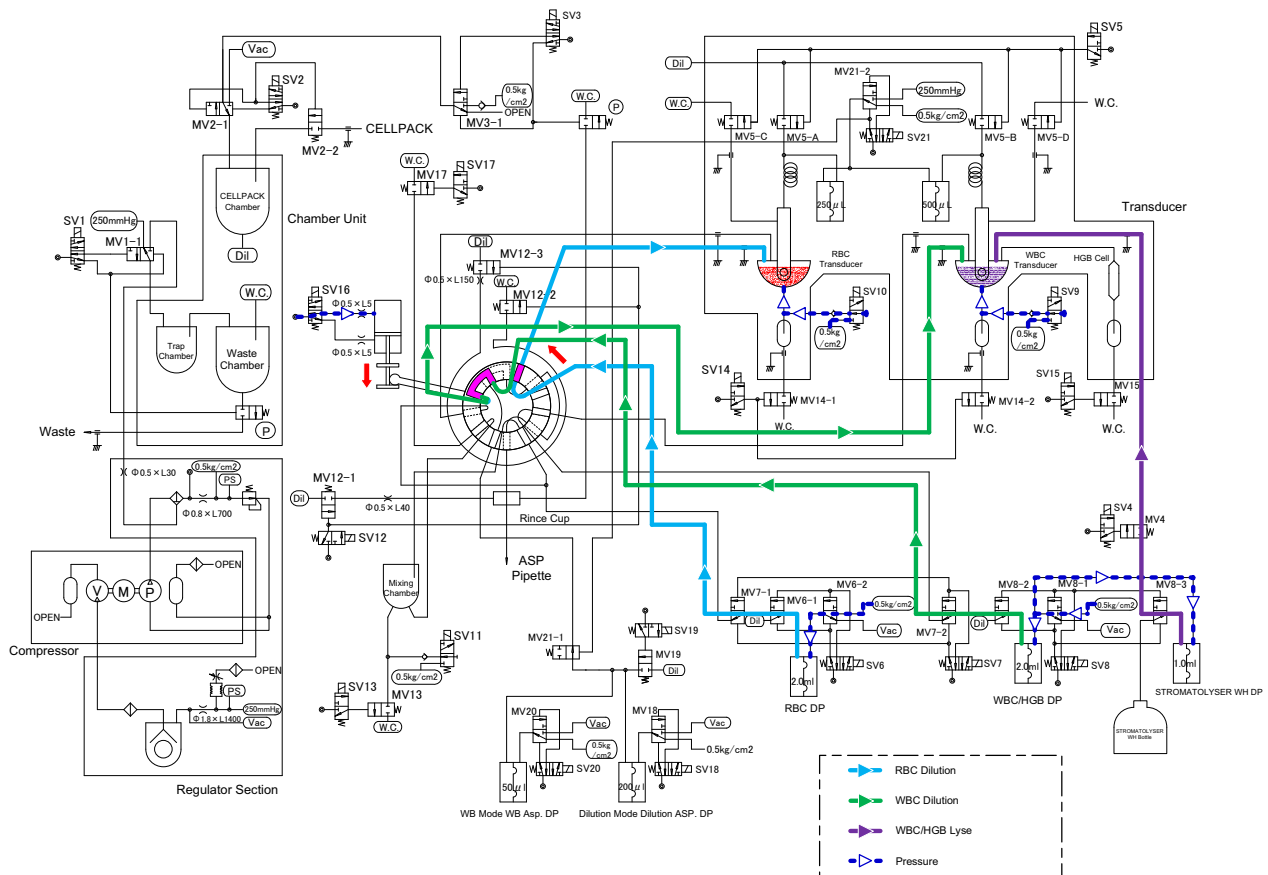

2.13.2.4) HGB Analysis

- 1) Refer to [2.13.1.4\) HGB Analysis](#).

2.13.2.5) RBC/WBC Analysis

- 1) Refer to [2.13.1.5\) RBC/WBC analysis](#).

2.14 PNEUMATIC & HYDRAULIC PARTS

Pneumatic Controls are used to regulate the air-flow, and to change the direction of flow.

Name & Symbol	Figures	Used for
<p>Regulator</p> 		<p>Regulator is used to regulate airflow rate, which is adjusted by turning the Adjustment Knob. Only on regulator, which is shown in left figure, is used in the XP series. This regulator is used to regulate 0.20MPa air pressure into 0.05MPa pressure with an air filter and auto draining mechanism.</p>
<p>Non-Return Valve</p> 		<p>The Non-return Valve permits hydraulic flow in only one direction from A to B. No hydraulic flow will occur from B to A.</p>
<p>Orifice</p> 		<p>An orifice controls the rate of airflow or the volume of air with respect to time. These orifices are identical to those used in the pneumatic and hydraulic system. There are several kinds of orifice each of which permits a different flow rate.</p>

Table 2-1 Pneumatic and Hydraulic Parts (1)

Name & Symbol	Figures	Used for						
<p data-bbox="268 210 352 232">Bellows</p> 		<p data-bbox="951 210 1324 618">The bellows unit in the XP series is used to regulate the vacuum (-0.0640MPa or more) into -0.0333MPa. This unit consists of bellows and small air tank. If the inner vacuum exceeds the mechanical pressure of bellows, vacuum is released from its top port. If the mechanical pressure exceeds the inner vacuum of bellows, vacuum increases after the top port is closed by the needle valve. (See below figures.)</p> 						
<p data-bbox="331 824 517 875">3-ports type Solenoid Valve</p>  <p data-bbox="316 1077 517 1128">5-ports type Solenoid Valve</p>  <table border="1" data-bbox="304 1308 544 1413"> <thead> <tr> <th colspan="2">Status of Solenoid Valve</th> </tr> </thead> <tbody> <tr> <td>①</td> <td>SV is turned ON.</td> </tr> <tr> <td>②</td> <td>SV is OFF.</td> </tr> </tbody> </table>	Status of Solenoid Valve		①	SV is turned ON.	②	SV is OFF.		<p data-bbox="951 799 1299 889">Two types of Solenoid valves (3-port and 5-port type) are used in the hydraulic system.</p> <p data-bbox="951 896 1324 1113">Solenoid Valves are driven by applying 12 VDC which are controlled by computer program, and are used to control the pneumatic pressure to drive Master valves, Air cylinder, or Air Bubble Mixing.</p> <p data-bbox="951 1151 1324 1431">Solenoid valve symbol has two boxes in its drawing. Arrows in these boxes indicate the status of connection. Status (1) or (2) shown in "Name & Symbol" column will be switched by the activation of solenoid valve by the activation or deactivation of solenoid valve respectively.</p>
Status of Solenoid Valve								
①	SV is turned ON.							
②	SV is OFF.							

Table 2-1 Pneumatic and Hydraulic Parts (2)

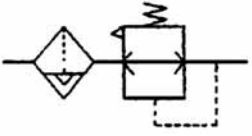
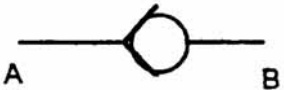
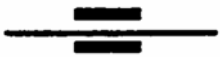
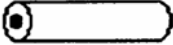

Name & Symbol	Figures	Used for						
<p>2 ports type Master Valve</p>  <p>3 ports type Master Valve</p>  <table border="1" data-bbox="284 772 555 889"> <thead> <tr> <th colspan="2">Status of Master Valve</th> </tr> </thead> <tbody> <tr> <td>①</td> <td>MV is turned ON.</td> </tr> <tr> <td>②</td> <td>MV is OFF.</td> </tr> </tbody> </table>	Status of Master Valve		①	MV is turned ON.	②	MV is OFF.		<p>Master valves in XP series are used to switch Hydraulic lines (liquid, 0.05MPa pressure, and -0.0640MPa/-0.0333MPa vacuum). Two types of Master Valve (2-port and 3-port type) are used in the hydraulic system. Master Valves are driven by 0.20MPa air pressure controlled by Solenoid valves.</p> <p>Master valve symbols has also two boxes in its drawing. Arrows and lines in these boxes indicates hydraulic ways. Status (1) or (2) shown in "Name & Symbol" column will be switched by the activation or deactivation of master valve, respectively.</p>
Status of Master Valve								
①	MV is turned ON.							
②	MV is OFF.							
<p>Sample Rotor Valve & Air Cylinder</p> <p>Sample Rotor Valve & Air Cylinder</p> 		<p>Sample Rotor Valve Mechanism is driven by the air cylinder. The air cylinder is provided with two (A and B) ports, (A) for pneumatic activation to rotate the SRV counter clockwise and the other (B) for pneumatic deactivation to reset the SRV. The 0.20MPa pressure for these action are supplied by a 3-port type solenoid valve.</p>						

Table 2-1 Pneumatic and Hydraulic Parts (3)

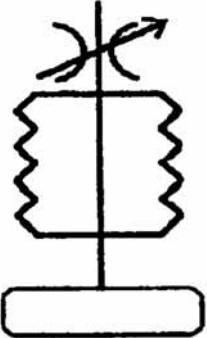
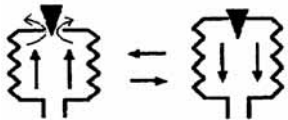
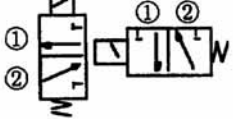
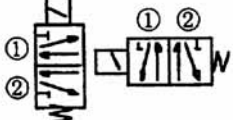

Name & Symbol	Figures	Used for
<p>Diaphragm Pump</p> <p>Pneumatics Hydraulics</p> 		<p>Seven Diaphragm Pumps are used in the hydraulic system. Diaphragm Pumps are driven by 0.05MPa air pressure and -0.0640MPa vacuum controlled by Master valves, and dispenses or aspirates constant volume of liquid. Diaphragm Pumps are drawn by left symbols in sequence flow charts.</p> <p>Diaphragm Pump has two nipples on it. One is to connect to pneumatic system (0.05MPa pressure or -0.0640MPa vacuum), and the other is to hydraulic system. Either of pressure or vacuum is always supplied to the pneumatic side nipple. If the vacuum is supplied to pneumatic side nipple, the fixed volume of liquid is aspirated into the diaphragm pump. If the pressure supplied, the fixed volume of liquid is dispensed from the diaphragm pump.</p>
<p>Manometer</p> 		<p>Ball float manometers are located in detector blocks, and are used to detect constant volume of diluted sample, which are aspirated through the transducer aperture.</p>
<p>Isolation Chamber</p> 		<p>These Isolation Chambers are used to isolate the liquid in detector block from the remaining hydraulic line in the system in order not to be influenced by the external noise through the hydraulic line.</p>

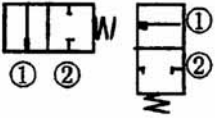
Table 2-1 Pneumatic and Hydraulic Parts (4)

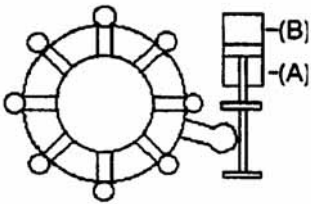

Name & Symbol	Figures	Used for
Transducer Chamber 		Diluted samples of WBC or RBC are dispensed into each transducer chamber, mixed by air bubbles, and constant volume of the sample is aspirated through the aperture.
Pressure Gauge 		Four pressure gauges are used in the system to check the following pressures or vacuums. Pneumatic unit 1: 0.20MPa 2: -0.0640MPa vacuum Main unit 3: 0.05MPa 4: -0.0333MPa vacuum
0.20MPa pressure source 		0.20MPa pressure is used to drive the master valves and SRV air cylinder. To make simple the hydraulic flow chart, the symbol in the "Name & Symbol" column is used.
Glass Chamber 		Glass chambers with float switch are used as Waste Chamber, Diluent Chamber, and lyse reagent chamber. 480mmHg or -0.0333MPa vacuum is applied into these chambers to aspirate or prime liquid. When exhausting the waste liquid in Waste Chamber, 0.05MPa is applied instead of vacuum. Float switch is provided with these chambers to prevent overflow of these chambers.
Relief Valve 		The Relief Valve releases air pressure if the supplied air pressure exceed the preset value. This valve is adjusted by turning the knurled knob.

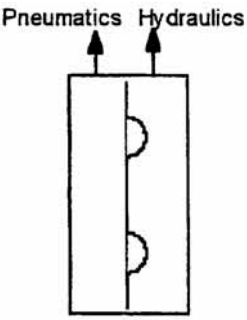
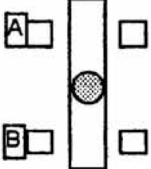
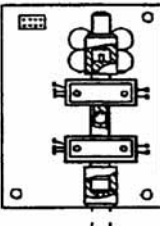
Table 2-1 Pneumatic and Hydraulic Parts (5)

CHAPTER 3 ELECTRONICS

3.1 PCB LOCATION	1
3.2 BLOCK DIAGRAM.....	2
3.2.1 Hardware Configuration	3
3.3 PCB NO. 6374 (CPU board).....	4
3.3.1 Function	4
3.3.2 Block Diagram	5
3.3.3 Cable Connection	6
3.3.4 Restoring setting values after CPU board is replaced	7
3.4 PCB NO.30012.....	10
3.4.1 Function	10
3.4.1.1 Intended use	10
3.4.1.2 Specification.....	10
3.4.2 Detailed function	11
3.4.2.1 Analog Data Logger.....	11
3.4.2.2 Driver and Sensor	12
3.4.3 PCB NO.30012 Cable Connection	13
3.4.4 Driver and Sensor map.....	14
3.4.5 Assignment of connector pin	15
3.5 PCB NO.20034/PCB NO.2135	18
3.5.1 Function	18
3.5.2 Description.....	18
3.5.3 Block Diagram	19
3.5.4 Assignment of Connector Pin	20
3.6 PCB NO.9301	22
3.6.1 Function	22
3.6.2 Descriptions	22
3.6.3 Cable Connection	22
3.6.4 Assignment of connector pin	23
3.7 PCB NO.90043	25
3.7.1 Function	25
3.7.1.1 Intended Use.....	25
3.7.1.2 Description	25
3.7.2 Detail Specifications.....	26
3.7.3 PCB NO.90043 Cable Connection	27
3.7.4 Assignment of connector pin	28
3.8 Power Supply Unit (PCB NO.4087T1).....	29
3.8.1 Function	29
3.8.2 Description.....	30
3.8.3 Block Diagram	32

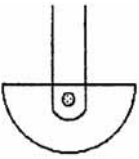
CHAPTER 3 ELECTRONICS

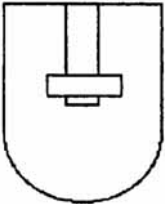
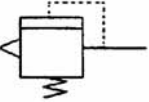
3.1 PCB LOCATION

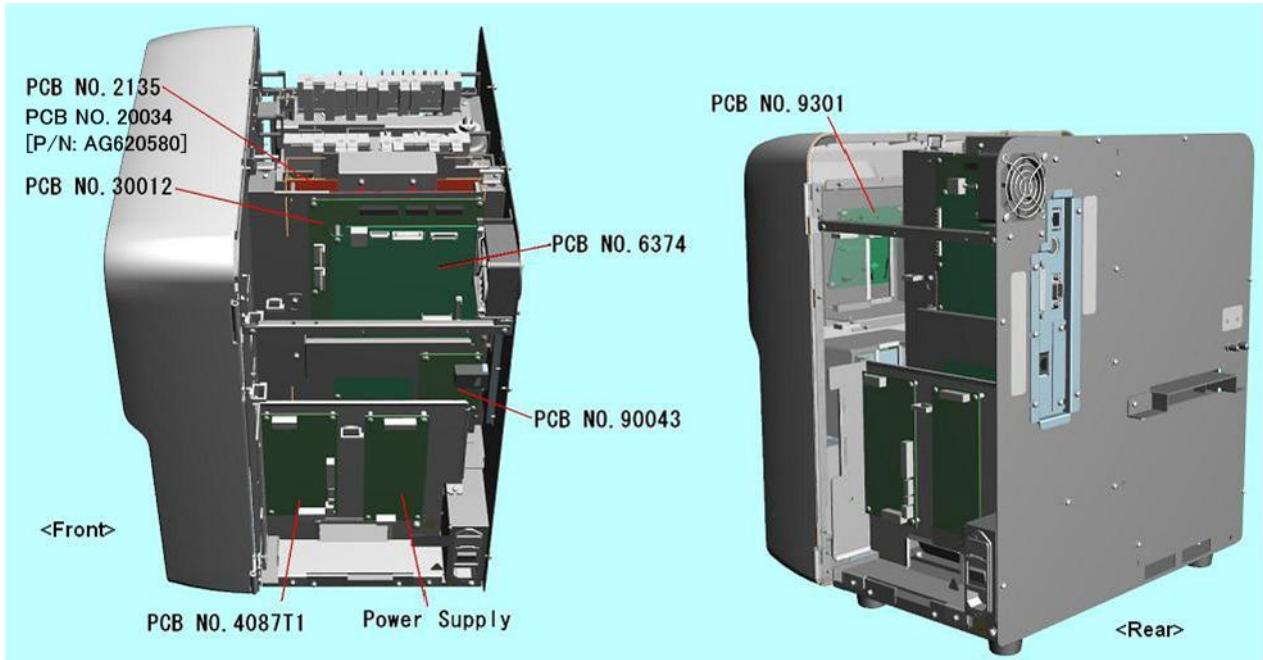

ECR 312J003: PCB NO.20034 (XP/KX) has been added.

3.2 BLOCK DIAGRAM

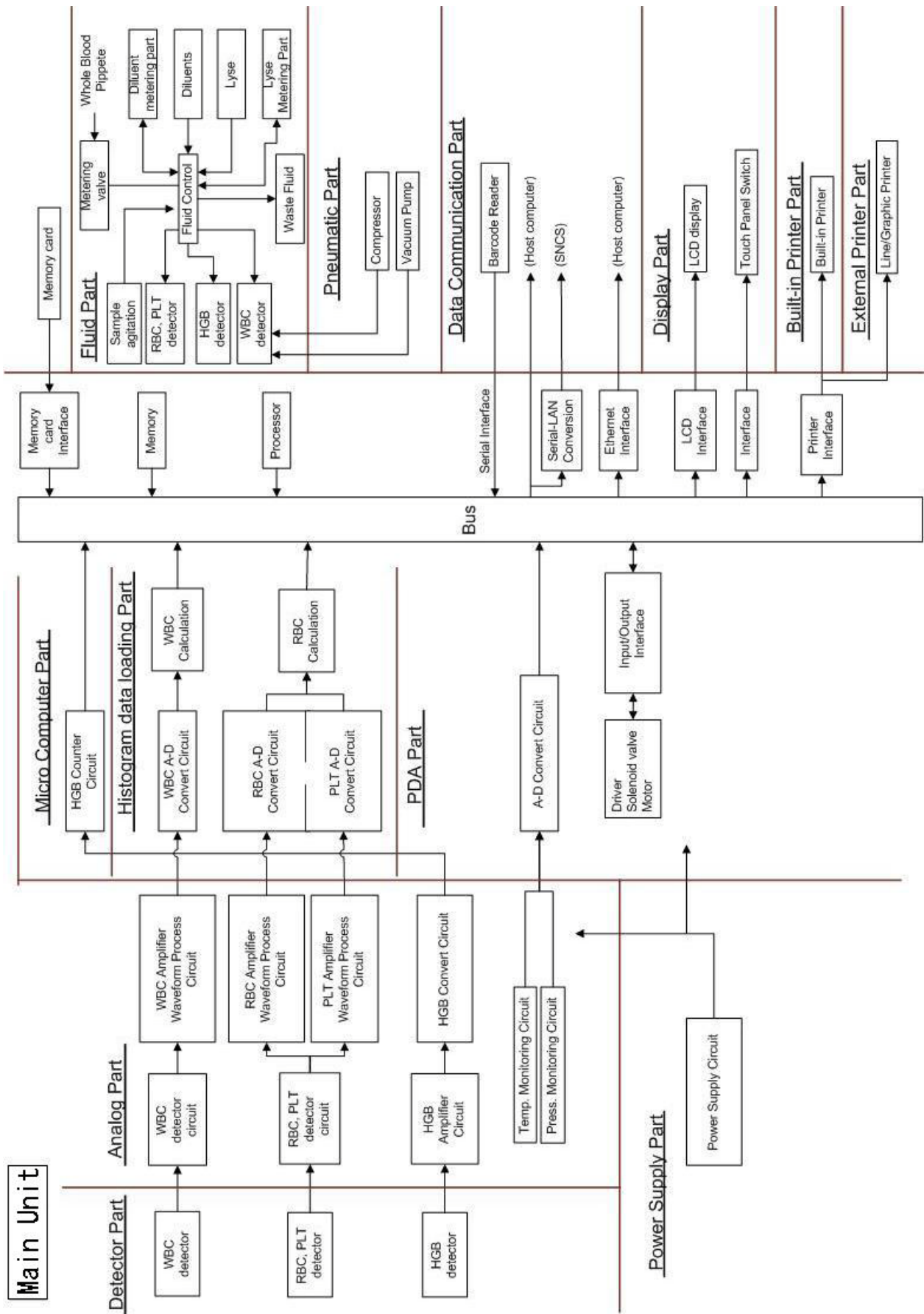

3.2.1 Hardware Configuration

Microcomputer Board (PCB No.6374T8)

- CPU : SH7709A(SH3), 133MHz
- FlashROM : 4MByte
- SDRAM : 16Mbyte
- BBU RAM : 512kByte
- Touch Panel : Analog Type
- Color LCD : 256 color, 320x240dot
- Serial : 5ch (1ch : connected to PCB No.90043 for SNCS mail sending)
- Parallel : 2ch
- SV/Sensor
- Buzzer

Analog/Driver board (PCB No.30012)

- Histogram Counter (128 division x 3ch)
- HGB Counter
- Stepping Motor: 1ch
- SV: 24ch

3.3 PCB NO. 6374 (CPU board)

NOTE:

PCB NO.6374 is commonly used on RU-20 and XP series, however, the improved version of PCB NO.6374 is used on XP series.

A white mark is put on the improved version to distinguish between the original version or improved version.

When replacing PCB NO.6374 for XP series, confirm whether there is the white mark on PCB NO.6374 or not.

(The original and improved version can be used for RU-20.)

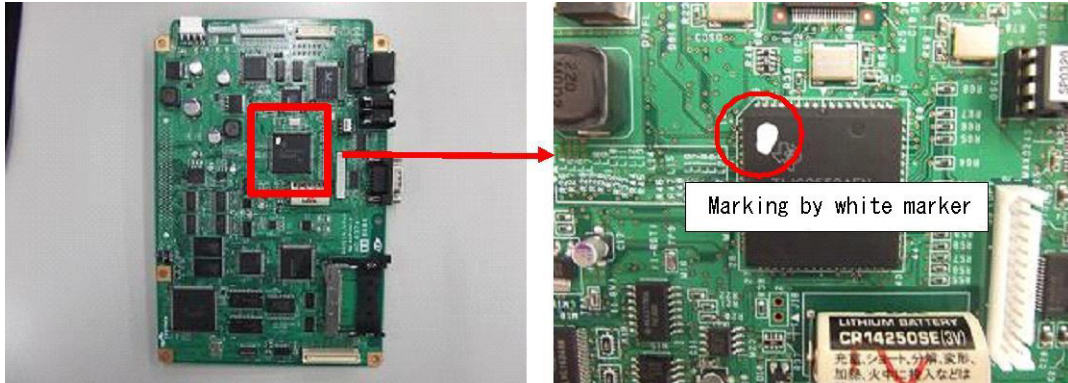

3.3.1 Function

This PCB has the SH-3RISC core CPU and LINUX-OS with 16 MB work memory(SDRAM) on board to cope with the network communication system.

CPU

The SH-3 core 32 bit RISC CPU and the 16 MB work memory (SDRAM). Internal 133 MHz, External 33MHz clock.

BBURAM

512KB (4MB SRAMx1)

Lithium battery 3.0 V-3.6 V, 1000mAh is used. 15-year backup at power OFF status is expected.

Work Memory

16MB(64MB SDRAMx2)

Program Memory

14MB (16MB flash memory x2)

PCMCIA

1 slot of compact flash connector is provided.

Calendar and Clock

Epson RTC7301SF RTC64613. For Year 2000 through 2099.

LCD

320x240 pixels, 256 colors. Controller(SED1375) with 80KB VRAM

Buzzer Controller motor

Buzzer is mounted on PCB No. 9301(relay board)

Serial Interface

RS232C port for host computer (*D-sub 9-pin (male) connector)

RS232C port for barcode reader (*DIN 8-pin round connector. 5 V is supplied to pin NO.8.)

Parallel Interface

Centronics for built-in printer (*5V for login and 8V for head motor drive are supplied.)

Centronics for external printer(*D-sub 25-pin (female) connector (Pin No.26 is not used.))

TCP/IP

Ethernet(10BASE-T) x 1

Power Supply

12 VDC is input from Switching Regulator. DC-DC converter generates 5 VDC, 500 mA for logic, and 8 VDC for built-in printer. From the 5 VDC, then 3.3VDC (15mA) is generated for pull up purpose only, and also 1.9 VDC is generated for CPU internal power supply. The power consumption is approx. 1 A.

3.3.2 Block Diagram

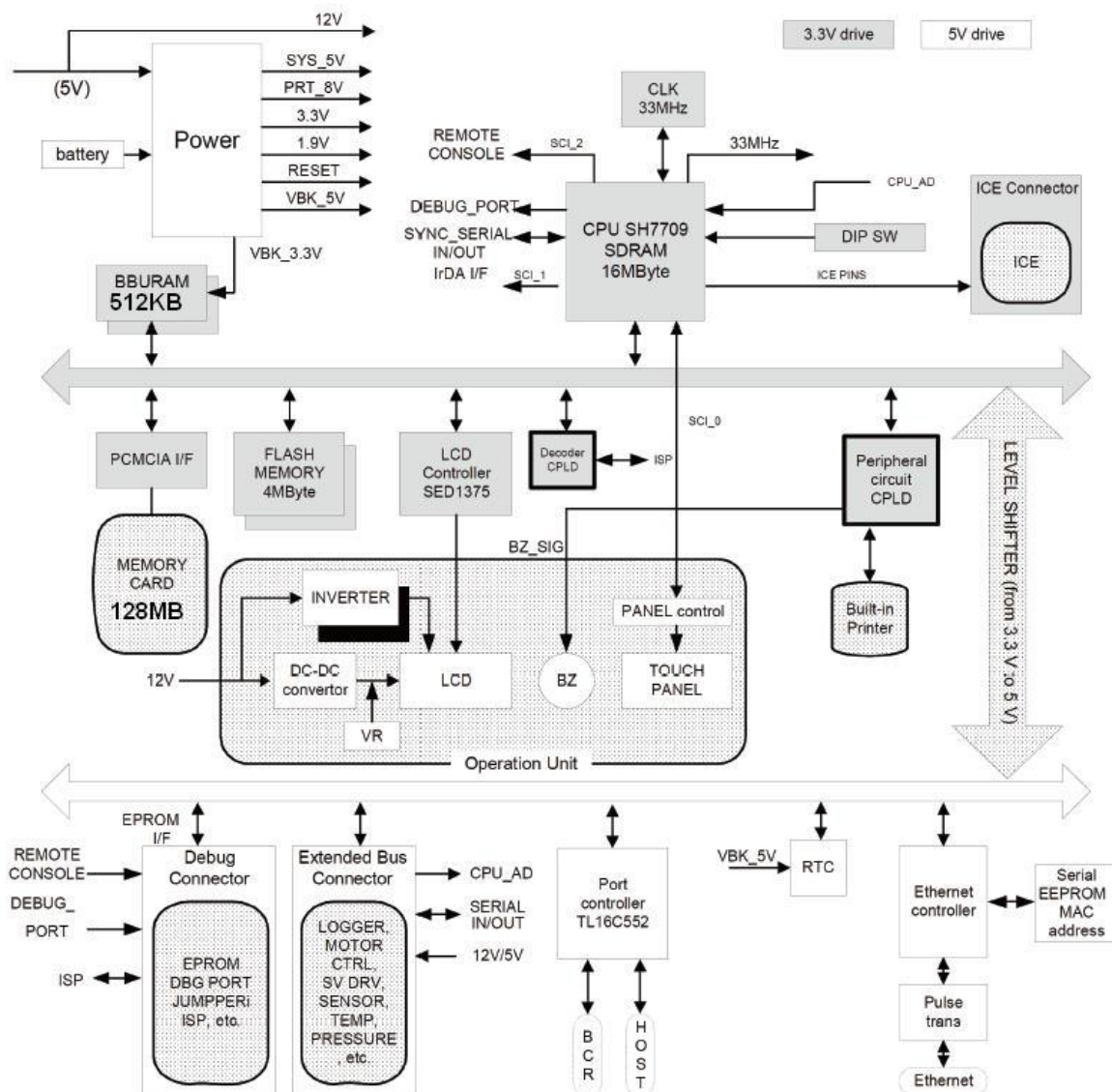

3.3.3 Cable Connection

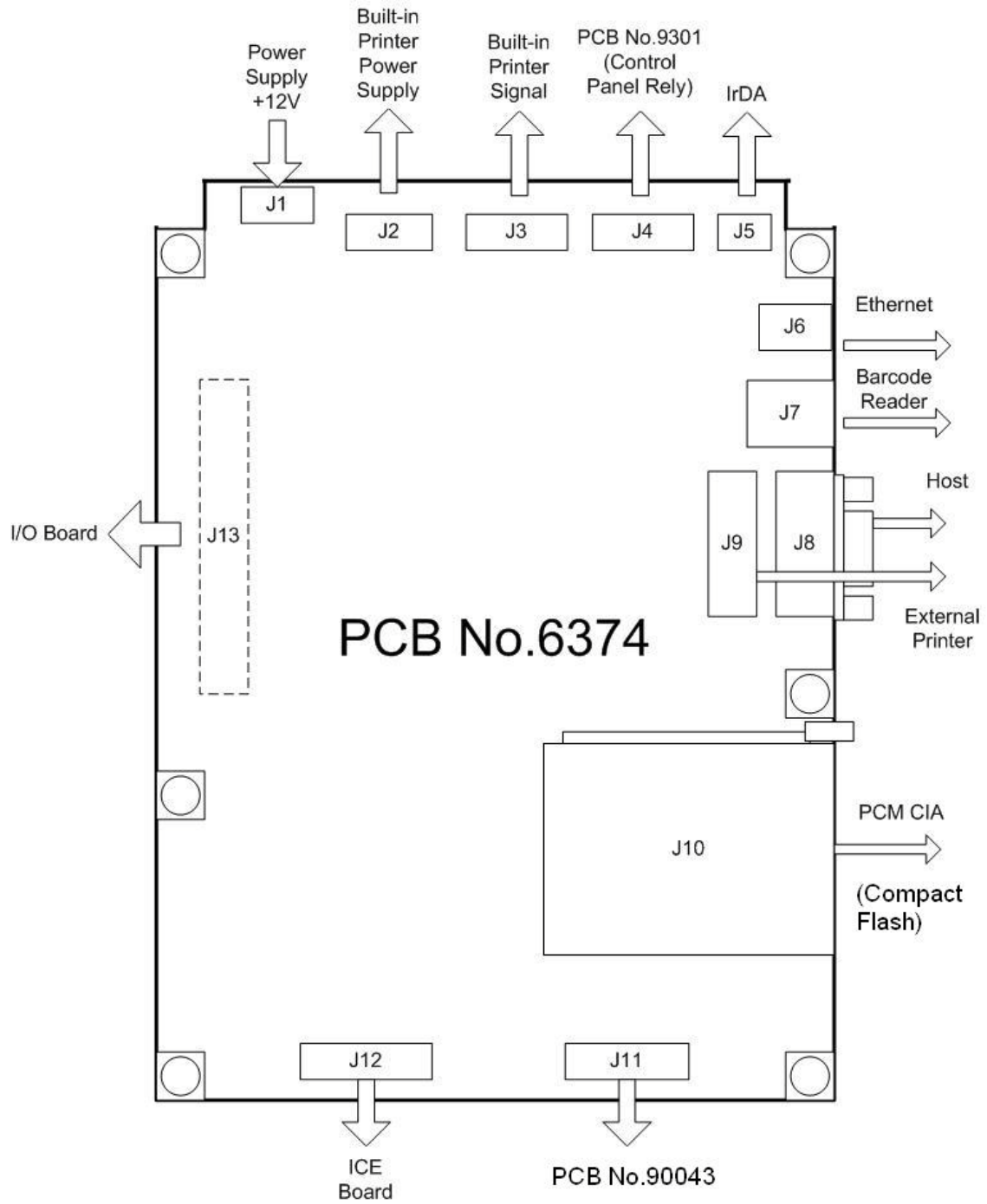

3.3.4 Restoring setting values after CPU board is replaced A

1. Print out setting values and back up BBU. (Refer to [Chapter 5 Service Program: 5.7 BBU Backup and 5.8 BBU Restore.](#))
2. Replace PCB.
3. Turn ON the power to the instrument.
4. Press [Init.] button to initialize setting values.

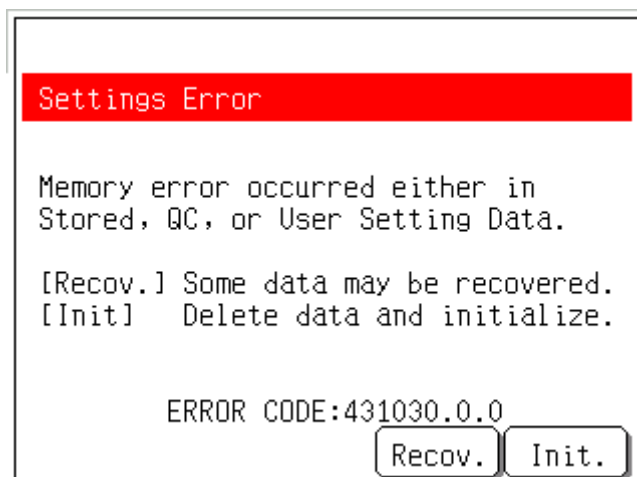

5. Press [Execute] button to initialize.

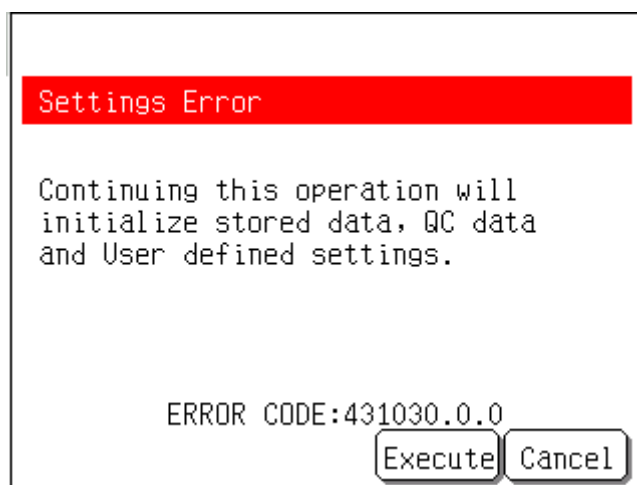

A TB201377: Added "Restoring setting values after CPU board is replaced".

6. Turn OFF the power. Then, turn ON the power once again.

Shutdown sequence was completed.
Turn OFF the power.

7. After the instrument is started, press [BBU Restore] button.

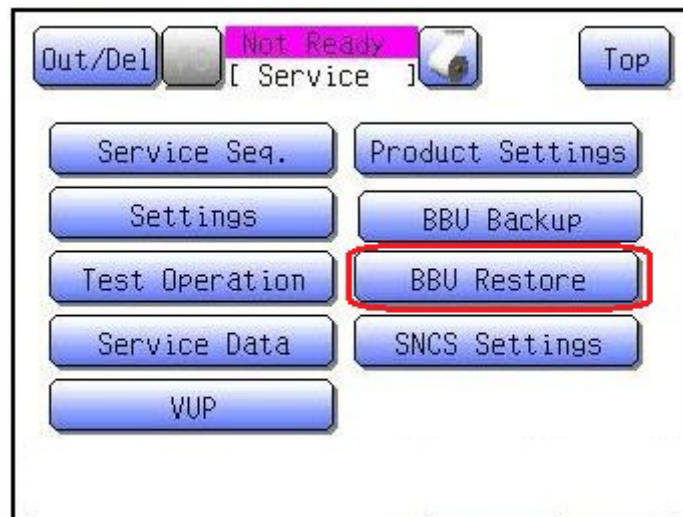

8. Press [OK] button.

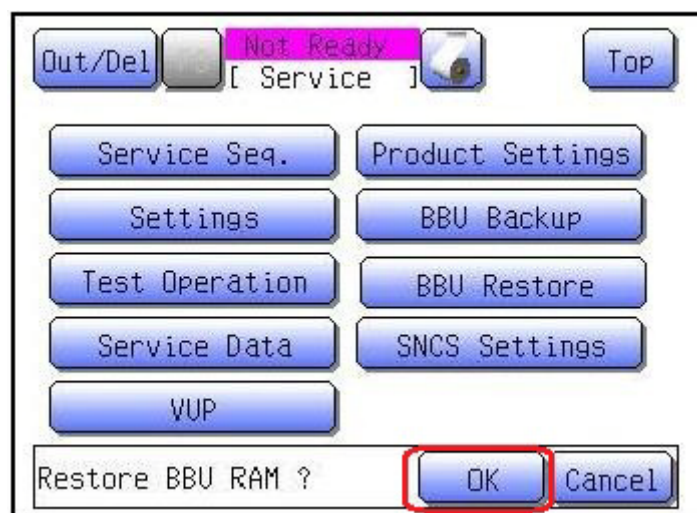

TB201377: Added "Restoring setting values after CPU board is replaced".

9. Turn OFF the power.

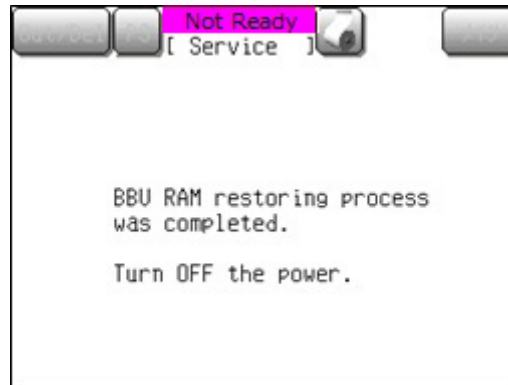

10. Turn ON the power.
11. Print out and check setting values.

TB201377: Added "Restoring setting values after CPU board is replaced".

3.4 PCB NO.30012

3.4.1 Function

This PCB is analog, logger and driver board for XP series, and connect to PCB No.6374, that is CPU board, and PCB NO.20034 (XP/KX) [P/N: AG620580]/PCB No.2135, that is waveform processing board. (Data logger, solenoid valve/stepping motor driver and sensor) A

3.4.1.1 Intended use

This board is used as analog/driver board for XP series.

While its analog board has the function as data logger and sensor for XP series, its driver board also has sensor of solenoid valve driver, stepping motor driver and float switch.

3.4.1.2 Specification

(1) Resistance Detection

Digitalize pulse height of RBC, PLT, WBC and store the data into memory.

(2) Hgb (Hemoglobin) measurement

Digitalize pulse duration of count gate signal and store the data into memory.

(3) Sensor

Relay signals of pressure, temperature and clog from PCB NO.20034 (XP/KX) [P/N: AG620580]/PCB No.2135 to PCB NO.6374. A

Monitor Start Switch and Float Switch.

(4) SV Driver

Receive serial signal from CPU and drive solenoid valve, relay control, pneumatic control relay and pneumatic fan (24ch)

(5) Stepping Motor

Constant voltage drive(1ch)

A 312J003

3.4.2 Detailed function

3.4.2.1 Analog Data Logger

(1) Control Circuit for resistance detector

Output control signals of WBC, RBC detective current and clog removal relay toward PCB NO.20034 (XP/KX) [P/N: AG620580]/PCB NO.2135. A

(2) Detection Circuit of RBC, PLT and WBC

Receive peak hold signal of RBC, PLT, WBC and AD Start signal from PCB NO.20034 (XP/KX) [P/N: AG620580]/PCB NO.2135 and send A/D converted signal to data logger. A

(3) Hgb Circuit

Receive PCB count gate signal from PCB NO.20034 (XP/KX) [P/N: AG620580]/PCB NO.2135 and convert to pulse. A

(4) Electron volume

Transmit the setting signal of electron volume(AD8403AR) for WBC, RBC gain adjustment of PCB NO.20034 (XP/KX) [P/N: AG620580]/PCB NO.2135 with FPGA. A

Electron Volume	Application
AD8403AR10 (10 kΩ)	RBC pre-amplify gain adjustment
	RBC pre-amplify gain adjustment

(10kΩ)			
Address		Data	
A1	A0	D7	D0
0	0	----	
0	1	----	
1	0	R_GAIN	
1	1	W_GAIN	
MSB		→	LSB

A 312J003

3.4.2.2 Driver and Sensor

(1) Stepping Motor Driver

When receiving signal from Motor controller of FPGA at driver IC, Stepping Motor is driven.
Power supply for motor drive : Constant voltage + 12 Vdc

Motor Driver IC

STM 1 : SSM5H12TU (TOSHIBA) Current : 1.9 A (at 25°C)

(2) Serial Driver

When receiving serial signal from M - I/O, convert it from serial to parallel and control each ports.

Serial - Parallel conversion IC

- a) Shift resistor IC74VHC595 (8bit, 3-state)
- b) Create shift resistor within FPGA

Driver IC

SSM5H12TU (TOSHIBA) : Output withstand voltage : 30V, Current 1.9 A

Control ports

Solenoid valve	:	21ch
Pneumatic fan on/off Relay	:	1ch
Relay for clog removal power	:	1ch
Pneumatic on/off relay	:	1ch
(Stepping motor excitation)	:	1ch (Shift Resistor in FPGA)
Detector clog monitoring switch	:	1ch (Shift Register in FPGA)

(3) Sensor

(4) Serial Input

Convert signal from each sensor from parallel to serial and send CPU board.

Control ports 8ch

Micro switch	:	1ch (Start SW)
Float switch	:	3 ch (diluent, waste fluid, external3 WP reagent)
DIP switch	:	3 ch (Not mounted)
Spare	:	4 ch

3.4.3 PCB NO.30012 Cable Connection

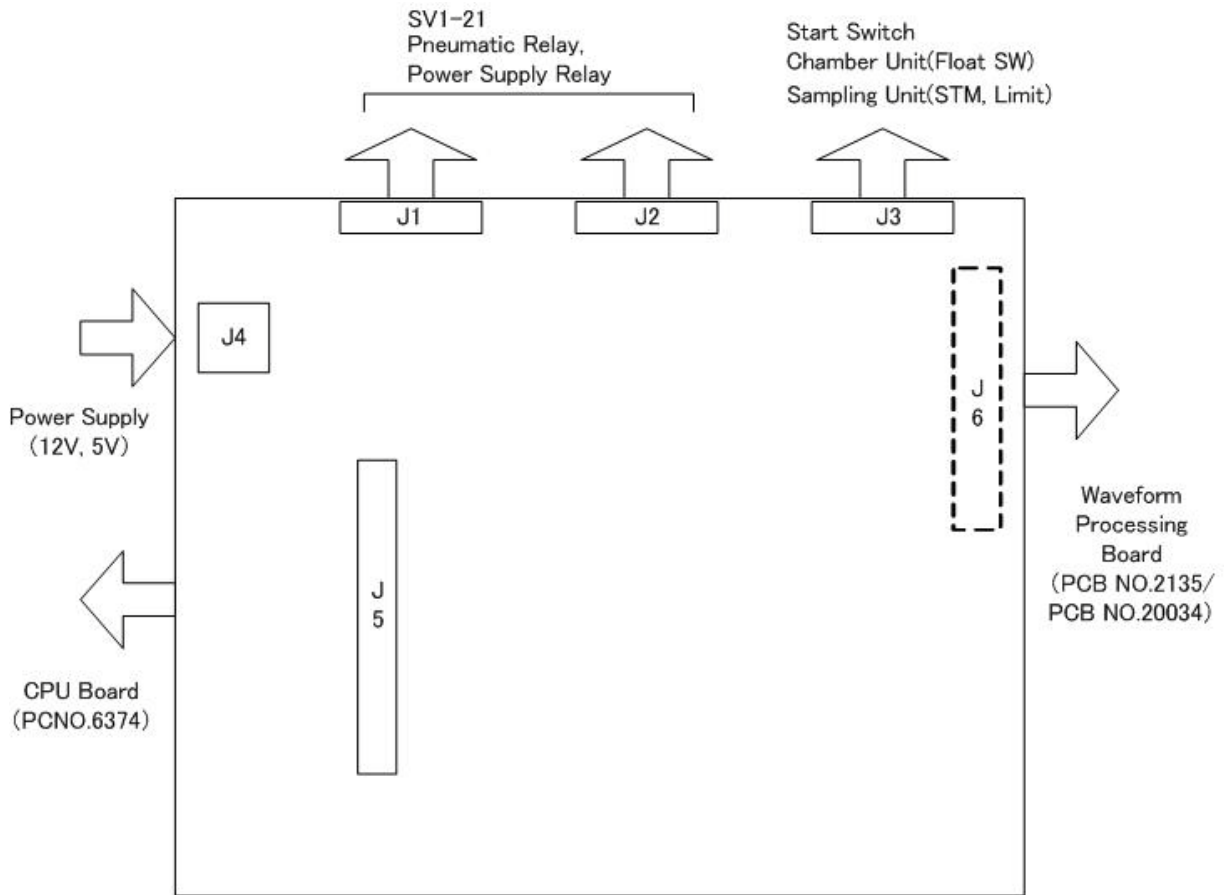

* Through J4, power supply volume is 12 V only. 5V and $\pm 15V$ are supplied through J5 from PCB NO. 6374 and J6 from PCB NO.20034 (XP/KX) [P/N: AG620580]/PCB NO.2135, respectively. A

A 312J003

3.4.4 Driver and Sensor map

(1) Stepping motor

No	Application	Movement Direction CW	Limit SW [logic at ON]
STM1	Sampling Unit	Top	CCW (down) [low]

(2) Control map for serial output

No	Data bit							
	7	6	5	4	3	2	1	0
1	SV8	SV7	SV6	SV5	SV4	SV3	SV2	SV1
2	SV16	SV15	SV14	SV13	SV12	SV11	SV10	SV9
3	SV24 pnuematic	SV23 Clog removal	SV22 pnuematic FAN	SV21	SV20	SV19	SV18	SV17
4							CLOG switch	STM excitation

3.4.5 Assignment of connector pin

<J1>(S.V Output 1)

Connector : DF11 - 32DP - 2DSA (HIROSE)

Pin No.	Signal	Pin No.	Signal
1	+ 12 V	2	SV1 - S
3	+ 12 V	4	SV2 - S
5	+ 12 V	6	SV3 - S
7	+ 12 V	8	SV4 - S
9	+ 12 V	10	SV5 - S
11	+ 12 V	12	SV6 - S
13	+ 12 V	14	SV7 - S
15	+ 12 V	16	SV8 - S
17	+ 12 V	18	SV9 - S
19	+ 12 V	20	SV10 - S
21	+ 12 V	22	SV11 - S
23	+ 12 V	24	SV12 - S
25	+ 12 V	26	SV13 - S
27	+ 12 V	28	SV14 - S
29	+ 12 V	30	SV15 - S
31	+ 12 V	32	SV16 - S

<J2>(S.V Output 2)

Connector : DF11 - 16DP - 2DSA(HIROSE)

Pin No.	Signal	Pin No.	Signal
1	+ 12 V	2	SV17 - S
3	+ 12 V	4	SV18 - S
5	+ 12 V	6	SV19 - S
7	+ 12 V	8	SV20 - S
9	+ 12 V	10	SV21 - S
11	+ 12 V	12	SV22 - S
13	+ 12 V	14	SV23 - S
15	+ 12 V	16	SV24 - S

<J3>(Motor control output/Sensor input)

Connector : DF11 - 22DP - 2DSA(HIROSE)

Pin No.	Signal	Pin No.	Signal
1	+ 12 V	2	+ 12 V
3	STM - A	4	STM - B
5	STM - #A	6	STM - #B
7	GND	8	FSW1
9	GND	10	FSW1
11	GND	12	CCW_LIM
13	GND	14	CW_LIM
15	GND	16	START_SW
17	GND	18	SW6
19	GND	20	SW6
21	VCC	22	VCC

<J4>(Power Supply)

Connector :

Pin No.	Signal	Pin No.	Signal
1	+ 12 V	2	(5V)
3	GND	4	GND

<J5>Bus Connector

Pin No.	Signal	Pin No.	Signal
1	GND	51	GND
2	CKIO	52	GND
3	GND	53	GND
4	DB0	54	DB1
5	DB2	55	DB3
6	DB4	56	DB5
7	DB6	57	DB7
8	DB8	58	DB9
9	DB10	59	DB11
10	DB12	60	DB13
11	DB14	61	DB15
12	5V	62	5V
13	5V	63	5V
14	5V	64	5V
15	AB0	65	AB1
16	AB2	66	AB3
17	AB4	67	AB5
18	AB6	68	AB7
19	AB8	69	AB9
20	---	70	---
21	---	71	---
22	---	72	---
23	GND	73	GND
24	---	74	---
25	---	75	---
26	---	76	---
27	---	77	AB23
28	AB24	78	GND
29	EX8CSb	79	EX16CSb
30	---	80	---
31	GND	81	GND
32	---	82	---
33	RDb	83	---
34	WE0b	84	---
35	---	85	---
36	---	86	---
37	---	87	---
38	---	88	GND
39	GND	89	GND

Pin No.	Signal	Pin No.	Signal
40	SERCLK	90	SERSVLTCH
41	SERISENS	91	SERSV
42	SERSENSLTCHb	92	SERENb
43	5V	93	5V
44	3.3V	94	3.3V
45	GND	95	GND
46	RESET/	96	GND
47	GND	97	GND
48	ANA0	98	ANA1
49	ANA2	99	GND
50	GND	100	GND

<J6>(Analog I/F)

Connector : PCN10C - 44S - 2. 54DSA(HIROSE)

Pin No.	Signal	Pin No.	Signal
1 (1A)	A + 5V	23 (1B)	A + 15 V
2 (2A)	AGND	24 (2B)	A - 15 V
3 (3A)	AGND	25 (3B)	P - PLS (A)
4 (4A)	AGND	26 (4B)	R - PLS (A)
5 (5A)	AGND	27 (5B)	W - PLS (A)
6 (6A)	AGND	28 (6B)	*P - ADSTART
7 (7A)	AGND	29 (7B)	*R - ADSTART
8 (8A)	AGND	30 (8B)	*W - ADSTART
9 (9A)	BOARDSEL	31 (9B)	*HGB_COUNT
10 (10A)	VCC	32 (10B)	*HGB_START - S
11 (11A)	*W_TDON-S	33 (11B)	*R_TDON - S
12 (12A)	VCC	34 (12B)	VCC
13 (13A)	*CLN-S	35 (13B)	AGND
14 (14A)	AGND	36 (14B)	VCC
15 (15A)	PS_0.5	37 (15B)	PS_250
16 (16A)	R.CLOG	38 (16B)	TEMP
17 (17A)	AGND	39 (17B)	W.CLOG
18 (18A)	AGND	40 (18B)	AGND
19 (19A)	*PDATEST	41 (19B)	AGND
20 (20A)	VCC	42 (20B)	*PM - SDI - S
21 (21A)	N.C.	43 (21B)	*PM - CLK - S
22 (22A)	N.C.	44 (22B)	*PM - CS - S

3.5 PCB NO.20034/PCB NO.2135

3.5.1 Function

PCB NO.20034 (XP/KX) [P/N: AG620580]/PCB NO.2135 is the analog main board. A

3.5.2 Description

(1) RBC/PLT Detection Circuit

Amplifies the blood signal transmitted from the RBC detector, discriminates it into RBC and PLT signals, and then sends the peak hold signal to the digital board. The RBC/PLT circuit also internally generates an A/D START signal for each signal and sends it to the digital board. The peak hold and A/D START signals are transmitted as they are generated. The start and end of counting are controlled on the digital board in accordance with the predetermined sequence.

(2) WBC Detection Circuit

Amplifies the blood signal from the WBC detector and sends the peak hold signal to the digital board. The WBC circuit also internally generates an A/D START signal sends it to the digital board. The peak hold and A/D START signal are transmitted as they as generated.

* Blood cell signal amplification method

The analog main board uses a current-responsive amplifier to detect the blood cell signal. Below is an overview of this method.

E serves as constant power supply within the blood cell signal band, according to the operation of C.

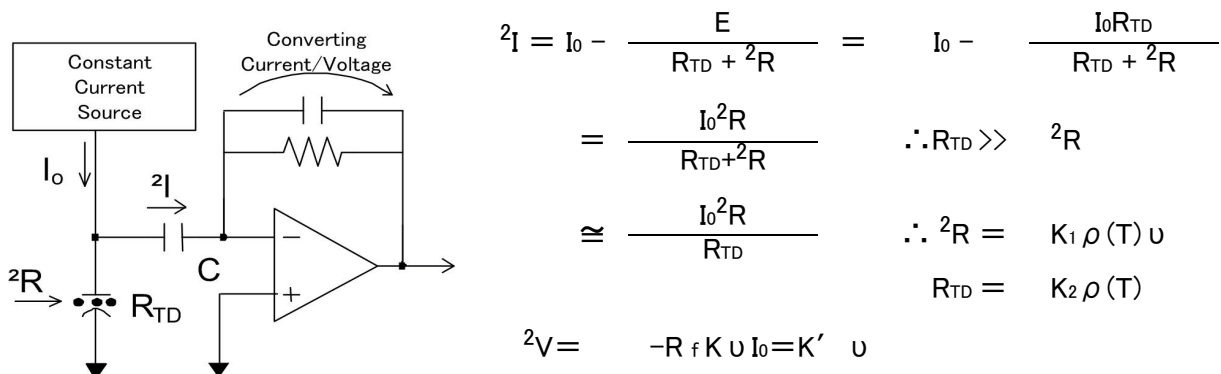

(3) HGB Detection Circuit

Firstly converts the photodiode current signal transmitted from the HGB unit into a voltage signal and then into a time signal. The digital board then converts the time signal into pulses. The constant-current circuit for the LED(555nm), light source for HGB measurement, is also included in the configuration.

(4) Temperature Monitoring Circuit

Measures the ambient temperature in the vicinity of detectors. The thermistor temperature (TEMP) is transmitted as an analog signal, which is then converted to a digital signal on the digital board.

(5) Clog Detection Circuit

Measures the DC voltage in detectors. The DC voltage level is transmitted as analog signal, which is then converted to a digital signal on the digital board.

A 312J003

(6) Pressure Detection

Two pressure sensing (monitoring) systems, 0.5kg/cm², 250mmHg, are adopted, using adjustment-free pressure sensors, The sensor outputs are converted to pressure values by the formulas below.

- 0.049 MPa

$$P = (X - 0.2)/4.41 \text{ [MPa]}$$

- 0.0333 MPa

$$V = (X - 0.2)/0.006 \text{ [MPa]}$$

* Here, C represents sensor output(V).

3.5.3 Block Diagram

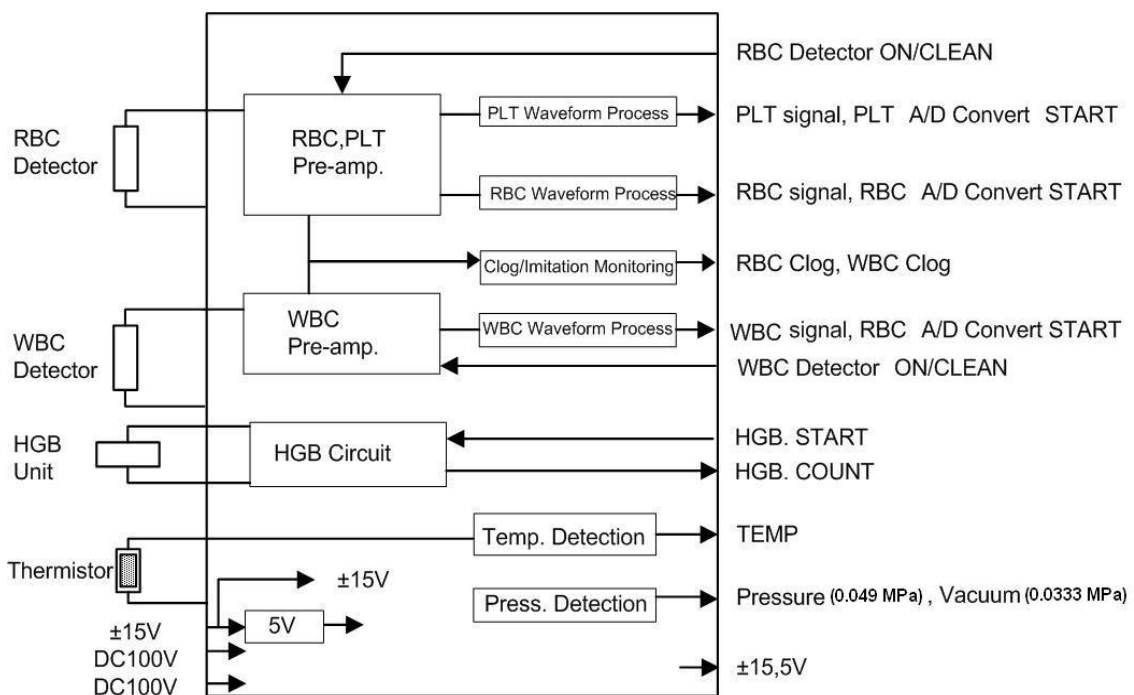

PCB NO.20034/PCB NO.2135 Block Diagram A

A 312J003

3.5.4 Assignment of Connector Pin

(1) J1 ($\pm 15V$, DC100V : B6PS - VH)

Pin NO.	Signal	Pin NO.	Signal
1	DC100V	4	+ 15V
2	GND (DC100V)	5	GND
3	A.GND	6	- 15V

(2) J2(AC100V : B3PS - VH)

Pin NO.	Signal
1	AC100V(H)
2	AC100V(C)
3	A.GND

(3) J3 (RBC : FFC - 04LAMEP1)

Pin NO.	Signal	Pin NO.	Signal
1	Used to prevent disconnection	3	RBC.TD (+)
2	A.GND (Shield)	4	RBC.TD (-)

(4) J4 (WBC : FFC - 04LAMEP1)

Pin NO.	Signal	Pin NO.	Signal
1	A.GND (Shield)	3	WBC.TD (+)
2	Used to prevent misconnection	4	WBC.TD (-)

(5) J5 (HGB : FFC - 06LBMEP1)

Pin NO.	Signal	Pin NO.	Signal
1	HGB.SIG	4	-
2	HGB.GND	5	A.GND
3	HGB.LED	6	A.GND

(6) J6 (Thermistor : FFC - 04LAMEP1)

Pin NO.	Signal	Pin NO.	Signal
1	TH	3	NC
2	NC	4	TH(GND)

(7) J7 (Digital PC : PCN10HA - 44PA - 2.54DSA)

Pin NO.	Signal	Pin NO.	Signal
1A	+ 5V	1B	+ 15V
2A	GND	2B	- 15V
3A	GND	3B	P.SIG
4A	GND	4B	R.SIG
5A	GND	5B	W.SIG
6A	GND	6B	P.A/D.START/
7A	GND	7B	R.A/D.START/
8A	GND	8B	W.A/D.START/
9A	NC	9B	HGB.COUNT (SIG)/
10A	HGB.START (+ 5V)	10B	HGB.START (SIG)/
11A	W.TD.ON (SIG)/	11B	R.TD.ON (SIG)/
12A	W.TD.ON (+ 5V)	12B	R.TD.ON (+ 5V)
13A	CLN (SIG)/	13B	GND
14A	GND	14B	CLN (+ 5V)
15A	PS.0.5	15B	PS.250
16A	R.GLOG	16B	TEMP
17A	GND	17B	W.GLOG
18A	GND	18B	GND
19A	NC	19B	GND
20A	DVR (5V)	20B	D.SDI
21A	NC	21B	D.CLK
22A	NC	22B	D.CS/

(8) J8 (FFC-6BMEPI), J9 (DIC-252) are not used. * PCB NO.20034 only.

(However, check that J9 is connected to the point between Pin No.3 and Pin No. 4 of J8.) A

A 312J003

3.6 PCB NO.9301

3.6.1 Function

This board is LCD relay board. Touch panel controller and buzzer are mounted on this board.

3.6.2 Descriptions

- (1) Touch Panel Control
Has the interface with the analog touch panel.
- (2) LCD Control signal Relay
Relays the signal from the CPU board to LCD.
- (3) LCD Power supply
DC-DC Converter generates the power for the LCD(V_{EE}). The voltage can be adjusted by VR for contrast adjustment.
- (4) Buzzer
Buzzer level is adjusted to 4 level by digital signals from CPU.
- (5) CFL
Supplies +12V to the inverter (for LCD backlight). Backlight amount is adjusted by the signal from CPU.

3.6.3 Cable Connection

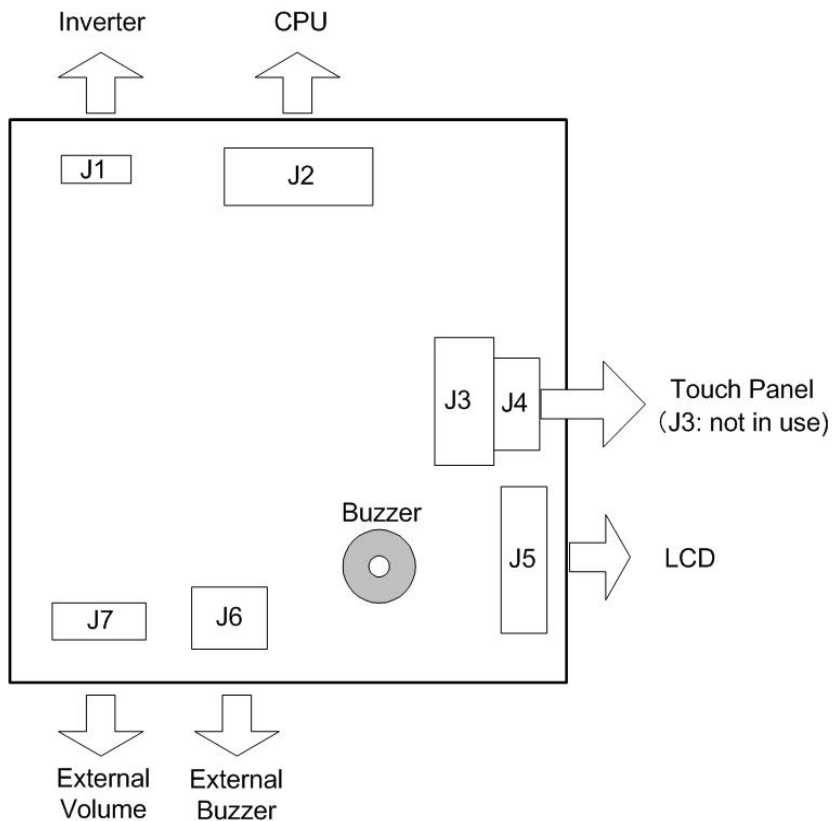

3.6.4 Assignment of connector pin

(1) J1 : CFL

Pin NO.	Function
1	12V
2	GND (12V)
3	12V
4	CFLDOWN
5	GND (12V)

(2) J2 : CPU

Pin NO.	Function	Pin NO.	Function
1	GND (5V)	16	D0
2	GND (5V)	17	GND (5V)
3	5V	18	GND (5V)
4	5V	19	CFLDOWNb
5	FRAME	20	BZSIG
6	LOAD	21	BZCTR[1]
7	CP	22	BZCTR[0]
8	DISPOFFb	23	TxD
9	D7	24	RxD
10	D6	25	RESETb
11	D5	26	GND (12V)
12	D4	27	12V
13	D3	28	12V
14	D2	29	GND (12V)
15	D1	30	GND (12V)

(3) J3 : Touch panel (Unused)

Pin NO.	Function
1	YL
2	YLref
3	YUewd
4	YU
5	XR
6	XL
7	Xlref
8	XRref

(4) J4 : Touch panel

Pin NO.	Function
1	YU
2	XR
3	YL
4	XL

(5) J5 : LCD

Pin NO.	Function
1	FRAME
2	LOAD
3	CP
4	DISPOFFb
5	VCC
6	GND
7	VEE
8	D7
9	D6
10	D5
11	D4
12	D3
13	D2
14	D1
15	D0

(6) J6 : External buzzer

Pin NO.	Function
1	12V
2	BZ
3	GND (12V)
4	GND (12V)

(7) J7 : External volume (LCD brightness)

Pin NO.	Function
1	CONT - A
2	GND
3	CONT - B
4	GND

3.7 PCB NO.90043

3.7.1 Function

This board is transmission board of SNCS for XP series and connect with PCB NO.6374, that is CPU board.

3.7.1.1 Intended Use

This board is used as transmission board of SNCS mail for XP series.

Serial data that is sent from PCB NO.6374 is converted to mail form and transmitted to network.

3.7.1.2 Description

- Transmit a message to mail server by instructions from serial instruments.
- Set the XPort04R network and destination settings by instructions from serial instruments.
- Get IP address using DHCP server
- Name resolution using DNS server
- Update firmware

3.7.2 Detail Specifications

- XPORT04R

Device : LANTRONIX XP1001000-04R

OS : μ ITORON

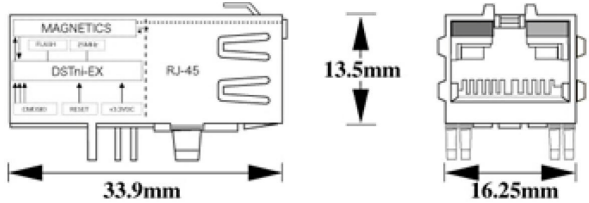
Architecture	CPU	DSTni-EX (16bit,48MHz)
	SRAM	256 kbyte
	FlashROM	512 kbyte
	Firmware	Can be upgraded via TFTP and serial port
Serial I/F	Interface	CMOS, Asynchronous Communication
	Transmission Speed	300 - 921kbps at 88MHz
	Parity	odd/even/none
	Bit Length	7, 8 bit / 1, 2 stop bit
	Control signal	DTR/DCD, CTS/RTS
	Flow control	Hardware, software
	Programmable I/O(PIO)	3 GPIOPin (Available software setting)
Network I/F	Connector	RJ - 45
	Interface	100BASE - TX/10BASE - T automatic recognition
	Protocol	TCP/IP, UDP/IP,ARP, ICMP, SNMP, TFTP, Telnet, DHCP, BOOTP, HTTP, AutoIP, SMTP
Communication transposition		Ethernet : Version 2.0 / IEEE 802.3
LED display		100BASE - TX/10BASE - T, Link/Activity (Full Duplex, Half Duplex)
Management		SNMP(Read only), Telnet, Serial, Built-in WEB server, Exclusive utility
Built-in WEB server		Available to store HTML, Java applet Storage volume : 384KB
Power supply	Input Voltage	DC3.3V
	Current Consumption	Approx. 230 mA (Operate at 48 MHz)
Ambient Temperature	Under operation	- 40 - 85°C(Operate at 48 MHz)
	Under standby	- 40 - 85°C
Size		
Weight		9g

 TB201284

3.7.3 PCB NO.90043 Cable Connection

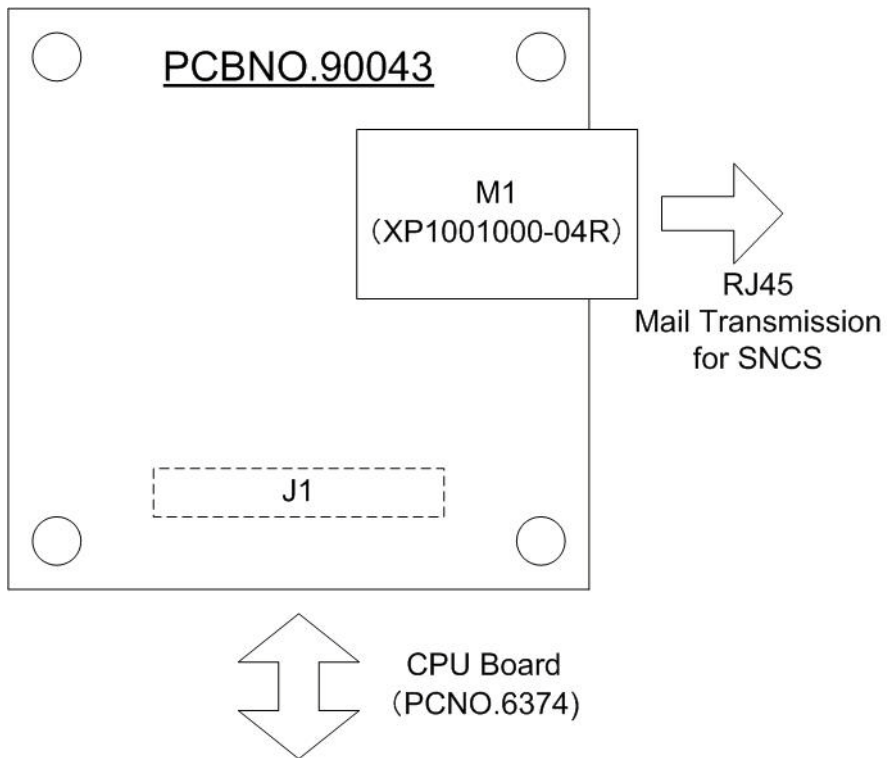

3.7.4 Assignment of connector pin

<J1> (Solenoid valve 1)

Connector : Connector : FX8C-100P-SV6 (HIROSE)

Pin	Signal	Pin	Signal
1	GND	51	GND
2	3.3 V	52	3.3 V
3	5 V	53	5 V
4	TXD2	54	RXD2
5	RTS2	55	CTS2
6	---	56	GND
7	---	57	---
8	---	58	---
9	---	59	---
10	---	60	---
11	---	61	---
12	---	62	---
13	---	63	---
14	GND	64	GND
15	---	65	---
16	---	66	---
17	---	67	---
18	---	68	---
19	---	69	---
20	---	70	---
21	GND	71	GND
22	---	72	---
23	---	73	---
24	---	74	---
25	---	75	---
26	---	76	---
27	GND	77	GND
28	---	78	---
29	---	79	---
30	---	80	---
31	---	81	---
32	---	82	---
33	---	83	---
34	---	84	---
35	---	85	---
36	GND	86	GND
37	---	87	---
38	---	88	---
39	---	89	---
40	---	90	---
41	---	91	---
42	---	92	---
43	---	93	---
44	---	94	---
45	GND	95	GND
46	---	96	---
47	---	97	---
48	5 V	98	5 V
49	3.3 V	99	3.3 V
50	GND	100	GND

3.8 Power Supply Unit (PCB NO.4087T1)

3.8.1 Function

The unit has two type of power supplies for 100-V and 200-V groups of AC lines for different global markets. As the connector on the primary side of the transformer can be used as voltage selector, select appropriate voltage level in conformity with specification of each market.

Configuration of Power Supply Unit is as follows.

- AC Inlet
- Fuse holder
- Power switch
- Noise filter
- Power trans
- Power supply board (PCB NO.4087T1)
- Switching Regulators (LFA100F-12-J1Y)

	AY086732	POWERSUPPLY_ASSY NO.115(JPN/100V)
	CD136144	NOISEFILTER_ASSY NO.2(100V)
	26650113	FUSE 250V4A ST4-4A-N1 (N.AMER)
	26637021	FUSE HOLDER 4303-2901 (N.AMER)
	CA878955	TRANSFORMER POWER PT-114
	BU291768	POWERSUPPLY_ASSY NO.115(EXP/120V)
	BN671730	NOISEFILTER_ASSY NO.2(120V)
	26650113	FUSE 250V4A ST4-4A-N1 (N.AMER)
	26637021	FUSE HOLDER 4303-2901 (N.AMER)
	CA878955	TRANSFORMER POWER PT-114
	AJ787188	POWERSUPPLY_ASSY NO.115(CHN/220V)
	CC069195	NOISEFILTER_ASSY NO.2(220V)
	AX880901	FUSE 50T032H
	26637017	FUSE HOLDER 4303-2401 (EURO+UK)
	CS177111	TRANSFORMER POWER PT-115
	CF438275	POWERSUPPLY_ASSY NO.115(EU/230V)
	CR905019	NOISEFILTER_ASSY NO.2(230V)
	AX880901	FUSE 50T032H
	26637017	FUSE HOLDER 4303-2401 (EURO+UK)
	CS177111	TRANSFORMER POWER PT-115
	AH239055	POWERSUPPLY_ASSY NO.115(UK/240V)
	BS442303	NOISEFILTER_ASSY NO.2(240V)
	AX880901	FUSE 50T032H
	26637017	FUSE HOLDER 4303-2401 (EURO+UK)
	CS177111	TRANSFORMER POWER PT-115

3.8.2 Description

- (1) Power Input
 Input Voltage 100-V group: 100 V, 120 V
 200-V group: 220 V, 230 V, 240 V
 Frequency 50 Hz/60 Hz

- (2) Power Consumption
 Max : 200 VA

- (3) Power Output

Rated Voltage	Average Current	Peak Current	Application
+ 15VDC - 15VDC	0.5 A 0.4 A	0.7 A 0.5 A	Analog circuits and analog V Analog circuits
100VDC	10 mA	20 mA	Constant-current supply
100VAC	10 mA	20 mA	Clog removal
+ 12DCV	2.0 A	2.8 A	Solenoid valve, motor, LCD backlight
100VAC	1.2 A	1.2 A	Pneumatic unit drive

* Output specification above are guaranteed at an ambient temperature below 60°C.

- (4) Power supply type and Performance

Voltage	Type	Constant Voltage Accuracy	Load Regulation	Ripple Voltage
+ 15 VDC	Series	±0.75 V	2 %	15 mV max.
- 15 VDC	Series	±0.75 V	2 %	15 mV max.
100 VDC	Series	±3 V	2 %	10 mV max.
+ 12 VDC	Switching	±0.2 V	2 %	150 mV max.
100 VAC	Transformer output	-	-	-

- (5) Dimensions and weight
 Dimensions W x D x H = 215 x 235 x 120
 Weight Approx. 5.2kg

- (6) Power Transformer

Primary side input voltage	AC100 V, 120 V, 220 V, 230 V, 240 V
Secondary side input voltage	AC108 V, 100V, 102 V, 16.5 V - 0 - 16.5 V
Capacity	150 VA
Insulation	Type A
Dimension	W x D x H = 140 x 115 x 75
Weight	Approx. 3.8 kg

(7) Fuses

PCB NO. 4087T1 A

Circuit Symbol	PS code	Part Name
F1	AF208615	FUSE 37405000410 0.5A
F2, 3	BF752335	FUSE 37411600410 1.6A
F5	AY775445	FUSE 37400500410 0.05A
F6	BU624205	FUSE 37414000410 4A

AC inlet

Circuit Symbol	PS code	Part Name
100/200 V groups	26636757	AC INLET KD14.1101.151

(8) Voltage Selection

Connect the Wiring Cord NO.2370 as below according to the required voltage.

- 1) 120 V
Pin 1 (light blue) and Pin 3 (brown)
- 2) 220 V
Pin 1 (light blue) and Pin 4 (brown)
- 3) 230 V
Pin 1 (light blue) and Pin 5 (brown)
- 4) 240 V
Pin 1 (light blue) and Pin 6 (brown)

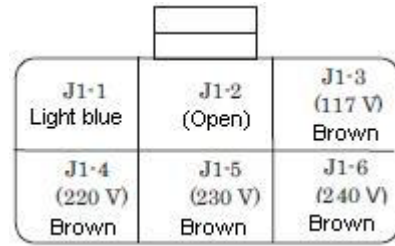

Wiring at Connector J1

A 201297

3.8.3

Block Diagram

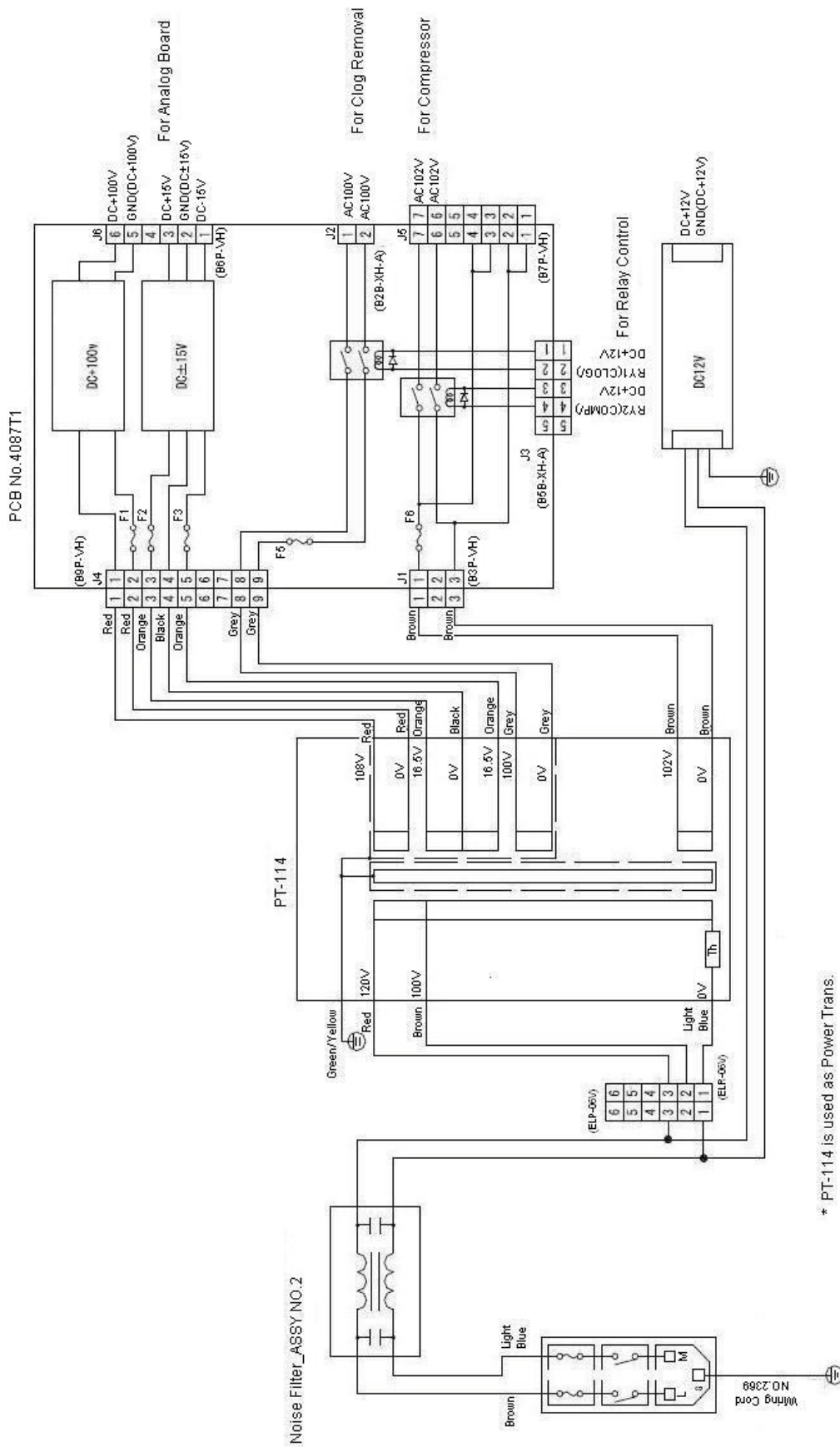

* PT-114 is used as Power Trans.

Power Supply Unit (for 100V-Group) Block Diagram

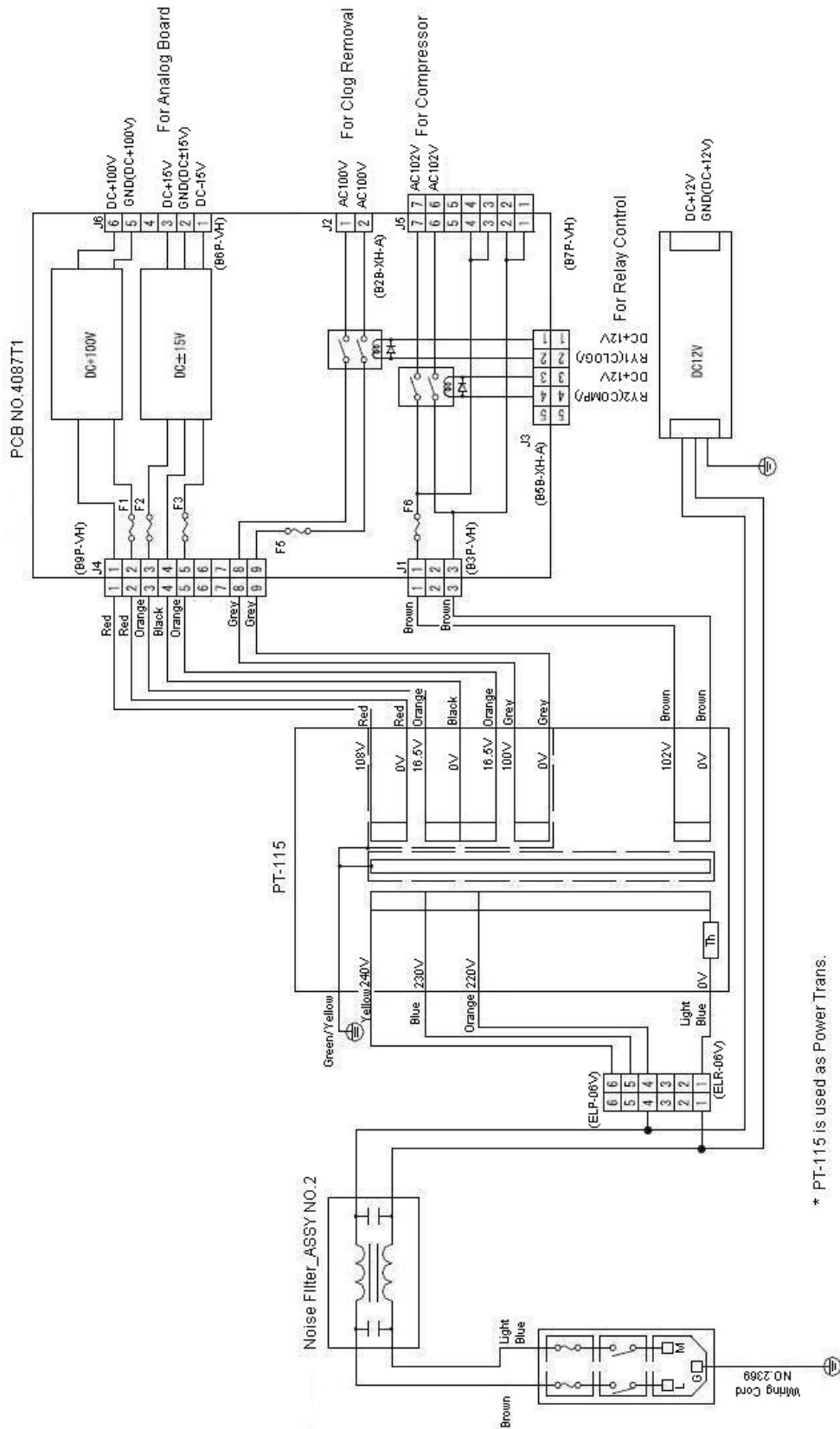

* PT-115 is used as Power Trans.

Power Supply Unit (for 200V-Group) Block Diagram

CHAPTER 4 ADJUSTMENT

4.1 STANDARD SENSITIVITY ADJUSTMENT	1
4.1.1 WBC and RBC Sensitivity Adjustment.....	1
4.1.2 PLT Sensitivity Adjustment	7
4.2 HGB ADJUSTMENT.....	10
4.3 CLOG LEVEL ADJUSTMENT	12
4.4 PCB CHECKING AND ADJUSTMENT	14
4.4.1 PCB NO.20034/PCB No. 2135	14
4.4.2 PCB No. 6374 (CPU).....	14
4.4.3 PCB No. 4087 (Power Supply)	16
4.5 Mechanical Parts Adjustment	17
4.5.1 SRV Position Adjustment.....	17
4.5.2 Rinse Cup Position Adjustment	19

CHAPTER 4 ADJUSTMENT

4.1 STANDARD SENSITIVITY ADJUSTMENT

<NOTE>

Do not disconnect J3 (Wiring Cord No.2363) and J4 (Wiring Cord No.2364) while performing Standard Sensitivity Adjustment). If the wiring cord is disconnected while the power on, the PCB will be damaged. When disconnecting the connection of the wiring cords to confirm the connection status, turn off the instrument first.

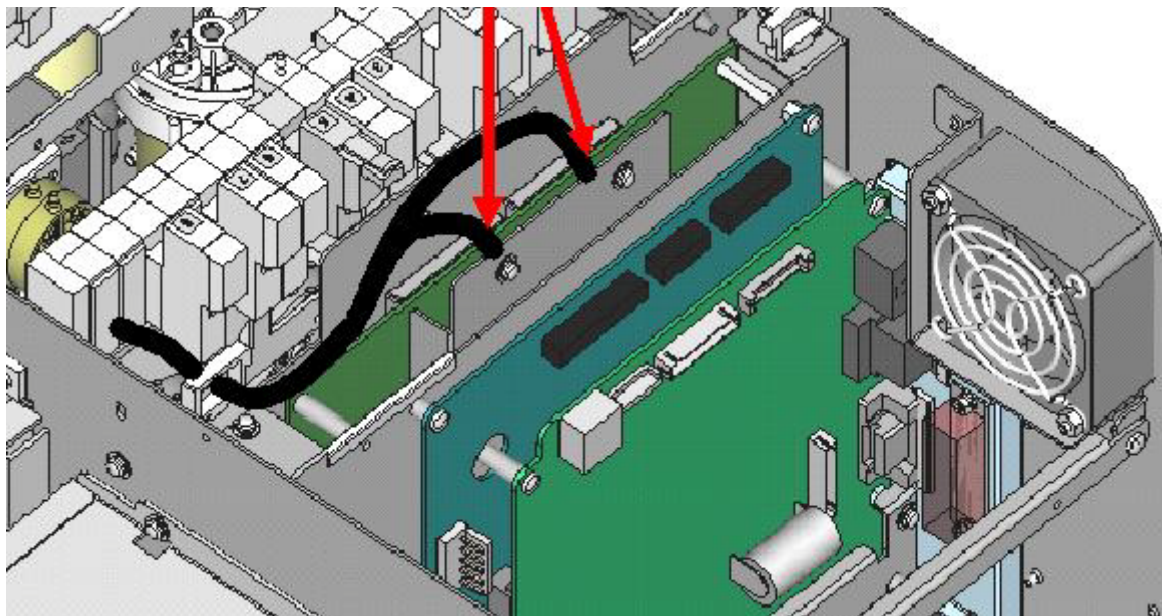

4.1.1 WBC and RBC Sensitivity Adjustment

Required reagent CELLCHECK-400 (P/N: 814-0012-9)

- (1) Verify that the temperature of CELLPACK and the room temperature is within the range of 15 - 30°C.
- (2) Enter the Service mode. (Enter C, 9, -, 0 into the sample number input box.) Hot start is also can be enter the service mode.)
- (3) Press the Start Switch and verify WBC and RBC background counts fall into the ranges below:
WBC background value $0.30 \times 10^3/\mu\text{L}$
RBC background value $0.30 \times 10^4/\mu\text{L}$

- (4) Select menu > Service > Service Seq. > Gain Adjustment > WBC/RBC.

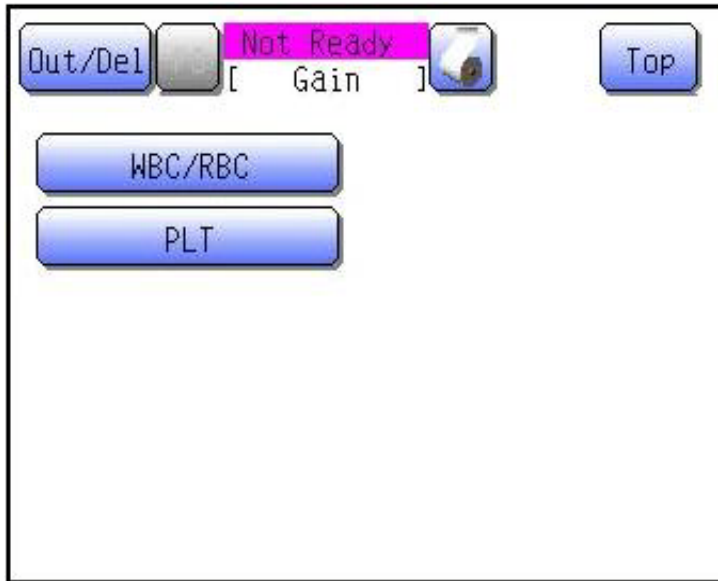

- (5) Pre-process for automatic sensitivity adjustment sequence starts.

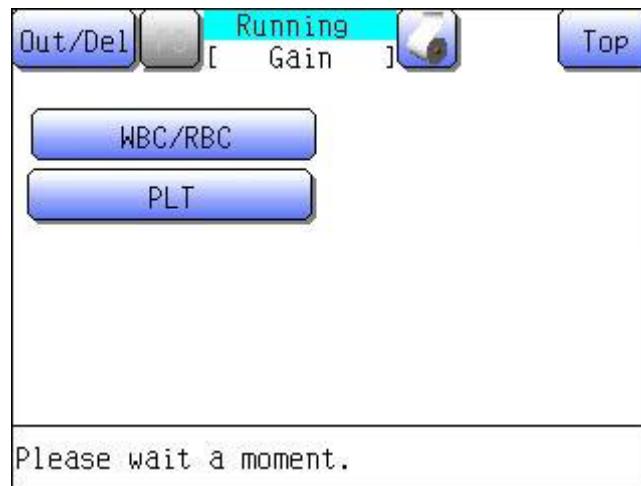
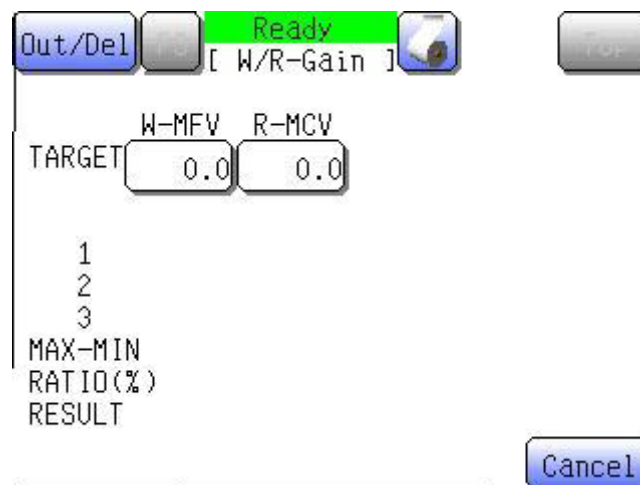

Figure 4-1-1:WBC/RBC Gain Adjustment Display

- (6) After completing pre-sequence, Gain Adjustment screen appears.



TARGET Area for entering the target value
 1, 2, 3 Area that displays the 3 analysis values
 MAX-MIN Area that displays the difference between the maximum and minimum of the 3 analysis values.
 RATIO(%) Area that displays the calculated compensation ratio Area that displays the analysis values after they are compensated

(7) Enter the TARGET values using the numeric and decimal keys.

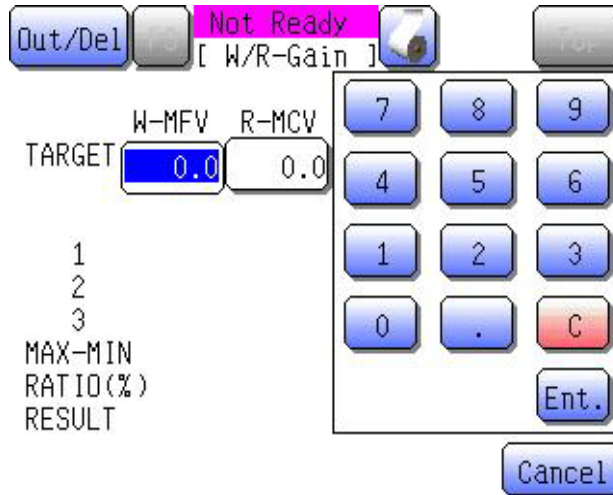

When the Gain Adjustment screen appears, W-MFV target box will be reversed. Enter the target value.

Parameter	Target value	CELLCHECK-400 Lot No.
W-MFV	188.0 +/- 2.0 fL	A1003 - A3005
W-MFV	180.5 +/- 2.0 fL A TB201379	A3006 and thereafter
R-MCV	1.26 x (Assay value MCV of CELLCHECK-400/CC-108)	-

- (8) Open the Detector Cover by loosening the fixing screw.
- (9) Mix CELLCHECK-400 ampules vigorously, and pour it into the DB-1 sample beaker.

- (10) Pour approx. 3.5 mL of CELLCHECK-400 into the WBC transducer chamber and approx. 2.5 mL into the RBC transducer chamber.

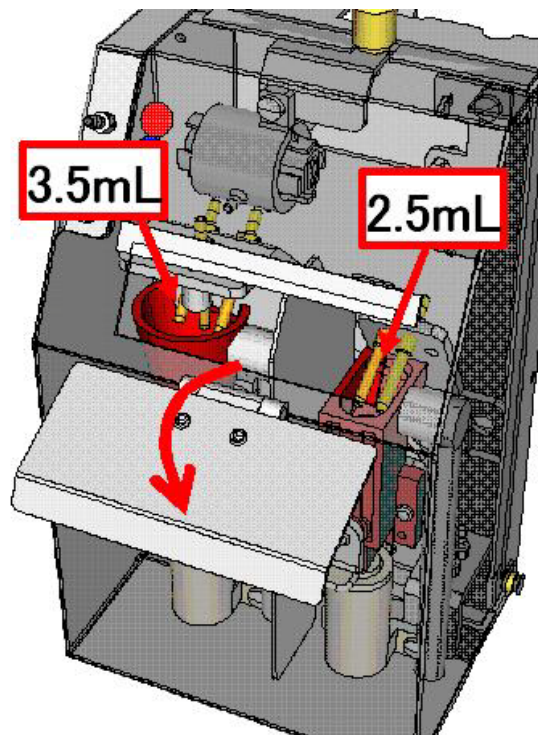

- (11) Close the Detector Cover, and press the Start Switch.

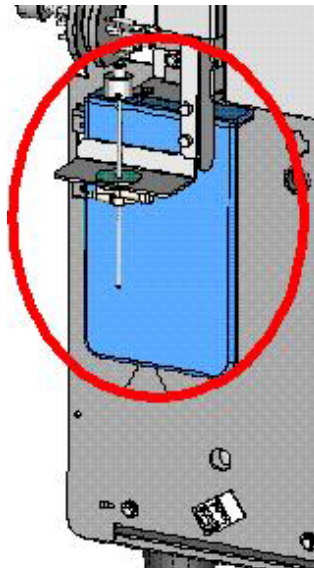

- (12) The recount analysis sequence will be performed automatically three times and the three analysis values (1 to 3), difference between the maximum and minimum (MAX-MIN), and compensation ratio (RATIO%) will be calculated. (For approximately 2 minutes.)

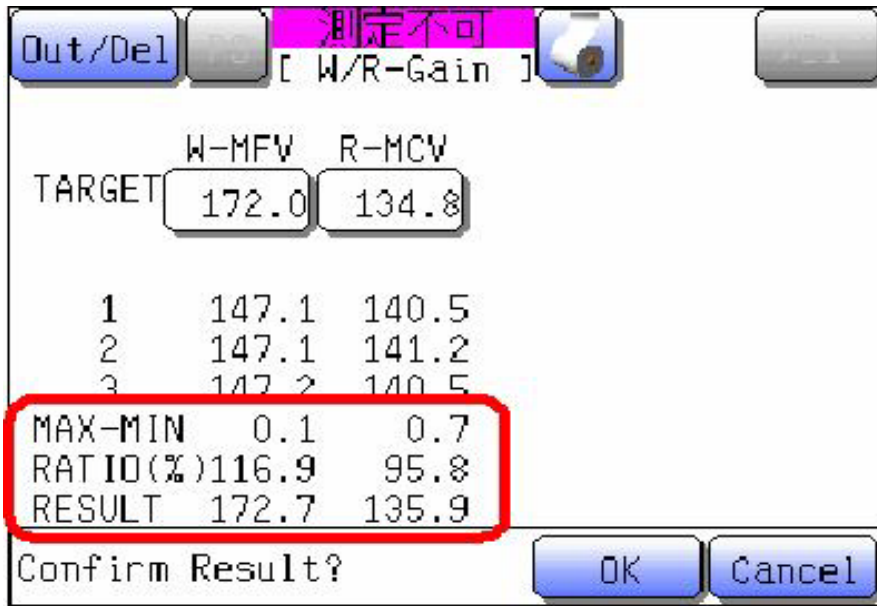

Figure 4-1-3 WBC/RBC Gain Adjustment Display

(13) Analysis is performed once again and displays the analysis values (RESULT).

Verify that the followings are all satisfied. (W-MFV, R-MCV)

[W-MFV] Δ TB201379

MAX-MIN ≤ 4 [fl]

RATIO(%) = 100 ± 50

RESULT = Target ± 2 [fl]

[R-MCV]

MAX-MIN ≤ 4 [fl]

RATIO(%) = 100 ± 50

RESULT = Target ± 2 [fl]

(14) Click [OK] when the analysis values (RESULT) satisfy the standard values. The gain adjustment value will be updated and the system will return to the Ready Screen.

(15) If the result is not satisfied with target ± 2 fL, calculate new target value as follows.

New Target value = (TARGET) 2 / Result (Round off below decimal)

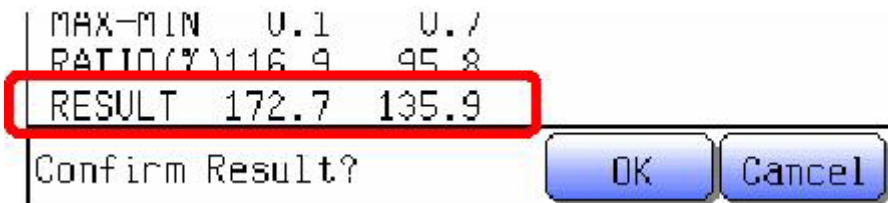

(16) Click Cancel enter the new target value in target M-MFV or R-MCV and perform sensitivity adjustment again.

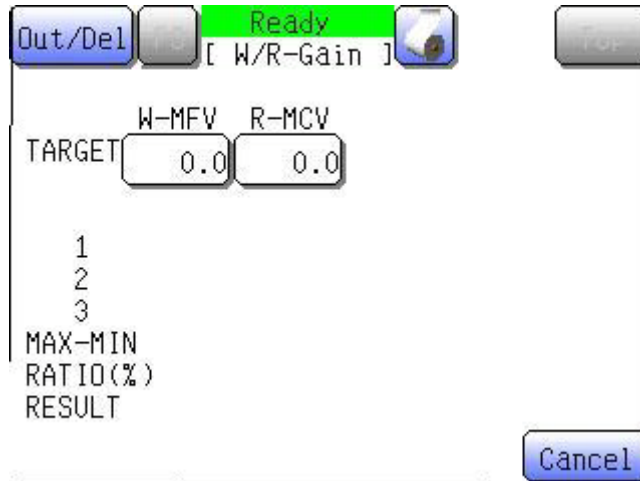

(17) After completing adjustment, "Confirm Result?" appears, click OK.

4.1.2 PLT Sensitivity Adjustment

Required reagent LATEX CALIBRATOR PLT (E); Part No. 951-0222-1 (Or diluted in 1: 55 with CELLSHEATH 8LTX4203A_3.0MICRONS/15ML_3.063 P/N: 66645267 with assay value.)

- (1) Verify that the temperature of CELLPACK and the room temperature is within the range of 15 - 30°C.
- (2) Remove the Top Cover Remove the Shield Cover No. 224 by loosening four fixing screw M3x8 (SUS).

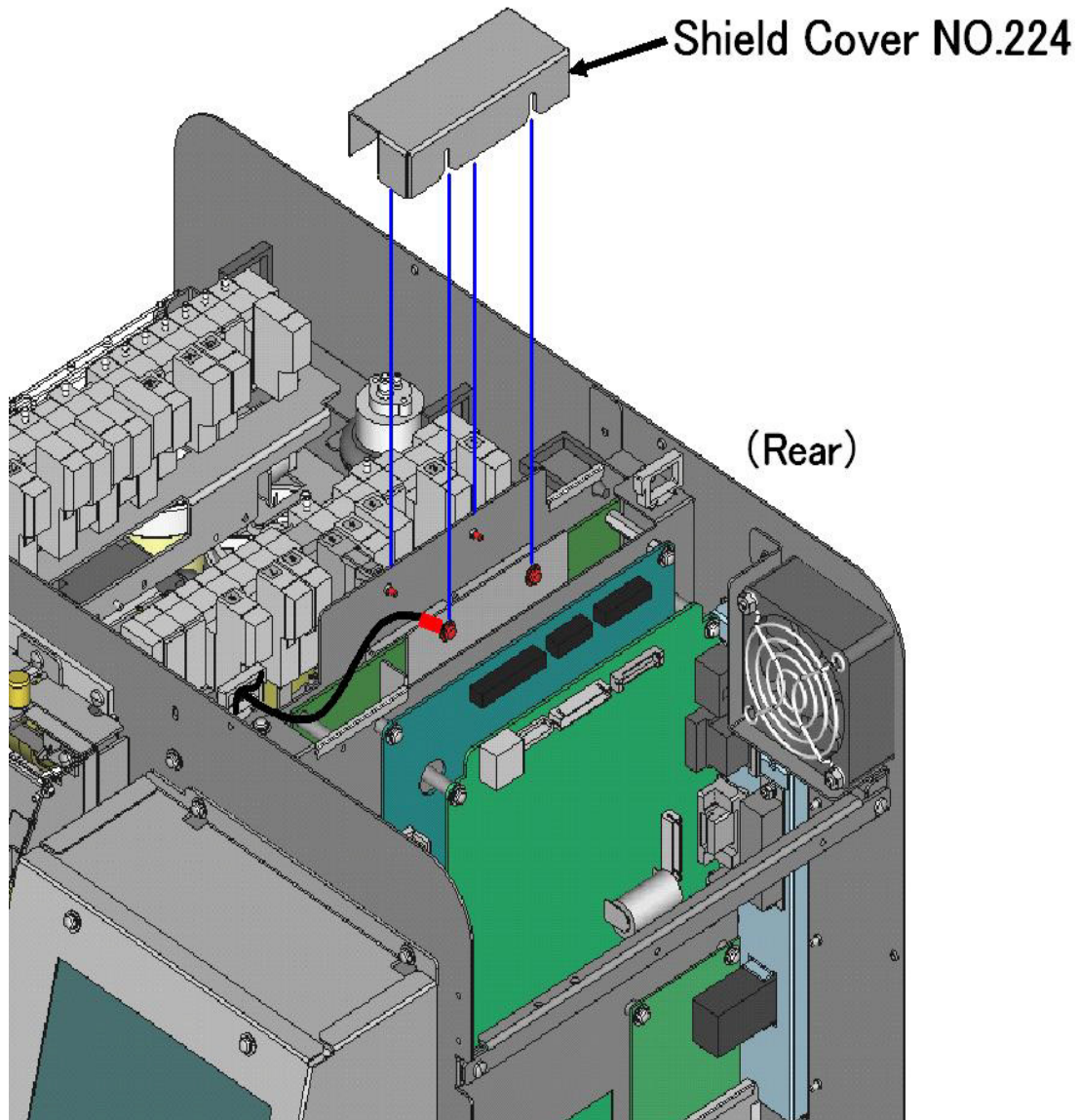

- (3) Enter the Service mode. (Enter C, 9, -, 0 into the sample number input box.) Hot start is also can be enter the service mode.)
- (4) Press the Start Switch and verify PLT background counts fall into the ranges below.
PLT background value $\leq 0.30 \times 10^4/\mu\text{L}$

- (5) elect menu > Service > Service Seq. > Gain Adjustment > PLT.

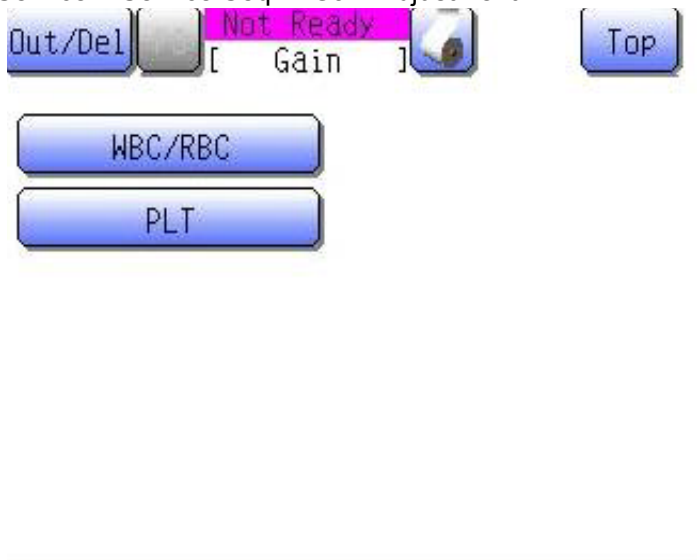

Figure 4-1-4: PLT Gain Adjustment Display

- (6) Mix the PLT Latex Calibrator by gently swirling vial. Set the Latex Calibrator at the aspiration pipette and press the Start Switch to aspirate it.
- (7) When the analysis is completed, the P-MFV result will be displayed.



Figure 4-1-5: Displayed the 1st Result of P-MFV

- (8) Adjust the VR5 on PCB NO.20034 (XP/KX) [P/N: AG620580]/ PCB No. 2135 (KX-21)/No. 2150 (KX-21N) so that the P-MFV falls within the acceptable range below. A

Turning the VR clockwise will increase the value.

$$\text{P-MFV} = (\text{Target MFV value provided for each LATEX CALIBRATOR PLT (PM/C2)}) \pm 0.2.$$

A 312J003

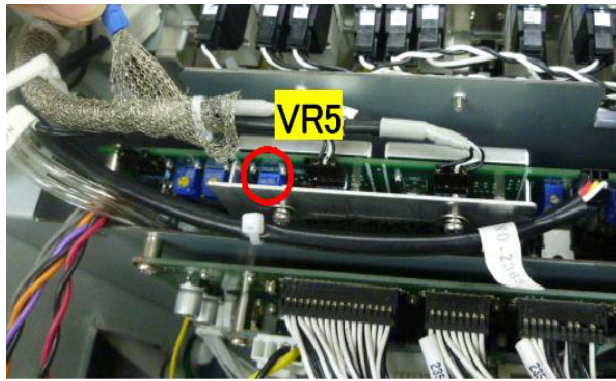

Figure 4-1-6: VR5 on PCB NO.20034/PCB No. 2135 A

- (9) Press the Start Switch to recount the Latex Calibrator.
Run the recount sequence and VR adjustment three times in total.
- (10) After the 4th analysis (recounting) is completed, press [Cont] key to continue the Latex analyses again.
- (11) Repeat the steps (7) through (9) above until the P-MFV falls into the acceptable range.
- (12) After the adjustment is completed, obtain three P-MFV results by analyzing or recounting Latex Calibrator.
- (13) Calculate the average of the three results and verify that the average falls within the acceptable range. If the result is not satisfied the acceptable range, adjustment should be performed again/
Acceptable range=Target MFV value provided for each LATEX CALIBRATOR PLT (PM/C2) ± 0.2
- (14) Press [OK] key to exit the adjustment program.
- (15) Refit the Shield Cover No. 224 and the Top Cover.

A 312J003

4.2 HGB ADJUSTMENT

- (1) Confirm that 30 minutes past after turning on the main unit.
- (2) Select Menu > (Maintenance) > (Status Display) to display status display.

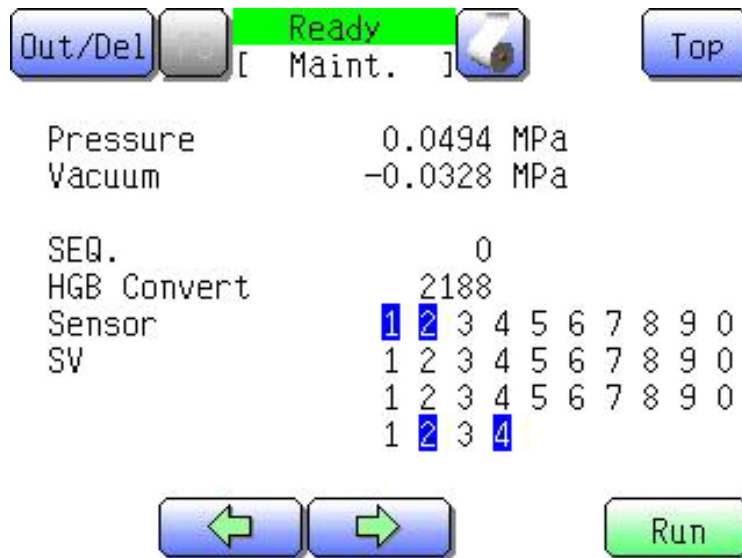

Figure 4-2-1: Status Display

- (3) Adjust the VR1 on the PCB NO.20034 (XP/KX) [P/N: AG620580]/ PCB No. 2135 (KX-21) so that the HGB CONVERT value falls within the range 2000±200. **B**

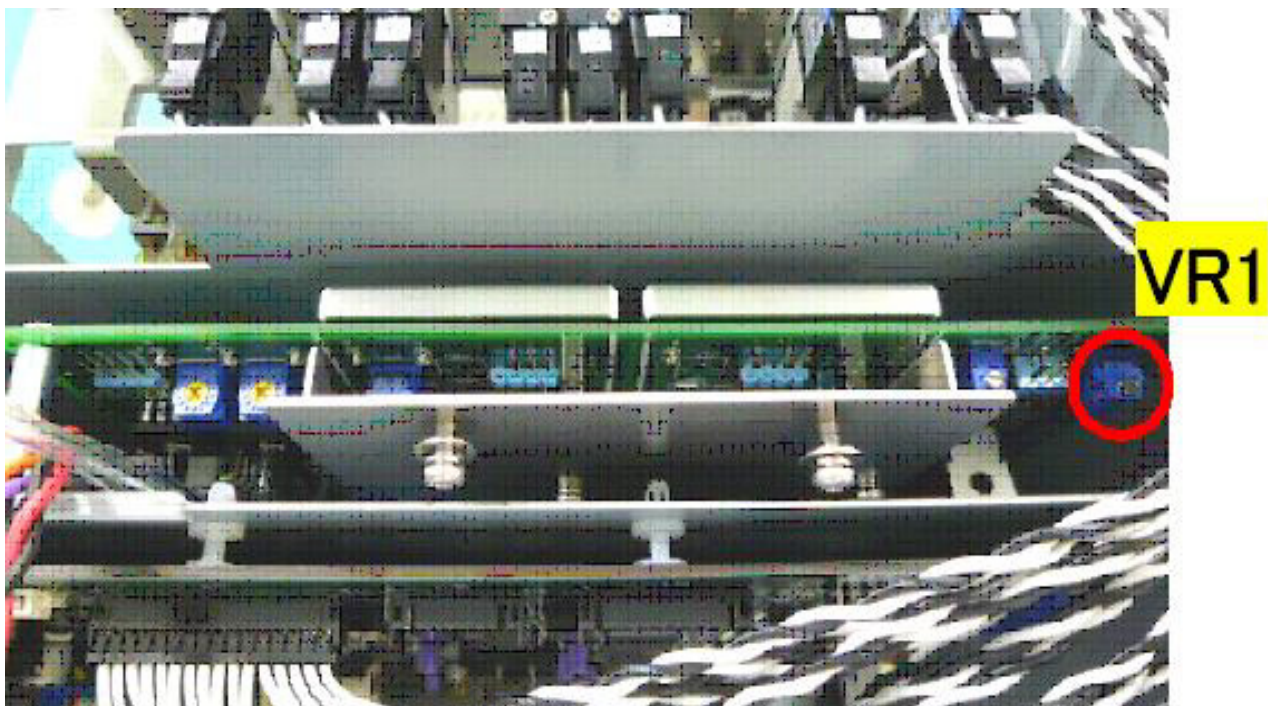

Figure 4-2-2: VRs for HGB Adjustment

- (4) Press "Run" key on the LCD to aspirate the fresh Sysmex control blood EIGHTCHECK (Normal Level). **A**

A 201297 **B** 312J003

- (5) Press [Stop] key to stop the sequence at Sequence 7.

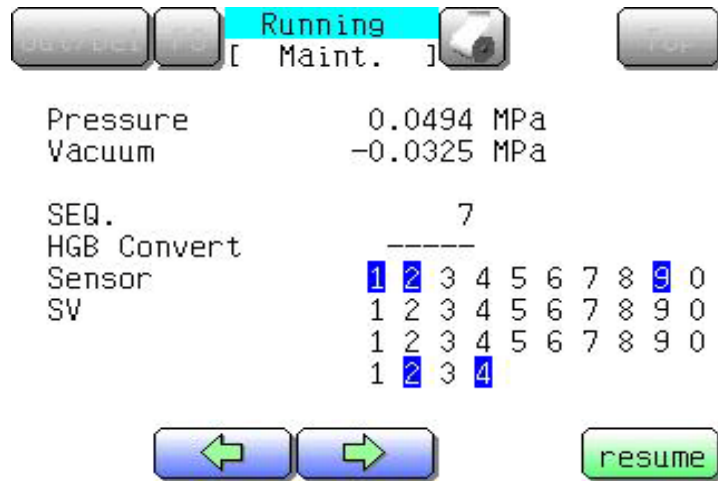

Figure 4-2-3: Sequence Stop at Sequence 7

- (6) Adjust the VR2 on the PCB NO.20034 (XP/KX) [P/N: AG620580]/PCB No. 2135 (KX-21) so that the HGB CONVERT value falls within the following range:

$$\text{HGB CONVERT} = (\text{HGB Assay Value for EIGHTCHECK}) \pm 0.5 \text{ [g/dL]} \quad \text{A}$$

- (7) Press [Resume] key to resume the sequence.
- (8) Confirm that the HGB Convert value is within the range below after screen turns to ready status. If the value is out of the range, adjust the VR1 on PCB NO.20034 (XP/KX) [P/N: AG620580]/PCB No. 2135 so that HGB Convert value is within the range below.

HGB Convert Value = 2000±200 A

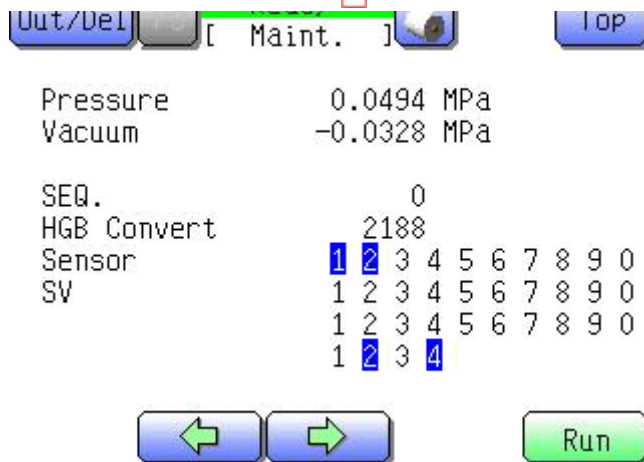

A 312J003

4.3 CLOG LEVEL ADJUSTMENT

(1) Select menu > Service > Service Seq. > Clog Adjustment. Select WBC.

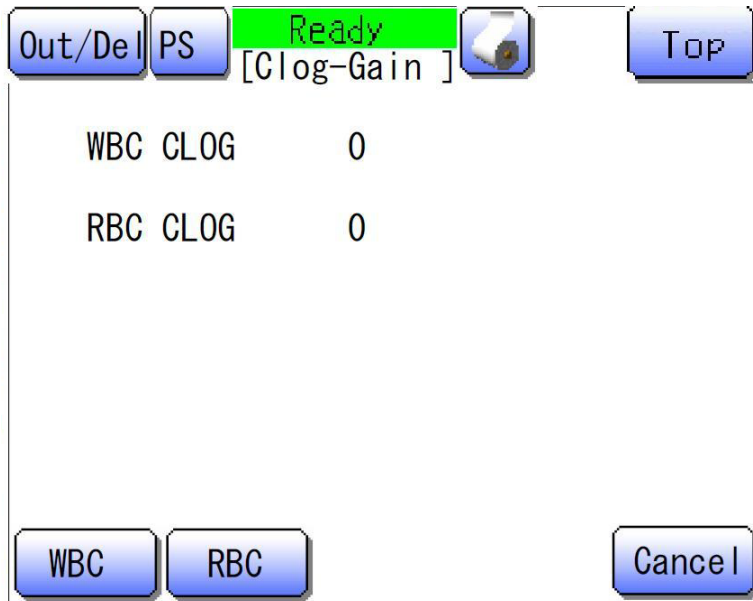

(2) When below screen appears, Adjust the VR6 on the PCB NO.20034 (XP/KX) [P/N: AG620580]/ PCB No. 2135 (KX-21) so that the WBC clog level falls within the following range.

WBC Clog value: 100.0 ± 1.0

The system returns to the Ready screen in 30 seconds. If the adjustment has not been completed when the system returns to Ready status, select WBC again. A

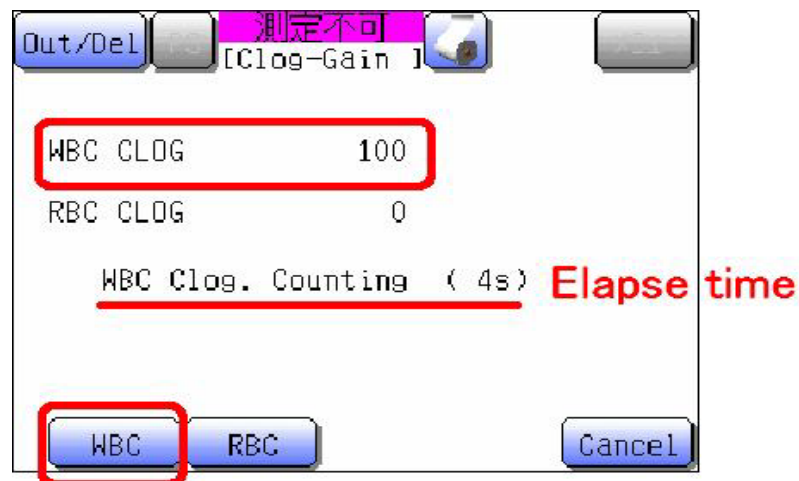
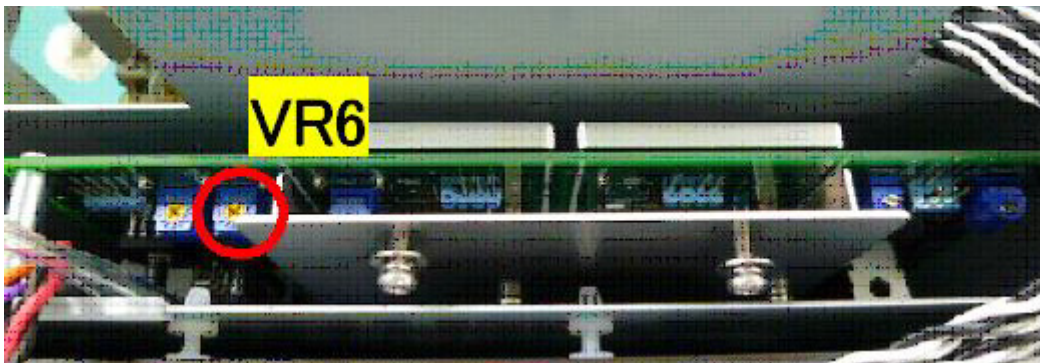

Figure 4-3-1: Clog Adjustment Screen

A 312J003



- (3) In the same manner, adjust the VR7 on the PCB NO.20034 (XP/KX) [P/N: AG620580]/PCB No. 2135 (KX-21) so that the RBC clog level falls within the following range.

RBC Clog: 100.0 ± 1.0 A

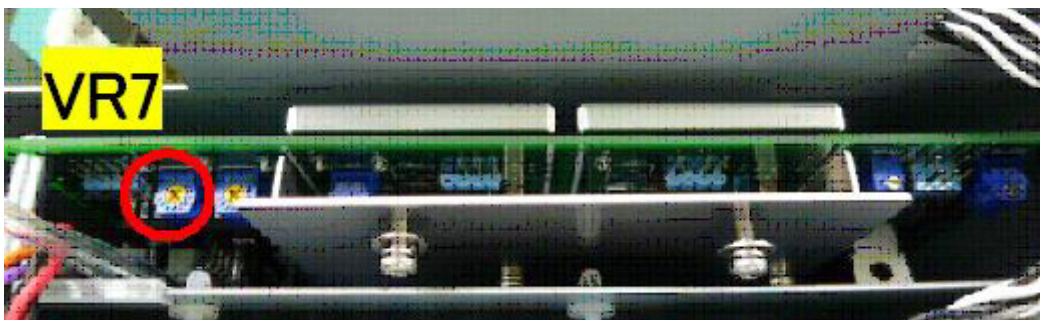

Figure 4-3-2: CLOG LEVEL ADJUSTMENT

- (4) The system returns to the Ready screen in 30 seconds.
If the adjustment has not been completed when the system returns to Ready status, select RBC again.

A 312J003

4.4 PCB CHECKING AND ADJUSTMENT

4.4.1 PCB NO.20034/PCB No. 2135 A

- (1) HGB circuit adjustment

Adjusting VR	Parameter to be adjusted
VR1	Coarse BLANK adjustment
VR2	Coarse GAIN adjustment

- (2) Clog monitoring circuit adjustment

Adjusting VR	Test Points	Parameter to be adjusted
VR7	TP13	RBC, PLT
VR6	TP12	WBC

- (3) Sensitivity Adjustment

PCB NO.20034 (XP/KX) [P/N: AG620580]/PCB No. 2135/No.2150 uses digital VRs to adjust RBC and WBC sensitivity. PLT sensitivity is adjusted by a conventional variable VR. Refer to PLT Sensitivity Adjustment. A

- (4) Test Points

TP8	WBC Sensitivity
TP9	RBC Sensitivity
TP10	PLT Sensitivity
TP11	GND (Analog)
TP12	WBC Clog Monitoring Signal
TP13	RBC Clog Monitoring Signal

4.4.2 PCB No. 6374 (CPU)

- (1) DIP Switch S1 Settings

SW	Setting Parameters	Description
S1	DIP Switch	Bit 1: OFF, Bit 2 -8: ON (Fixed)
S2	Reset	Microcomputer Reset is triggered when lever is pressed.
S3	Printer Port	Fixed in IN side.

A 312J003

(2) LED

LED	Item	Description
D1	POWER	ON: Power is supplied. OFF: Power is not supplied.
D6	RUN	ON: CPU under CPU operation. OFF: Under CPU Reset Process
D7	FL BSY	ON: under Writing on Flash Memory/ Deletion OFF: Normal Operation.
D8	B START	Flashing: Outside bus cycle is operating. ON/OFF: Inside unit access or HALT
D11	LINK	ON: Connected to network. OFF: Not connected to network.
D12	RD	Flashing: Packet being received. OFF: Packet not being received.
D13	TD	Flashing: Packet being sent. OFF: Packet not being sent.

(3) Test Points

TP	Item	TP	Description
TP1	5V (5V for logic)	TP7	PGND (GND for 8V)
TP2	G12 (GND for 12V)	TP8	1.9V (1.9V for logic)
TP3	GND (GND for logic)	TP9	I-RST (RESET input terminal for ICE)
TP4	12V (12V Power Input)	TP10	33MHz (bus clock)
TP5	3.3V (3.3V for logic)	TP11	1Hz (terminal for calendar operation check)
TP6	(8V for embedded printer)		

Note) Adjustment volume for LCD contrast is located at the bottom of Panel Keyboard.

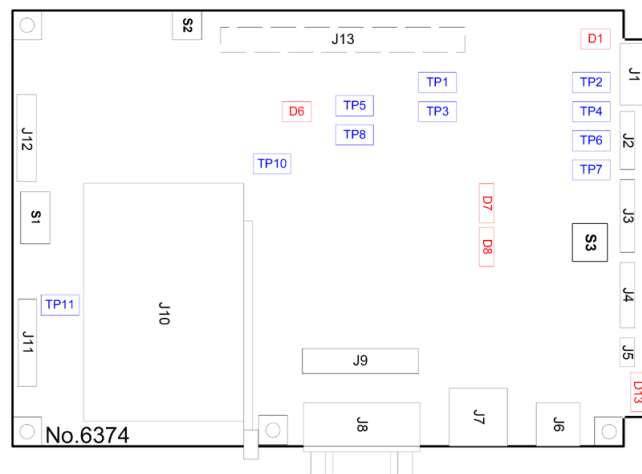

Figure 4-4-1: CPU PCB

(4) Note for replacing PCB No. 6374 (CPU)

(1) Data Moving

Analysis results or set values are stored in BBURAM. Record by printing these values before replacing PCB, then manually enter them after replacing the PCB.

(2) Switch Setting Check

Confirm that the Bit 1 is OFF, Bit 2 through 8 are ON and printer port mode switch S3 is "IN."

(These values are default setting. Normally, checking the setting values in only necessary.)

4.4.3 PCB No. 4087 (Power Supply)

1) PCBNO.4087T1

Adjusting VR	Adjustment Voltage	Test Points
VR1	DC+100V ± 3V	J6 - 5 (GND) J6 - 6 (DC+100V)

2) Switching Regulator LFA100F-12-j1Y

Adjusting VR	Adjustment Voltage	Test Points
VR1	DC+12V ± 0.2V	CN2 - 1?4 (GND) CN2 - 5?8 (DC+12V)

4.5 Mechanical Parts Adjustment

4.5.1 SRV Position Adjustment

- (1) Enter the Service mode. (Refer to Chapter 5 Service Program 5.1.2 Entering Service Mode)
- (2) Select SV/MT Test Operation by selecting Menu > "Service" -> "Test Operation" -> "2: SV Test Operation."

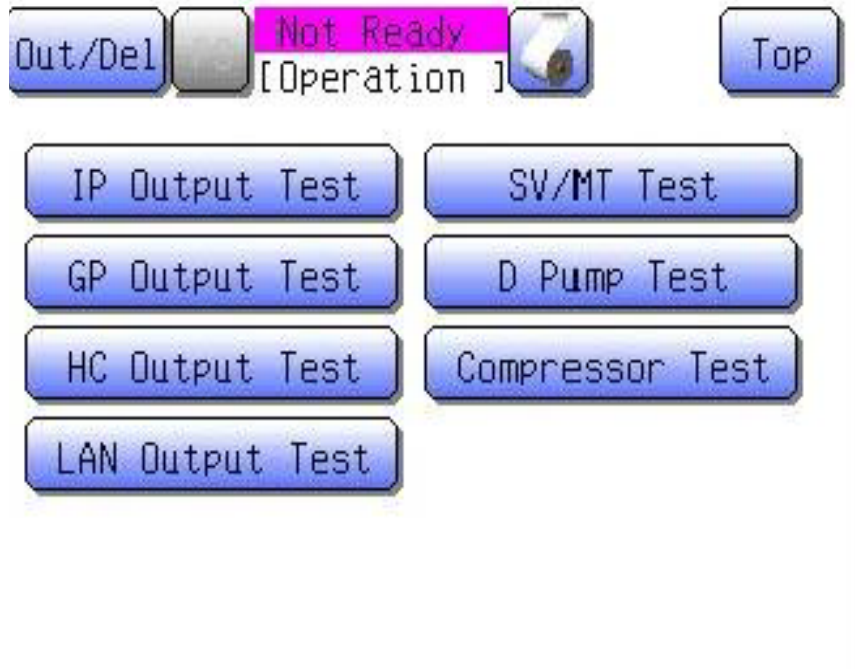

- (3) Prepare a drill bit with 0.8 mm diameter.
- (4) Verify that this drill bit can penetrate through SRV (3 pieces: SRV Fixed Valve (L), Rotor Valve and SRV Fixed Valve (R)) at the SRV alignment hole. If not, adjust the lower Stopper position by loosening a hex-socket fixing screw so that the drill bit will smoothly penetrate through the SRV.

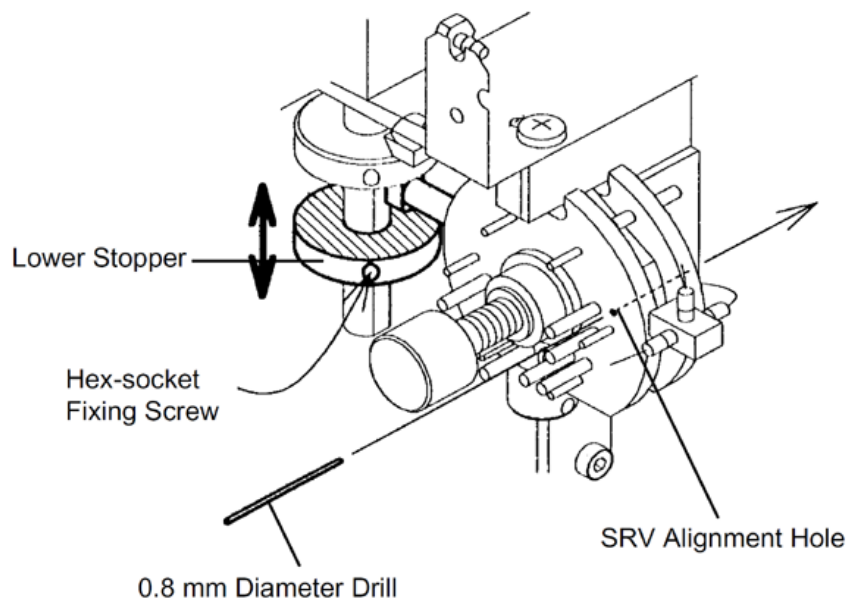

Figure 4-5-1: SRV Position Adjustment (Home Position)

- (5) Rotate the SRV by entering SV No. 16 and ENTER.

Out/Del		Not Ready				Top	
		[SV/MT]					
01	02	03	04	05	06	07	08
09	10	11	12	13	14	15	16
17	18	19	20	21	22	23	24

- (6) Verify that this drill bit can penetrate through SRV (3 pieces: SRV Fixed Valve (L), Rotor Valve and SRV Fixed Valve (R)) at the SRV alignment hole.

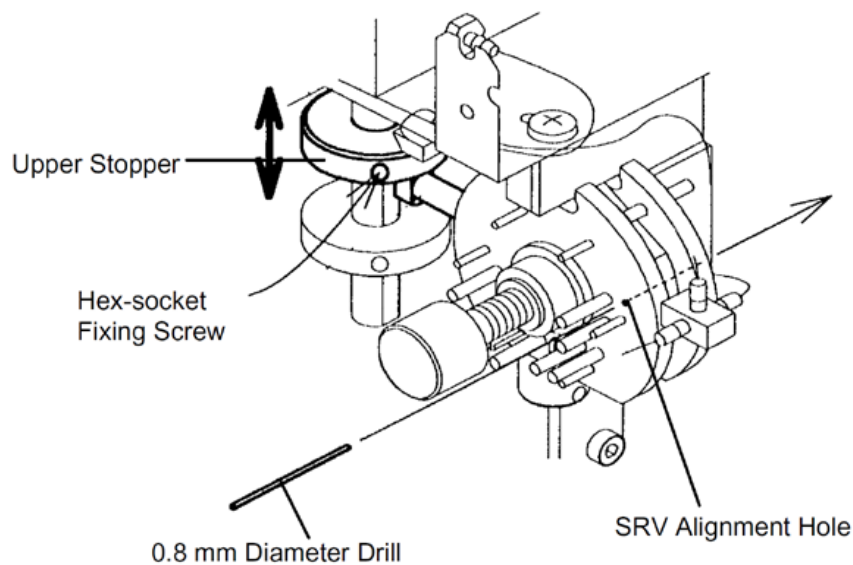
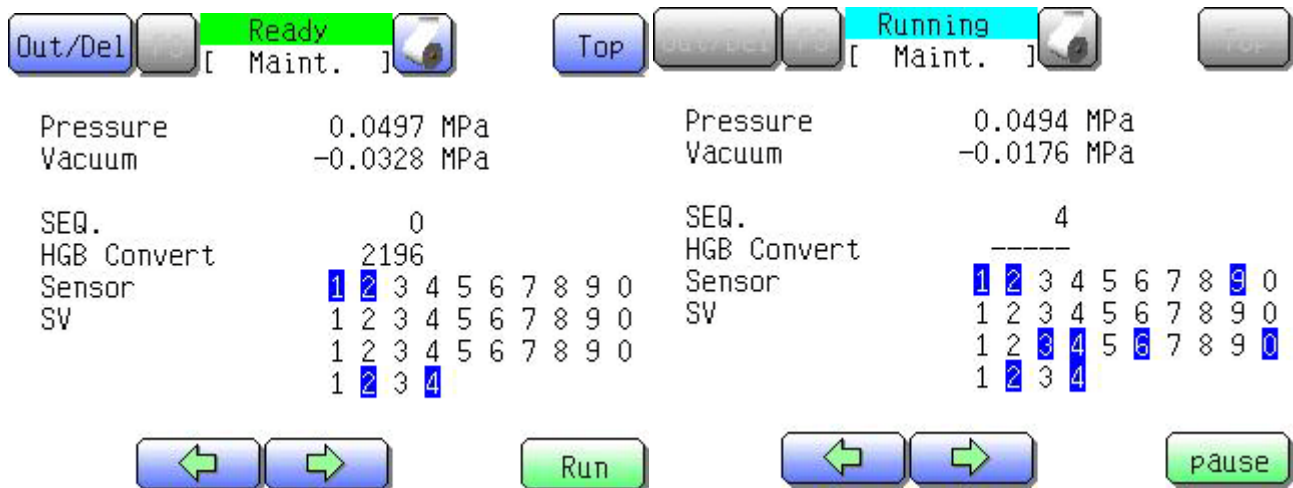

Figure 4-5-2: SRV Position Adjustment (Rotate Position)

- (7) Rotate the SRV to home position by pressing 16 and ENTER again.
- (8) Perform AUTO RINSE and verify that no background count error is reported after rinsing sequence is completed.
- (9) Perform QC and verify that the control blood data is acceptable

4.5.2 Rinse Cup Position Adjustment

- (1) Enter the Service mode. (Refer to Chapter 5 Service Program 5.1.2 Entering Service Mode)
- (2) Select Menu > (Maintenance) > (Status Display) to display status display.
- (3) Click "Run" key and wait until rinse cup descends to the lowest position.
- (4) Press pause key to stop the sequence.



- (5) Verify the pipette tip is placed in the gap "A". (View from "B" is easy to verify.) (View from "B" is easy to verify.)

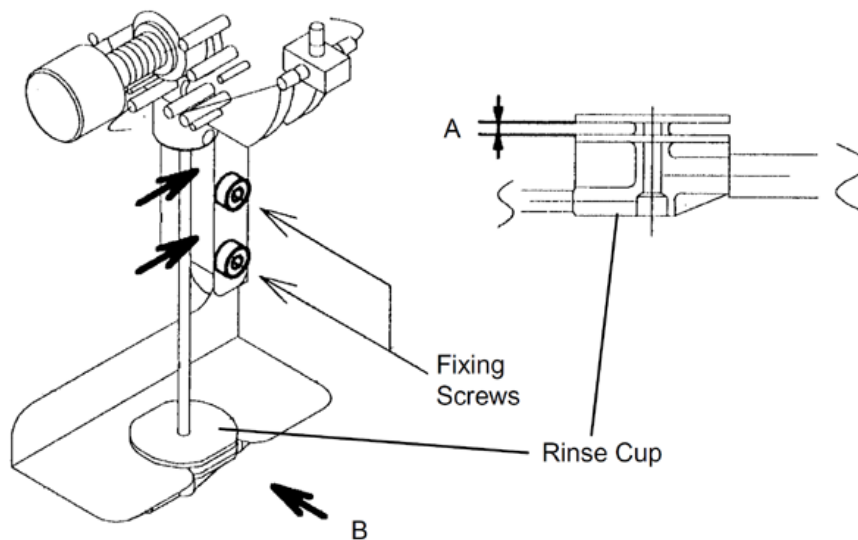

Figure 4-5-3: Rinse Cup Adjustment

- (6) If adjustment is necessary, adjust the Rinse Cup height by loosening two screws shown in figure so that the pipette tip will be between the gap "A."

CHAPTER 5 SERVICE PROGRAM

5.1 Outline	1
5.1.1 Functions.....	1
5.1.2 Entering Service Mode.....	1
5.1.3 Entering Service Mode using Hot Start.....	1
5.1.4 Exiting Service Mode	1
5.2 Service Menu.....	2
5.2.1 Service Menu Screen.....	2
5.2.2 Menu Tree.....	3
5.3 Service Sequence.....	4
5.3.1 Service Sequence Menu	4
5.3.2 Setting Sequence.....	5
5.3.3 Deprime Sequence	6
5.3.4 Gain Adjustment Sequence	7
5.3.4.1 Automatic Gain Adjustment Preparation Sequence (WBC/RBC).....	8
5.3.4.2 Automatic Gain Adjustment Settings Screen (WBC/RBC)	8
5.3.4.3 Canceling Automatic Gain Adjustment.....	9
5.3.4.4 Automatic Gain Adjustment (In Progress) Screen.....	10
5.3.4.5 How to Adjust Gain Automatically	11
5.3.4.6 Confirming Automatic Gain Adjustment Results (WBC/RBC)	12
5.3.4.7 Manual Gain Adjustment Settings Screen (PLT).....	13
5.3.4.8 Cancelling Manual Gain Adjustment	13
5.3.4.9 Manual Gain Adjustment (In Progress) Screen.....	14
5.3.4.10 Confirming Manual Gain Adjustment Results (PLT).....	15
5.3.5 Clog Adjustment (Clog Voltage Adjustment Sequence).....	16
5.3.5.1 Clog Adjustment (In Progress) Screen	17
5.3.6 Control Mode.....	18
5.3.7 Calibrator Mode.....	18
5.3.8 Continuous Mode	18
5.3.9 Clog removal	19
5.3.9.1 “Run Clog Removal” Screen.....	19
5.3.9.2 Clog Removal (In Progress) Screen.....	20
5.4 Settings.....	21
5.4.1 Initialize	22
5.4.1.1 “Confirm Initialization” Dialog Box	23
5.4.1.2 Items to be initialized.....	23
5.4.2 Change.....	24
5.4.2.1 Calibration	24
5.4.2.2 Setting Storing Confirmation Dialog Box	26
5.4.2.3 Setting Cancel Confirmation Dialog Box	26
5.4.2.4 Hardware Limit	27
5.4.2.5 Analysis Limit	29
5.4.2.6 Parameters	31
5.4.2.7 Report Item.....	34

5.4.3 Print Settings	34
5.5 Test Operation	35
5.5.1 SV/MT Test Operation	36
5.5.2 D Pump Test	36
5.5.3 HC Output Test	37
5.5.4 LAN Output Test	37
5.5.5 IP Output Test	37
5.5.6 GP Output Test	37
5.5.7 Compressor Test.....	37
5.6 Product Settings	38
5.6.1 Setting Storing Confirmation Dialog Box.....	39
5.6.2 Setting Cancel Dialog Box	40
5.7 BBU Backup	41
5.7.1 BBU RAM Backup Confirmation Dialog Box.....	41
5.7.2 BBU Backup Error Dialog Box	42
5.8 BBU Restore.....	43
5.8.1 BBU Restoration Confirmation Dialog Box.....	43
5.8.2 "Restoration Error" Dialog Box.....	44
5.8.3 "Check Sum Error" Dialog Box.....	44
5.8.4 "Restoration completed" Screen	45
5.8.5 Settings Backup (Reference).....	45
5.9 SNCS Settings.....	47
5.9.1 SNCS Settings Screen.....	47
5.9.2 SNCS Connection Settings Screen (When [Connect Settings] button is pressed).....	48
5.9.3 SNCS Network Settings Selection Screen (When [Network Settings] is pressed)	49
5.9.4 SNCS Network Settings Screen.....	50
5.9.5 SNCS Network Individual Settings Screen	55
5.9.6 Setting Cancel Confirmation Dialog Box.....	55
5.9.7 Setting Storing Confirmation Dialog Box.....	57
5.10 Service Settings (List of Default Values).....	58

CHAPTER 5 SERVICE PROGRAM

5.1 Outline

5.1.1 Functions

The following service program functions are available for field engineers to service or inspect XP Series instruments in the field.

- Service Sequence
- Service Settings
- Test Operation
- Service Data Vup
- Product Settings
- BBU Backup
- BBU Restore
- SNCS settings

Note that the service program can only be started when the instrument is in the service mode.

5.1.2 Entering Service Mode

To enter the service mode, use Hot Start, or enter service mode password “C9-0” when entering sample IDs on the main screen.

To start the service program, select [Service] icon (displayed only in the service mode) on the Menu screen.

5.1.3 Entering Service Mode using Hot Start

Turn ON the power switch. After “Sysmex” logo is displayed on the LCD screen, press and hold the Start switch until “Start up” is displayed.

5.1.4 Exiting Service Mode

To close the service program, press [Top] button in the service menu screen. The main screen will be displayed.

If [Top] button is pressed on any screen subsequent to the service menu screen, it will return to the service menu screen.

To enter the user mode from the service mode, enter user mode password “C0” when entering sample IDs on the main screen.

5.2 Service Menu

5.2.1 Service Menu Screen

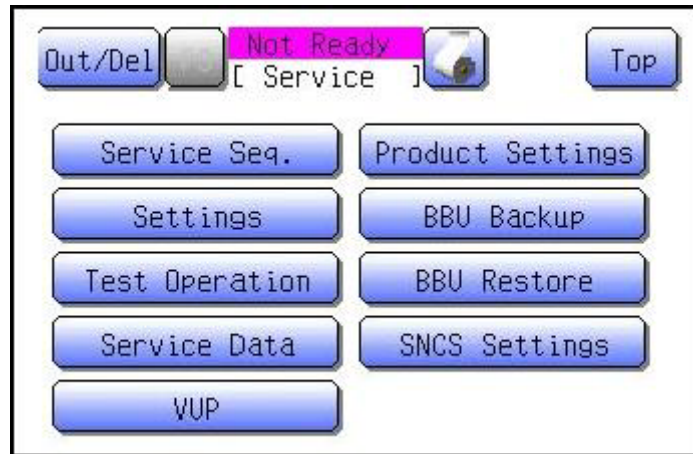

Service Menu Screen

Functions of the Buttons

Buttons	Functions
[Out/Del]	Displays the [Out/Del] menu.
[PS]	Captures the screen displayed (located to the right of Out/Del). (Displayed when SNCS setting is "SNCS Used".) (Print Screen)
(Printing paper feeder) 	Feeds printing paper.
[Top]	Returns to the main screen.
[Service Seq.]	Displays the service sequence menu screen.
[Settings]	Displays the service settings menu screen.
[Test Operation]	Displays the test menu screen.
[Service Data]	Prints out service data.
[VUP]	Displays program upgrade progress.
[Product Settings]	Displays the product program settings screen. (Not available in the field.)
[BBU Backup]	Displays the BBU RAM backup confirmation dialog box.
[BBU Restore]	Displays the BBU Restore confirmation dialog box.
[SNCS Settings]	Displays the SNCS Settings screen.

5.2.2 Menu Tree

User Menu	Out/Del	IP			
		GP			
		LP			
		HC			
		Delete			
		SNCS			
	*PS	(*Displayed when SNCS Settings are "SNCS Used")			
	 (Printing paper feeder)				
	Quality control analysis				
	Latest analysis results				
	Shutdown				
	Menu	Stored data			
		QC Chart			
		Chg.Reag			
		Maint.	Auto Rinse		
			Drain TD Chamber		
			Clean Transducer		
			Clean W. Chamber		
			Status Display		
			Calibration LCD		
Print Error Log					
SRV reset					
Calib.		Auto Calib.			
		Manual Calib.			
		Calibrator Calibration			
	Print Cal.His.				
Settings	System				
	Date/Time				
	Patient Limits				
	Quality Control				
	Instrument ID Setting				
	Host Output				
	Printer				
	Network				
	Password Setting				
	Print Settings				
PU Sleep					
Service Menu	Service	Service Seq.	Setting Seq.		
			Deprime Seq.		
			Gain Adjustment		
			Clog Adjustment		
			Control Mode		
			Calibrator Mode		
			Continuous Mode		
			Clog Removal		
			Initialization		
			Change		
	Settings		Print Settings		
		Test Operation	IP Output Test		
			GP Output Test		
			HC Output Test		
			LAN Output Test		
			SV/MT Test		
D Pump Test					
Compressor Test					
Service Data	VUP				
	Product Settings				
	BBU Backup				
	BBU Restore				
	SNCS Settings	Connect Settings			
		Network Settings			

5.3 Service Sequence

Service Sequence has the following functions.

- (1) Setting Seq.
- (2) Deprime Seq.
- (3) Gain Adjustment
- (4) Clog Adjustment
- (5) Control Mode
- (6) Calibrator Mode
- (7) Continuous Mode
- (8) Clog Removal

5.3.1 Service Sequence Menu

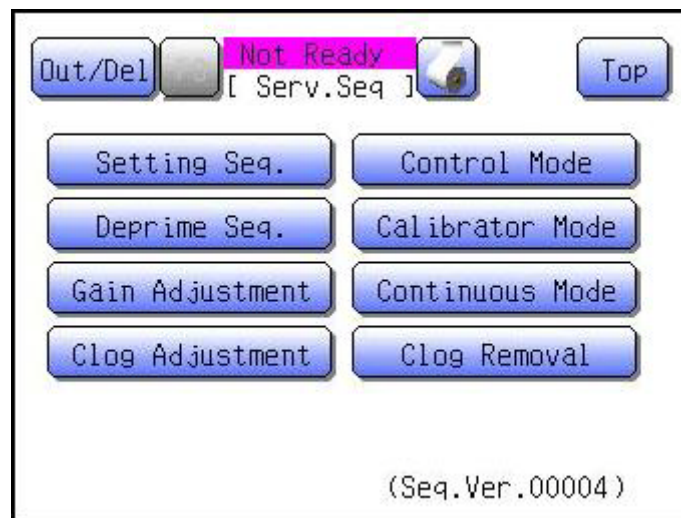

Service Sequence Menu Screen

Functions of the Buttons

Buttons	Functions
[Top]	Returns to the service menu.
[Setting Seq.]	Displays the Setting Sequence confirmation dialog box.
[Deprime Seq.]	Displays the Deprime Sequence confirmation dialog box.
[Gain Adjustment]	Displays the Gain Adjustment menu screen.
[Clog Adjustment]	Displays the Clog Adjustment screen.
[Control Mode]	Switches the control analysis mode ON and OFF. ^{*1, *2}
[Calibrator Mode]	Switches the calibrator analysis mode ON and OFF. ^{*1, *2}
[Continuous Mode]	Switches the continuous analysis mode ON and OFF. ^{*1}
[Clog Removal]	Displays the Clog Removal confirmation dialog box.

*1 When the setting is "ON", the button will be displayed as highlighted.

*2 Control Mode and Calibrator Mode cannot be turned ON at the same time. Therefore, if one is turned ON when the other is ON, turn one of them OFF and then turn the other ON.

Displayed information

Item	Detail
Seq.Ver.	Displays the sequence version obtained from CVAR of the sequence program. (0 ~ 65535)

5.3.2 Setting Sequence

This sequence is used to fill reagent efficiently at such times as when the instrument is being set up. To use this sequence, select “Setting Seq.” in the Service Seq. screen.

To execute the setting sequence, enter reagent barcodes in the following order:

CELLPACK -> STROMATOLYSER

(NOTE: It is not necessary to enter reagent barcodes on the XP-100 for China, as the reagent barcode screen will not be displayed on these instruments.)

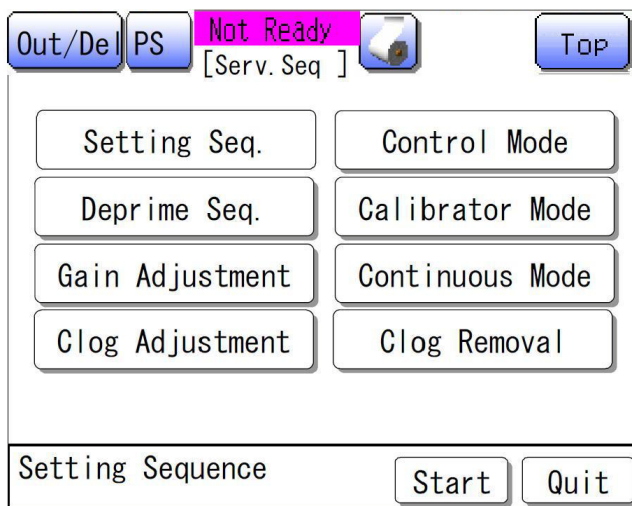

Setting Sequence Dialog Box

Functions of the Buttons

Buttons	Functions
[Start]	Displays the setting sequence (running) dialog box and starts a setting sequence. *1
[Quit]	Closes the dialog box.
Other buttons	Disabled * Excludes PS button

*1 When this sequence is to be executed or is in progress, “Setting Seq.” button is displayed as highlighted.

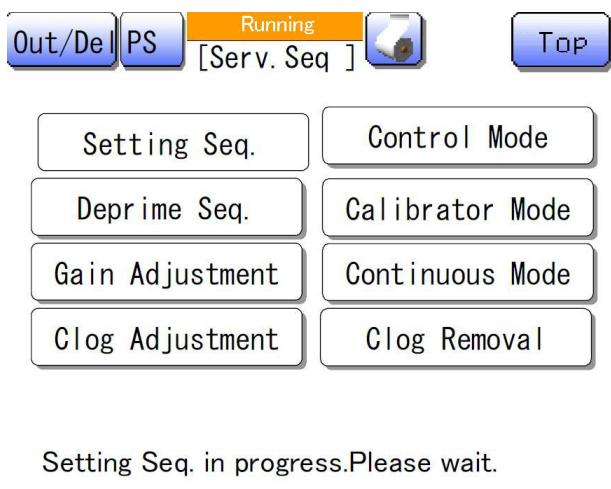

Setting Sequence (In Progress) Dialog Box

Functions of the Buttons

Buttons	Functions
All buttons	Disabled * Excludes PS button

5.3.3 Deprime Sequence

This sequence is used to drain fluid from the inside of the instrument at such times when packing the instrument. To use this sequence, select “Deprime Seq.” in the Service Seq. screen.

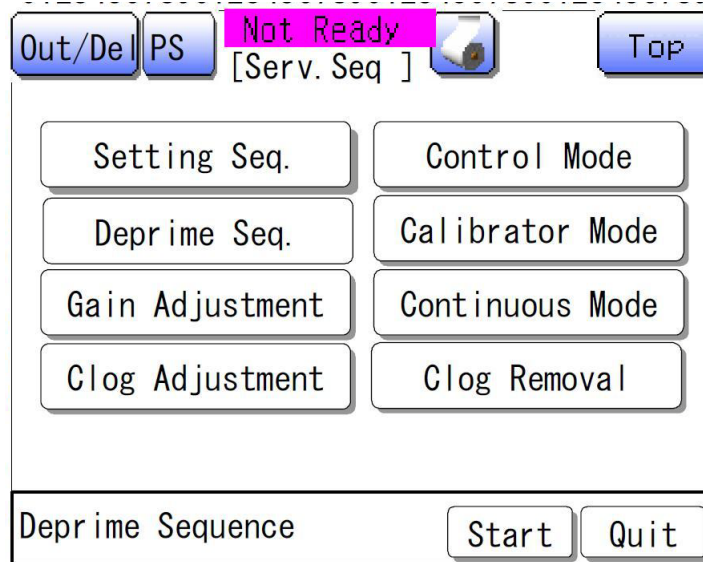

Deprime Sequence Dialog Box

Functions of the Buttons

Buttons	Functions
[Start]	Displays the Deprime Sequence dialog box and starts the deprime sequence.
[Quit]	Closes the dialog box.

- * When this sequence is to be executed or is in progress, “Deprime Seq.” button is displayed as highlighted.

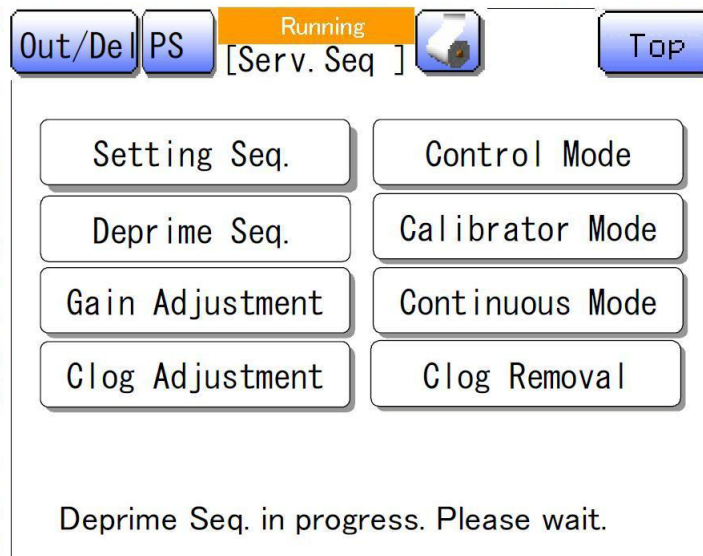

Deprime Sequence (In Progress) Dialog Box

Functions of the Buttons

Buttons	Functions
All buttons	Disabled * Excludes PS button

5.3.4 Gain Adjustment Sequence

This sequence is used to adjust WBC, RBC and PLT gain (sensitivity). Gain (sensitivity) is adjusted using standard substances, such as latex particles and CELLCHECK.

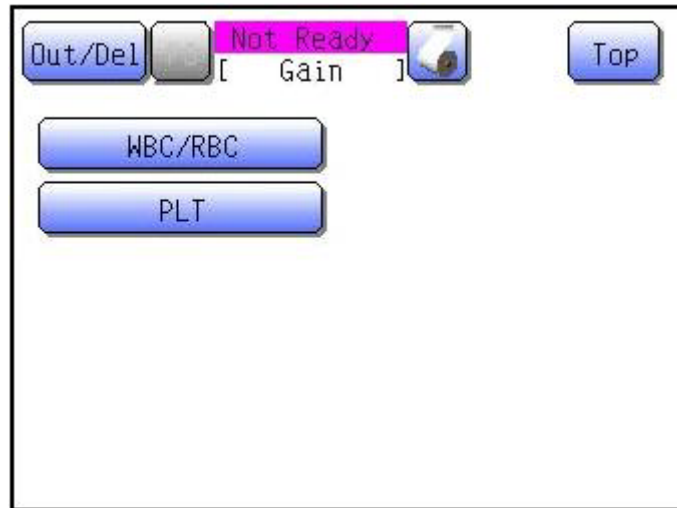

Gain Adjustment Menu Screen

Functions of the Buttons

Buttons	Functions
[Top]	Returns to the service menu screen.
[WBC/RBC]	Displays "Sequence Standby" dialog box to start the automatic gain adjustment preparation sequence. During the sequence, the [WBC/RBC] button will be displayed as highlighted. After the sequence is completed, the automatic gain adjustment settings screen (WBC/RBC) will be displayed.
[PLT]	Displays "Sequence Standby" dialog box to start the manual gain adjustment preparation sequence. During the sequence, the [PLT] button will be displayed as highlighted. After the sequence is completed, the manual gain adjustment settings screen (PLT) will be displayed.

5.3.4.1 Automatic Gain Adjustment Preparation Sequence (WBC/RBC)

The automatic gain adjustment preparation sequence is available for WBC and RBC gain adjustment. When this sequence is in progress, the selected button will be displayed as highlighted.

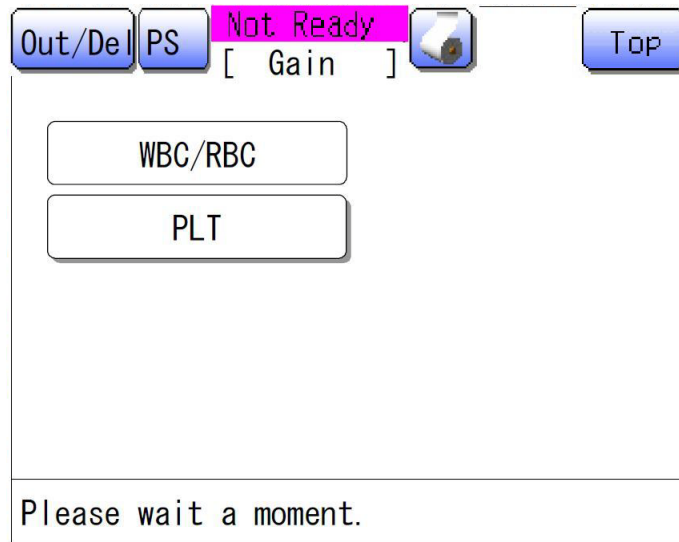

"Sequence Standby" Dialog Box (WBC/RBC)

5.3.4.2 Automatic Gain Adjustment Settings Screen (WBC/RBC)

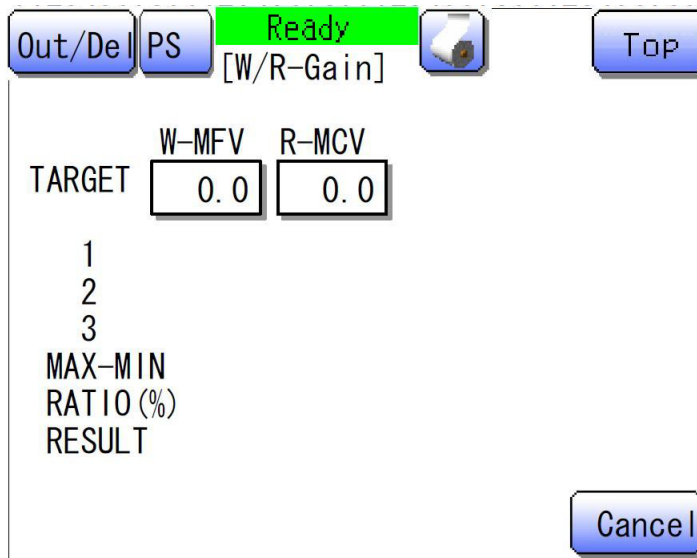

Automatic Gain Adjustment Settings Screen (WBC/RBC)

Functions of the Buttons

Buttons	Functions
[Target]	Displays a numeric keypad. There are target value fields for W-MFV and R-MCV. Up to 5-digit numbers can be entered in the target value fields. (Integral numbers: 3 digits, decimal point: 1 digit, and decimal numbers: 1 digit) The default value is 0.0.
[Cancel]	Stops WBC/RBC gain adjustment and returns to the Gain Adjustment screen. <ul style="list-style-type: none"> • Sets pre-adjustment values in WBC/RBC Gain Adjustment settings (potentiometer). • Starts the automatic gain adjustment cancellation sequence. After the sequence is completed, the service menu screen will be displayed. <p><How to start automatic gain adjustment> Enter target values, inject CELLCHECK for gain adjustment into Transducer and press the Start switch. The automatic gain adjustment (in progress) screen will be displayed and the automatic gain adjustment sequence will be started.</p> <ul style="list-style-type: none"> • Set WBC gain setting (potentiometer) at 125. • Set RBC gain setting (potentiometer) at 64.
Other buttons	Disabled

Displayed information

Items	Details
Name of screen	W/R-Gain
TARGET	Displays the current target values for the respective parameters. The unit to be displayed is fL for both WBC and RBC.

5.3.4.3 Canceling Automatic Gain Adjustment

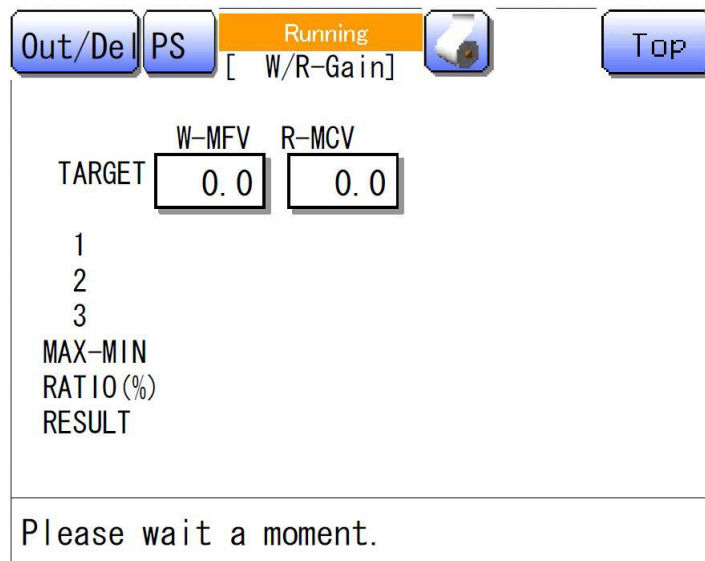

“Sequence Standby” Dialog Box

5.3.4.4 Automatic Gain Adjustment (In Progress) Screen

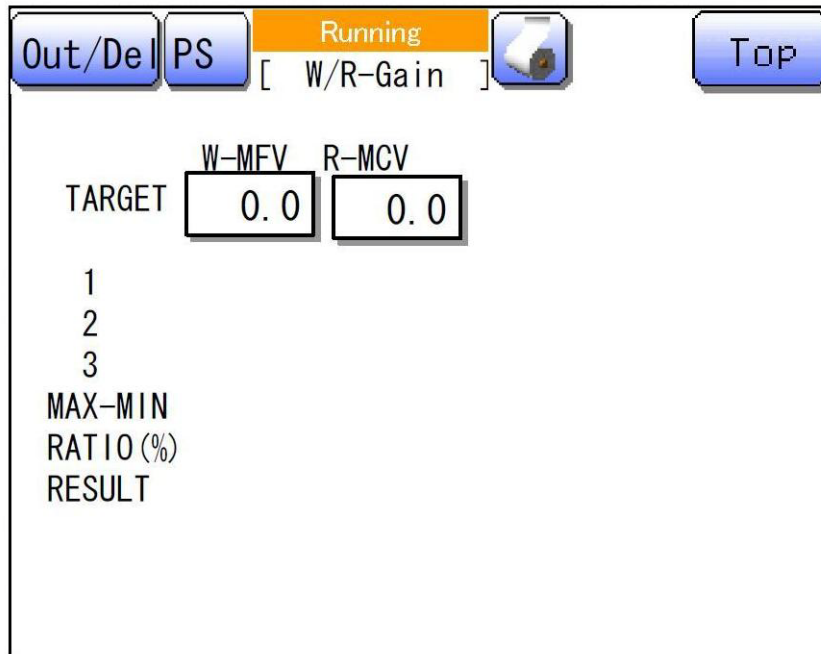

Automatic Gain Adjustment (In Progress) Screen (WBC/RBC)

Functions of the Buttons

Buttons	Functions
Other buttons	Disabled * Excludes PS button

5.3.4.5 How to Adjust Gain Automatically

In the automatic gain adjustment sequence, follow the procedures below to obtain new gains.

In 1st, 2nd and 3rd measurement and verification measurement, data will be obtained for approx. 15 seconds, respectively. While measurement is carried out 3 times, particles will flow continuously. The timing of each measurement depends on the custom command in the sequence program.

1. 1st measurement

Measure CELLCHECK-400 for Gain 1 (Setting value for WBC potentiometer: 125, setting value for RBC potentiometer: 64) to obtain W-MFV and R-MCV values.

2. 2nd measurement

Measure CELLCHECK-400 for Gain 2 (Setting value for WBC potentiometer: 125, setting value for RBC potentiometer: 64) to obtain W-MFV and R-MCV values.

3. 3rd measurement

Measure CELLCHECK-400 for Gain 3 (Setting value for WBC potentiometer: 125, setting value for RBC potentiometer: 64) to obtain W-MFV and R-MCV values.

4. Calculations

Calculate gains corresponding to target values (setting values for respective potentiometers) based on 1st, 2nd and 3rd measurement.

(1) Calculate X data value based on values obtained in 1st, 2nd and 3rd measurement.

$$X \text{ data} = (\text{Total of values obtained from 1st, 2nd and 3rd measurement} + 1.5) / 3$$

(2) Calculate setting values for potentiometers, using values calculated in (1) above.

$$\text{WBC: } ((1.010 \times \text{target value}) / X \text{ data} \times (1250 + 1242) - 1242) / 10$$

$$\text{RBC: } ((1.005 \times \text{target value}) / X \text{ data} \times (640 + 1242) - 1242) / 10$$

NOTE: These values are fixed if X data value is 0.

WBC : 125

RBC : 64

5. 1st verification measurement

Measure CELLCHECK-400 based on gain calculated in 4. above to obtain W-MFV and R-MCV values. If the difference from the target value is 2 ~ 10, obtain gain corresponding to the target value (setting value for potentiometer) once again and perform 2nd verification measurement.

$$\text{WBC: } (((1.010 \times (\text{target value} / \text{results of 1st verification measurement})) \times \text{target value}) / X \text{ data} \times (1250 + 1242) - 1242) / 10$$

$$\text{RBC: } (((1.005 \times (\text{target value} / \text{results of 1st verification measurement})) \times \text{target value}) / X \text{ data} \times (640 + 1242) - 1242) / 10$$

6. 2nd verification measurement

Measure CELLCHECK-400 based on gain calculated in 5. above to obtain W-MFV and R-MCV values.

5.3.4.6 Confirming Automatic Gain Adjustment Results (WBC/RBC)

	W-MFV	R-MCV
TARGET	172.0	134.8
1	173.5	134.8
2	175.5	131.8
3	174.5	132.3
MAX-MIN	2.0	1.0
RATIO (%)	98.6	101.9
RESULT	172.0	134.8

Confirm Result? OK Cancel

Confirming Automatic Gain Adjustment Results Dialog Box (WBC/RBC)

Functions of the Buttons

Buttons	Functions
[OK]	Updates settings and potentiometer values based on calculation results. Displays the service menu screen after displaying "Sequence Standby" dialog box. Prints adjustment results using the internal printer.
[Cancel]	Cancels calculation results and resets potentiometer values to the original values. Displays the service menu screen after displaying "Sequence Standby" dialog box.
Other buttons	Disabled * Excludes PS button

Displayed information

Items	Details
Name of screen	W/R-Gain
1~3	Calculates and displays W-MFV and R-MCV values obtained in each measurement (0.0 ~ 999.9).
MAX-MIN	Displays the difference between the maximum value and minimum value in 1st, 2nd and 3rd measurement.
Ratio(%)	Calculates and displays the ratio of 1st, 2nd and 3rd measurement results to target values.
Result	Calculates and displays W-MFV and R-MCV values obtained in verification measurement.

5.3.4.7 Manual Gain Adjustment Settings Screen (PLT)

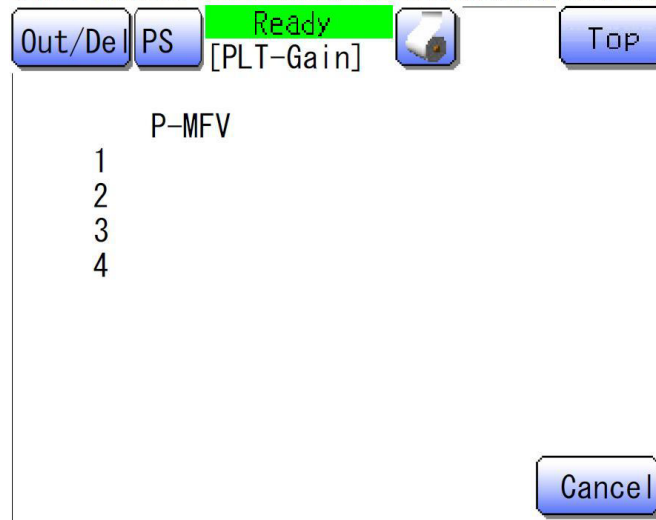

Manual Gain Adjustment Settings Screen (PLT)

Functions of the Buttons

Buttons	Functions
[Cancel]	Stops PLT gain adjustment. Displays the service menu screen after displaying the "Sequence Standby" dialog box.
Other buttons	Disabled * Excludes PS button

Displayed information

Item	Detail
Name of screen	PLT-Gain

Customers press the Start switch on the main unit to aspirate calibrator.

5.3.4.8 Cancelling Manual Gain Adjustment

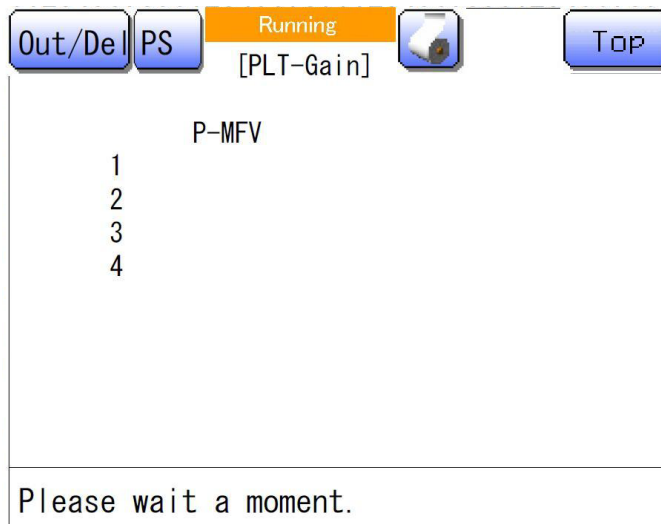

"Sequence Standby" Dialog Box

5.3.4.9 Manual Gain Adjustment (In Progress) Screen

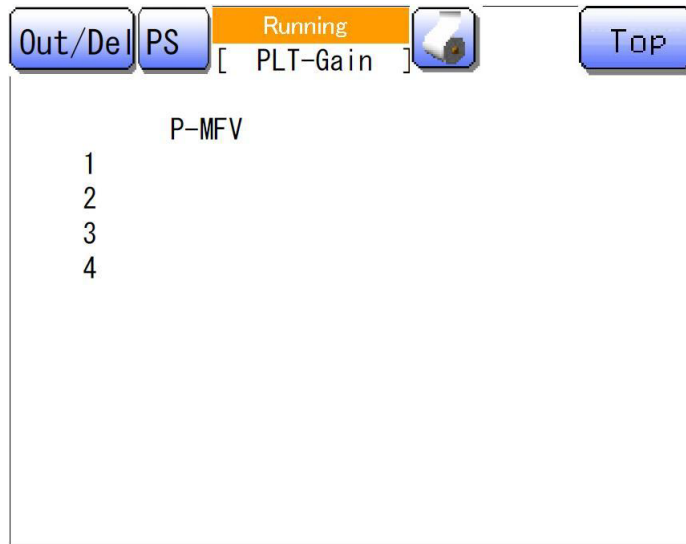

Manual Gain Adjustment (In Progress) Screen (PLT)

Functions of the Buttons

Buttons	Functions
All buttons	Disabled * Excludes PS button

5.3.4.10 Confirming Manual Gain Adjustment Results (PLT)

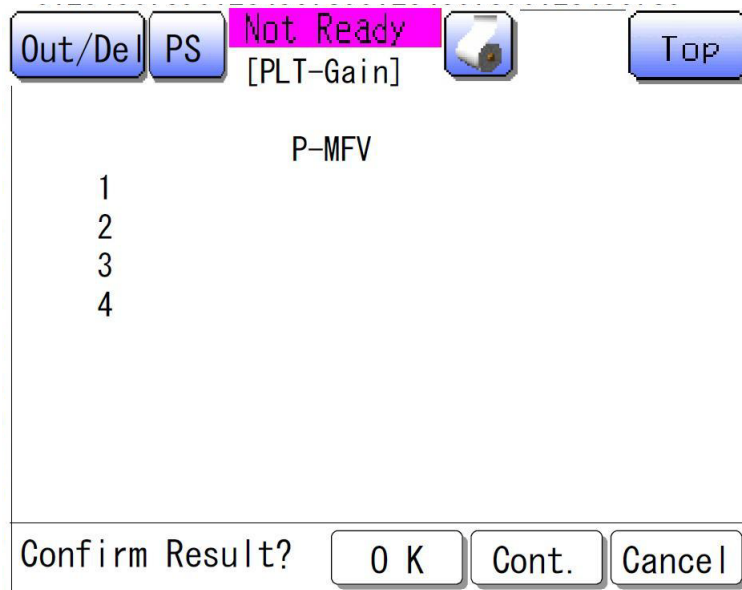

Confirming Manual Gain Adjustment Results Dialog Box (PLT)

Functions of the Buttons

Buttons	Functions
[OK]	Executes the PLT gain adjustment completion sequence. Displays the service menu screen after displaying the "Sequence Standby" dialog box.
[Cont.]	Executes the PLT gain adjustment continuance sequence. Continues PLT gain adjustment and opens the manual gain adjustment screen (PLT). Data for PLT gain being adjusted at this time will be deleted. Pressing the Start switch on the main unit will allow calibrator to be aspirated.
[Cancel]	Executes the PLT gain adjustment completion sequence. Displays the service menu screen after displaying the "Sequence Standby" dialog box.
Other buttons	Disabled * Excludes PS button

Displayed information

Items	Details
Name of screen	PLT-Gain
P-MFV	Calculates and displays P-MFV values obtained in respective measurements (0.0~999.9)

5.3.5 Clog Adjustment (Clog Voltage Adjustment Sequence)

Adjusts voltage to detect clogs in apertures.

With Transducer filled with diluent, voltage gain will be adjusted to detect clogs in apertures. Adjust gains manually using VR of PCBs. Procedure located in Adjustment Chapter.

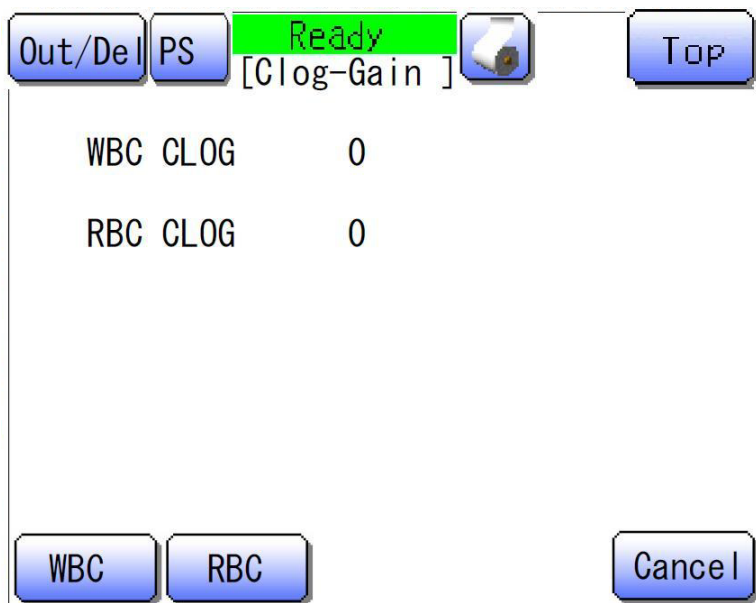

Clog Adjustment Screen

Functions of the Buttons

Buttons	Functions
[WBC]	Executes the clog voltage adjustment sequence for WBC.
[RBC]	Executes the clog voltage adjustment sequence for RBC.
[Cancel]	Stops the clog voltage adjustment sequence and displays the service menu screen.
Other buttons	Disabled * Excludes PS button

Displayed information

Items	Details
Name of screen	Clog-Gain
WBC CLOG	Displays the results of WBC clog level measurement in real time.
RBC CLOG	Displays the results of RBC clog level measurement in real time.

5.3.5.1 Clog Adjustment (In Progress) Screen

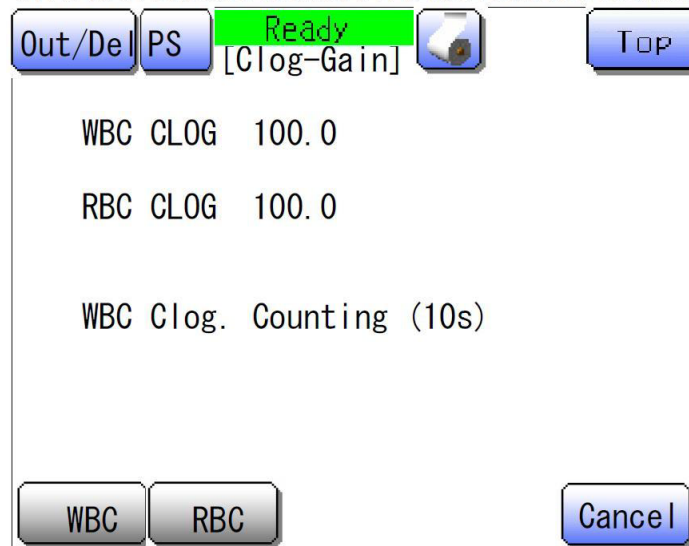

Clog Adjustment (In Progress) Screen

Functions of the Buttons

Buttons	Functions
[Cancel]	Stops the clog voltage adjustment sequence and displays the service menu screen.
All buttons	Disabled * Excludes PS button

Displayed information

Items	Details
WBC CLOG	Displays the results of WBC clog level measurement in real time.
RBC CLOG	Displays the results of RBC clog level measurement in real time.
WBC Clog Counting, RBC Clog Counting	Displays time progress in the sequence (0-30 seconds).

5.3.6 Control Mode

Select [Control Mode] in the Service Seq. menu to enter the control blood analysis mode. In the control blood analysis mode, only data for control blood will be analyzed in normal analysis. "QC" will be displayed in the area for selecting analysis mode in the main screen. If the control analysis mode is selected while the instrument is in the calibrator analysis mode, the calibrator analysis mode will be cancelled and the instrument will enter the control analysis mode.

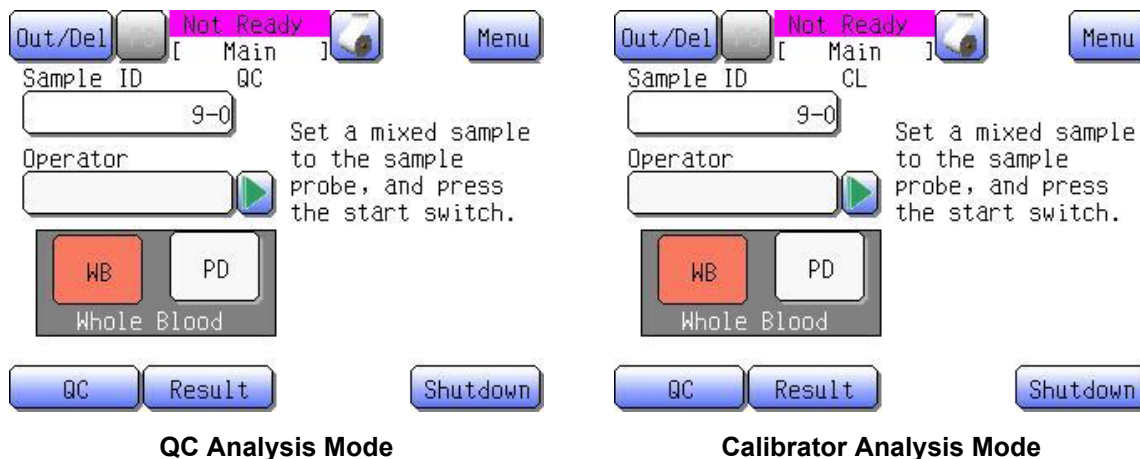

5.3.7 Calibrator Mode

Select [Calibrator Mode] in the Service Seq. menu to enter the calibrator analysis mode. In the calibrator analysis mode, only data for calibrator will be analyzed in normal analysis. "CL" will be displayed in the area for selecting analysis mode in the main screen. If the calibrator analysis mode is selected while the instrument is in the control analysis mode, the control analysis mode will be cancelled and the instrument will enter the calibrator analysis mode.

5.3.8 Continuous Mode

Select [Continuous Mode] in the Service Seq. menu to enter the continuous analysis mode. In normal analysis, analysis will be performed continuously. (After an analysis is completed, the subsequent analysis will start automatically. From there on, analysis will be performed successively.)

If the "Cancel" button is pressed during the last rinsing in an analysis (Analysis results screen), a "beep" will sound and continuous analyses will be terminated after the analysis currently in progress is completed. (Note that the continuous mode will not be canceled.)

If an error occurs during the continuous mode, continuous analyses will be terminated. (Note that the continuous mode will not be canceled.)

5.3.9 Clog removal

5.3.9.1 "Run Clog Removal" Screen

Starts the clog removal sequence.



"Run Clog Removal" Screen

Functions of the Buttons

Buttons	Functions
[Execute]	Executes the clog removal sequence. The "clog removal (in progress) screen will be displayed.
[Cancel]	Cancels clog removal and displays the service menu screen.
Other buttons	Disabled * Excludes PS button

5.3.9.2 Clog Removal (In Progress) Screen

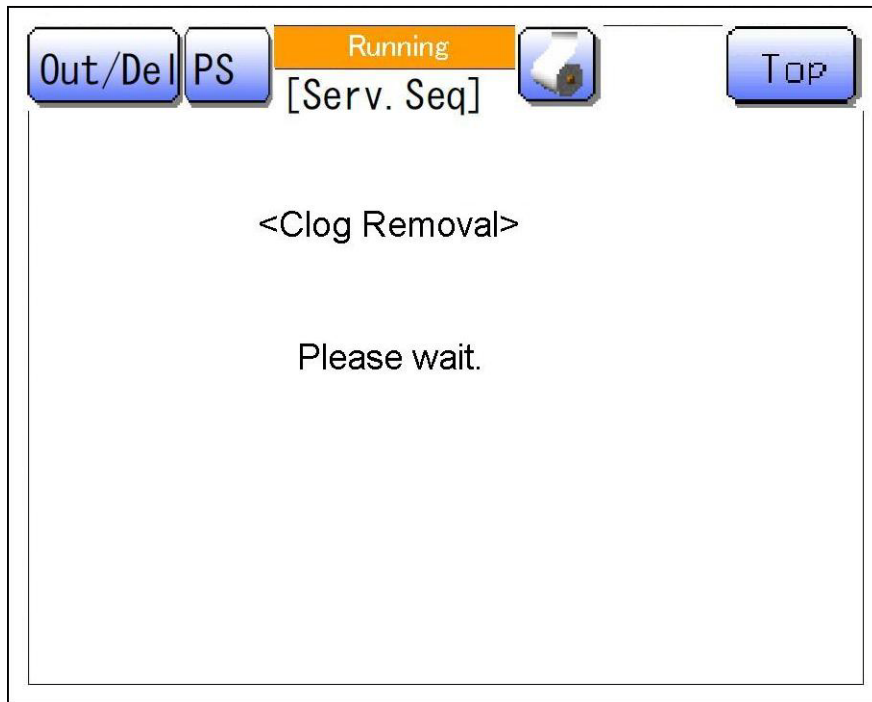

Clog Removal (In Progress) Screen

Functions of the Buttons

Buttons	Functions
All buttons	Disabled * Excludes PS button

5.4 Settings

This is used to initialize, change and print out settings for field engineers.

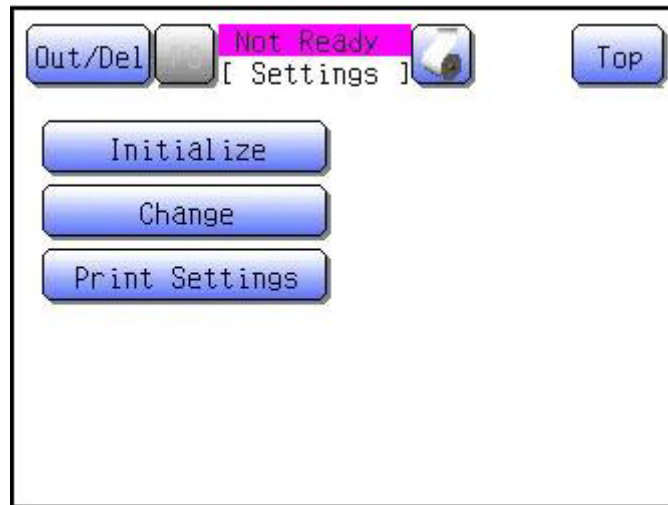

Settings Screen

Functions of the Buttons

Buttons	Functions
[Initialize]	Displays "Initialize" menu screen.
[Change]	Displays "Change" menu screen.
[Print Settings]	Prints out service settings.

5.4.1 Initialize

This menu is used to initialize settings. When a button in this “Initialize” menu is pressed, the initial values for the button pressed will be reset to factory default values for the applicable destination. (Refer to 5.10 Service Settings (List of Default Values)).

Items to be initialized are as follows: cycle count, calibration values, stored data, QC data, Hardware Limit and other settings

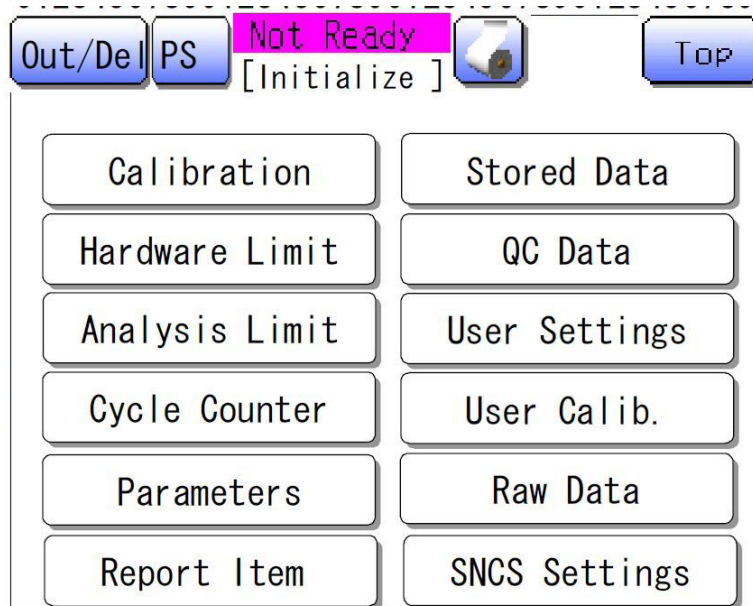

“Initialize” Menu Screen

Functions of the Buttons

Buttons	Functions
[Top]	Returns to the service menu screen.
[Calibration]	Displays the “Confirm Initialization” screen.
[Hardware Limit]	Displays the “Confirm Initialization” screen.
[Analysis Limit]	Displays the “Confirm Initialization” screen.
[Parameters]	Displays the “Confirm Initialization” screen.
[Cycle Counter]	Displays the “Confirm Initialization” screen.
[Stored Data]	Displays the “Confirm Initialization” screen.
[QC Data]	Displays the “Confirm Initialization” screen.
[User Settings]	Displays the “Confirm Initialization” screen.
[User Calib.]	Displays the “Confirm Initialization” screen.
[Raw Data]	Displays the “Confirm Initialization” screen.
[Report Item]	Displays the “Confirm Initialization” screen.
[SNCS Settings]	Displays the “Confirm Initialization” screen.

* The “Confirm Initialization” screen will be displayed, with the selected button being highlighted.

5.4.1.1 “Confirm Initialization” Dialog Box

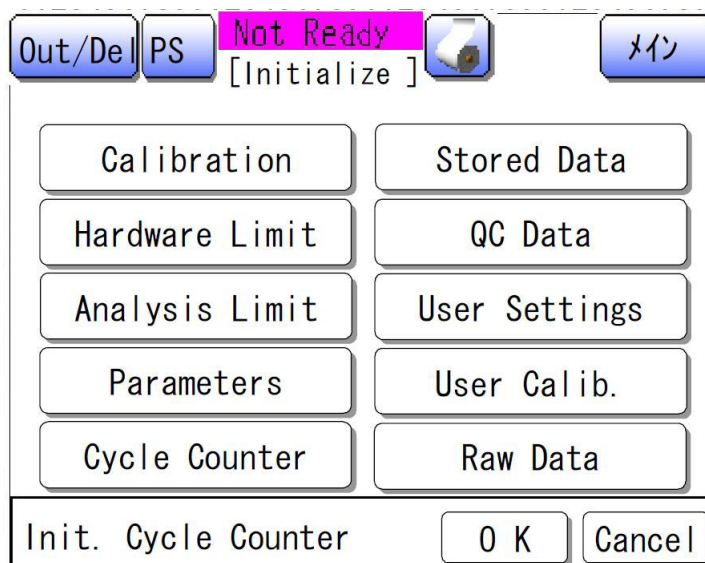

“Confirm Initialization” Dialog Box

Functions of the Buttons

Buttons	Functions
[OK]	Initializes the specified data and then closes the dialog box.
[Cancel]	Closes the dialog box.
Other buttons	Disabled * Excludes PS button

5.4.1.2 Items to be initialized

Menu and Message in the Dialog Box	Items to be initialized
Calibration	Calibration values (Service)
Hardware Limit	Hardware Limit (Service)
Analysis Limit	Analysis Limit (Service)
Parameters	Parameter settings (Service)
Cycle Counter	Cycle counts, periodic maintenance data, error log, calibration history, logging data
Stored Data	Stored data files While initialization is in progress, message “Please wait. (approx. 10 minutes)” will be displayed.
QC Data	QC files
User Settings	Customer settings (excludes time, e.g., year, month, day, hour, minute)
User Calib.	Customer calibration values (whole blood / diluent) (HGB, HCT, WBC, RBC, PLT)
Raw Data	Raw data stored in the DOS domain. * Initialization will delete the whole folder that stores raw data.
Report Item	Settings related to Report Item (Refer to 5.4.2.7 Report Item.)
SNCS Settings	Settings related SNCS (Refer to 5.9 SNCS Settings.)

5.4.2 Change

This menu is used to change calibration values, hardware limit values and other settings.

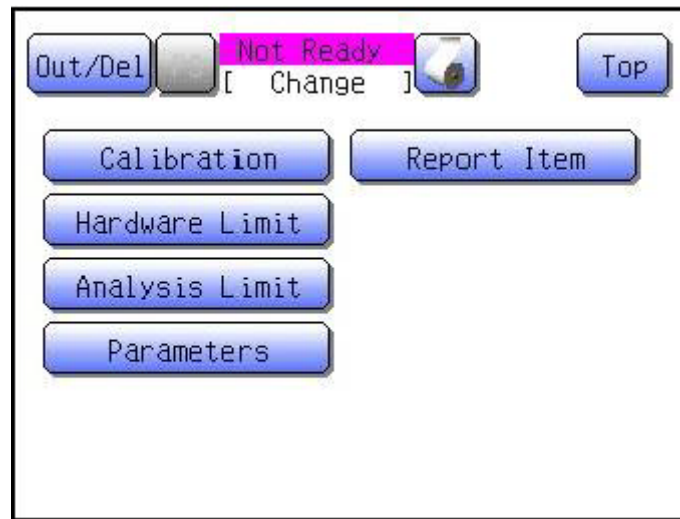

“Change Service Settings” Menu Screen

Functions of the Buttons

Buttons	Functions
[Top]	Returns to the service menu screen.
[Calibration]	Displays the 1st calibration settings screen.
[Hardware Limit]	Displays the 1st Hardware Limit screen.
[Analysis Limit]	Displays the 1st Analysis Limit screen.
[Parameters]	Displays the parameter setting screen.
[Report Item]	Displays the 1st Report Item screen.

5.4.2.1 Calibration

This menu is used to set calibration values.

The input range for each parameter is 0.0 ~ 999.9.

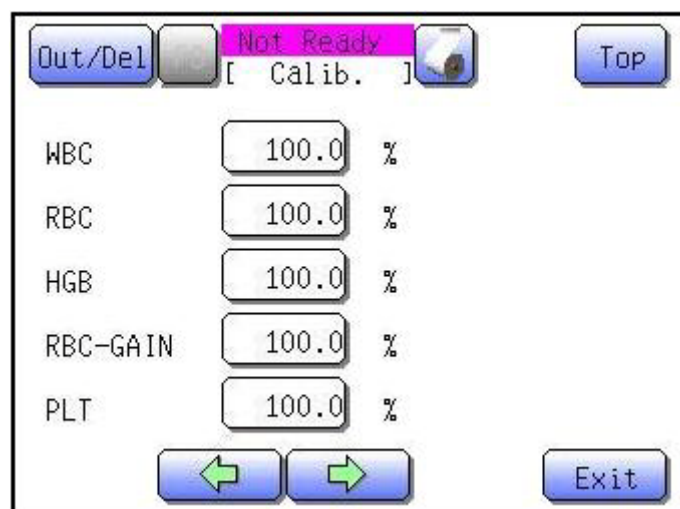

Calibration Value Setting Screen

Functions of the Buttons

Buttons	Functions
[Top]	Displays the setting cancel confirmation dialog box.
[←]	This button is used to switch screens in descending order. (i.e. 1st screen -> 7th screen -> 6th screen... -> 1st screen)
[→]	This button is used to switch screens in ascending order. (i.e. 1st screen -> 2nd screen ->... 7th screen -> 1st screen)
Parameter buttons	A numeric keypad is displayed to enter values.
[Exit]	Displays the setting storing confirmation dialog box.

Displayed information

Items	Details
Values for the respective parameters	<p>Current settings or values being entered</p> <p>1st screen: WBC, RBC^{*1}, HGB, RBC-GAIN, PLT (Input range: 0.0 ~ 999.9, Unit: %)</p> <p>2nd screen: W-SCR, W-MCR, RDW-SD, RDW-CV (Input range: 0.0 ~ 999.9, Unit: %)</p> <p>3rd screen: PDW, MPV, P-LCR, PCT (Input range: 0.0 ~ 999.9, Unit: %)</p> <p>4th screen: WBC(P), RBC(P)^{*1}, HGB(P), RBC-GAIN(P), PLT(P) (Input range: 0.0 ~ 999.9, Unit: %)</p> <p>5th screen: W-SCR(P)^{*2}, W-MCR(P)^{*2}, RDW-SD(P), RDW-CV(P) (Input range: 0.0 ~ 999.9, Unit: %)</p> <p>6th screen: PDW(P), MPV(P), P-LCR(P), PCT(P) (Input range: 0.0 ~ 999.9, Unit: %)</p> <p>7th screen: WBC-SENS, RBC-SENS^{*3} (Input range: 0 ~ 255, Unit is not displayed)</p>

- *1 Settings will affect analyzed HCT values.
- *2 Settings will not affect these values.
- *3 Use the following formulas to calculate values to be set in potentiometer. (Use user calibration value HCT and RBC GAIN for the whole blood mode. Use HCT, RBC GAIN and RBC GAIN(P) for the diluted mode.)

Whole Blood Mode:(PRS) = (RBC-SENS) × (HCT) × (RBC GAIN)

Diluted Mode: : (PRS) = (RBC-SENS) × (HCT) × (RBC GAIN) × (RBC GAIN(P))

PRS : Settings for potentiometer (RBC-SENS)
RBC-SENS : Settings for service gain (RBC-SENS)
HCT : Settings for customer calibration (HCT)
RBC GAIN : Settings for service calibration (RBC GAIN)
RBC GAIN(P) : Settings for service calibration (RBC GAIN(P))

Item Name	Details
WBC-SENS	WBCch gain adjustment value (potentiometer: 5ch)
RBC-SENS	RBCch gain adjustment value (potentiometer: 3ch)

5.4.2.2 Setting Storing Confirmation Dialog Box

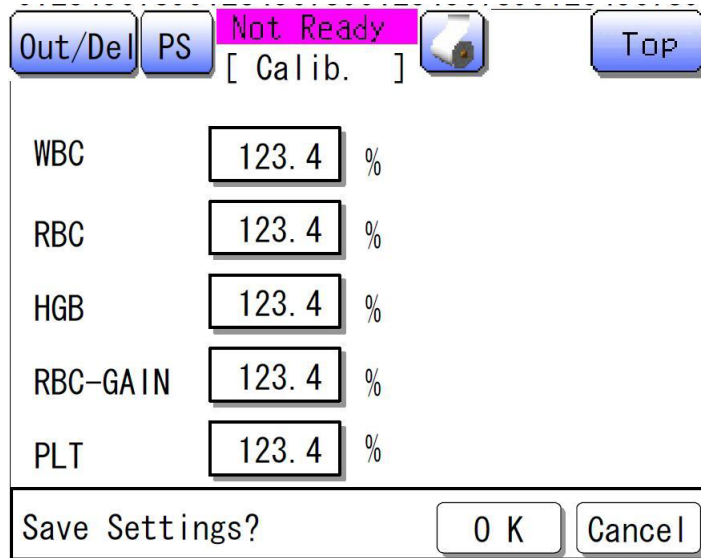

Setting Storing Confirmation Dialog Box

Functions of the Buttons

Buttons	Functions
[OK]	Saves settings and then displays the “Change Service Settings” menu.
[Cancel]	Closes the dialog box to continue the settings.

5.4.2.3 Setting Cancel Confirmation Dialog Box

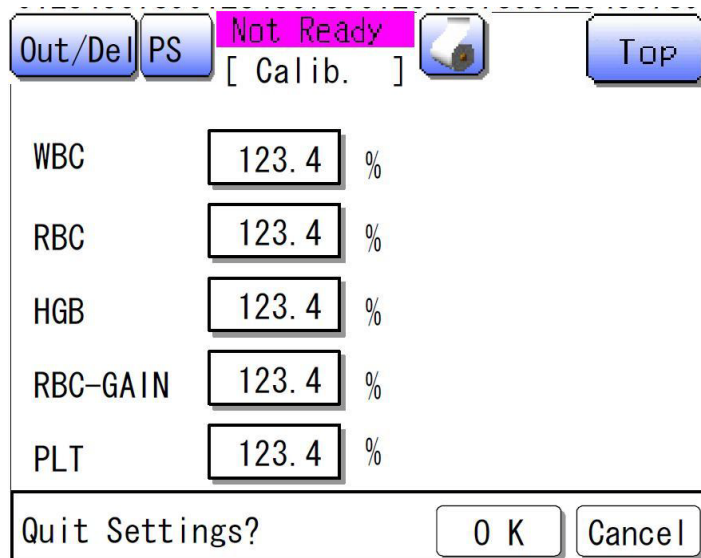

Setting Cancel Confirmation Dialog Box

Functions of the Buttons

Buttons	Functions
[OK]	Cancels the settings and displays the service menu screen.
[Cancel]	Closes the dialog box to continue the settings.

5.4.2.4 Hardware Limit

This function is to change hardware limit.

Refer to [5.4.2.1 Calibration](#) for how to change hardware limit.

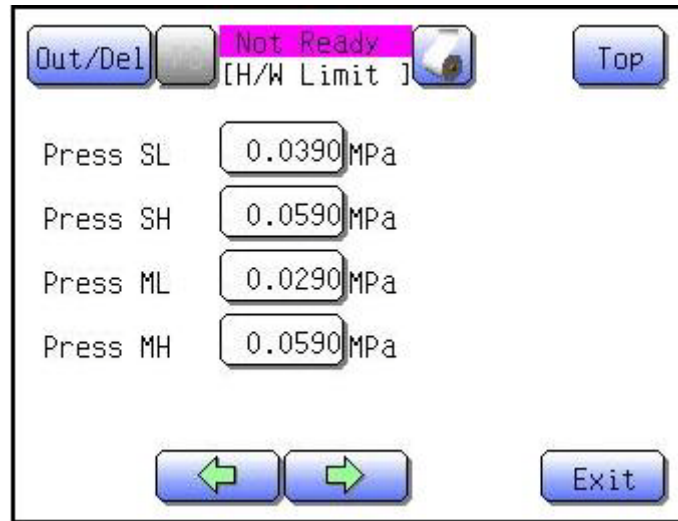

Hardware Limit Setting Screen

Functions of the Buttons

Buttons	Functions
[Top]	Displays the setting cancel confirmation dialog box (Same as Calibration settings).
[←]	This button is used to switch screens in descending order. (i.e. 1st screen -> 6th screen ... -> 1st screen)
[→]	This button is used to switch screens in ascending order. (i.e. 1st screen -> 2nd screen -> ...6th screen -> 1st screen)
Parameter buttons	A numeric keypad is displayed to enter values.
[Exit]	Displays the setting storing confirmation dialog box (Same as Calibration settings).

Displayed information

Items	Details
Values for the respective parameters	Current settings or values being entered 1st screen: Press SL, Press SH, Press ML, Press MH 2nd screen: Press RL, Press RH 3rd screen: VAC SL, VAC SH, VAC ML, VAC MH 4th screen: WC PERIOD, WC COUNT, TD PERIOD, TD COUNT 5th screen: SRV PERIOD, SRV COUNT, RES L, RES H 6th screen: TEMP H, TEMP L, WH LIMIT, SLEEP TMR

Input items

Item Name	Details
TEMP H	Temperature monitor upper limit, input range: (0.0 ~ 999.9)
TEMP L	Temperature monitor lower limit, input range: (0.0 ~ 999.9)
WC PERIOD	Frequency of periodic maintenance (Cleaning Waste Chamber) (days) Input range: (0 ~ 9999) * Periodic maintenance will be carried out even if the value is set at "0".
WC COUNT	Frequency of periodic maintenance (Cleaning Waste Chamber) (cycle counts) Input range: (0 ~ 9999) * Periodic maintenance will be carried out even if the value is set at "0".
TD PERIOD	Frequency of periodic maintenance (Cleaning Transducer) (days) Input range: (0 ~ 9999) * Periodic maintenance will be carried out even if the value is set at "0".
TD COUNT	(0~9999) Frequency of periodic maintenance (Cleaning Transducer) (cycle counts) Input range: (0 ~ 9999) * Periodic maintenance will be carried out even if the value is set at "0".
SRV PERIOD	Frequency of periodic maintenance (Cleaning SRV) (days) Input range: (0 ~ 9999) * Periodic maintenance will be carried out even if the value is set at "0".
SRV COUNT	Frequency of periodic maintenance (Cleaning SRV) (cycle counts) Input range: (0 ~ 9999) * Periodic maintenance will be carried out even if the value is set at "0".
SLEEP TMR	Sleep timer time Input range: (0 ~ 9999) * The instrument will not enter the Sleep mode when this value is set at "0". * The time will not be reset at the time of setting. (The time will be reset when a sequence is completed.) (Default: 15 mins)
Press SL	Pressure monitor lower limit (in Ready mode) (Default: 0.039MPa)
Press SH	Pressure monitor upper limit (in Ready mode) (Default: 0.059MPa)
Press ML	Pressure monitor lower limit (during analysis) (Default: 0.03 MPa)
Press MH	Pressure monitor upper limit (during analysis) (Default: 0.059 MPa)
Press RL	Not used (Default: 0.02 MPa)
Press RH	Not used (Default: 0.059 MPa)
VAC SL	Vacuum monitor lower limit (in Ready mode) (Default: 0.0307 MPa)
VAC SH	Vacuum monitor upper limit (in Ready mode) (Default: 0.036 MPa)
VAC ML	Vacuum monitor lower limit (during analysis) (Default: 0.0134 MPa)
VAC MH	Vacuum monitor upper limit (during analysis) (Default: 0.036 MPa)
RES L	Electric conductivity monitor lower limit (Default: 80)
RES H	Electric conductivity monitor upper limit (Default: 125)
WH LIMIT	Lysing reagent monitoring limit. The number of cycles the instrument reports an error after the WH lyse bottle float switch changes to ON (lowermost position). (Default: 95: Times)

* The format of the unit displayed differs from the default unit setting.

5.4.2.5 Analysis Limit

This menu is used to change analysis limit.

Refer to [5.4.2.1 Calibration](#) for how to change analysis limit.

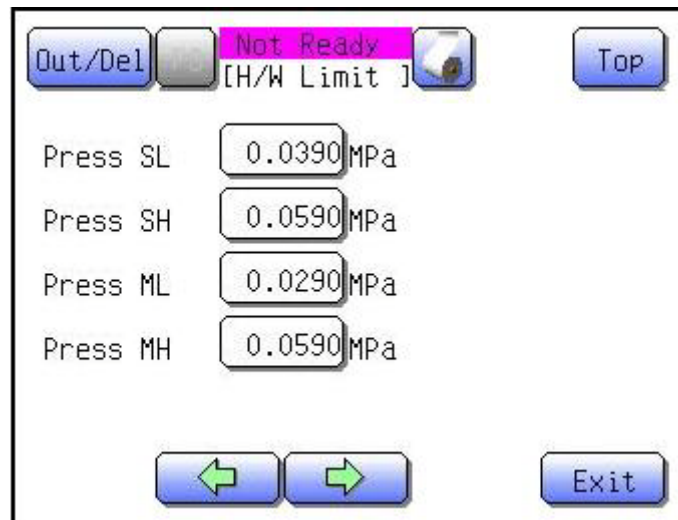

Analysis Limit Setting Screen

Functions of the Buttons

Buttons	Functions
[Top]	Displays the setting cancel confirmation dialog box (Same as Calibration settings).
[←]	This button is used to switch screens in descending order. (i.e. 1st screen -> 5th screen ... -> 1st screen)
[→]	This button is used to switch screens in ascending order. (i.e. 1st screen -> 2nd screen -> ...5th screen -> 1st screen)
Parameter buttons	A numeric keypad is displayed to enter values.
[Exit]	Displays the setting storing confirmation dialog box (Same as Calibration settings).

Displayed information

Items	Details
Values for the respective parameters	Current settings or values being entered 1st screen: BLANK W, BLANK R, BLANK P, BLANK H 2nd screen: CLOG W, CLOG R 3rd screen: AG LIMIT, WL MASK, PL LMT 4th screen: SMP LMT W, SMP LMT R, SMP LMT P 5th screen: SMP OFF W, SMP OFF R, SMP OFF P

Input items

Item Name	Details
BLANK W	WBC background limit, input range (0 ~ 9999) , unit: x 10 ² /uL
BLANK R	RBC background limit, input range (0 ~ 9999) , unit: x 10 ⁴ /uL
BLANK P	PLT background limit, input range (0 ~ 9999) , unit: x 10 ⁹ /uL
BLANK H	HGB background limit, input range (0 ~ 9999) , unit: x 10 ⁻¹ g/dL
CLOG W	WBC clog monitoring (rbc_clog_h), input range (0 ~ 9999), Unit is not displayed
CLOG R	RBC clog monitoring (rbc_clog_h), input range (0 ~ 9999), Unit is not displayed
AG LIMIT	AG flag rating, input range (0 ~ 9999), Unit is not displayed
WL MASK	WL masking rating (Masks WBC-related data as LD for WBC is high.), input range (0 ~ 9999), Unit is not displayed
PL LMT	PL flag rating, input range (0 ~ 9999), unit:%
SMP LMT W	Threshold for WBC sampling error rating formula, input range (0 ~ 999.9), unit:%
SMP LMT R	Threshold for RBC sampling error rating formula, input range (0 ~ 999.9), unit:%
SMP LMT P	Threshold for PLT sampling error rating formula, input range (0 ~ 999.9), unit:%
SMP OFF W	Offset value for WBC sampling error rating formula, input range (0 ~ 9999), Unit is not displayed
SMP OFF R	Offset value for RBC sampling error rating formula, input range (0 ~ 9999), Unit is not displayed
SMP OFF P	Offset value for PLT sampling error rating formula, input range (0 ~ 9999), Unit is not displayed

* The format of the unit displayed differs from the default unit setting.

5.4.2.6 Parameters

This menu is used to make settings, such as to use/not use calibrator, PDW/P-LCR output, PS Code and saving raw data.

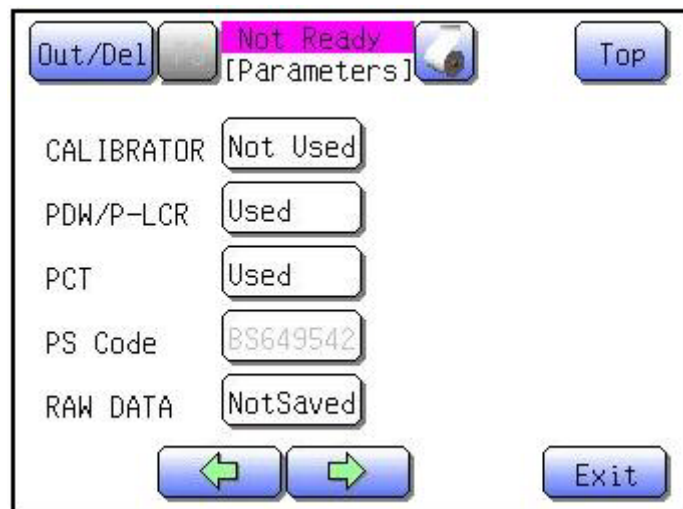

Parameter Setting Screen

Functions of the Buttons

Buttons	Functions
[Top]	Displays the setting cancel confirmation dialog box (Same as Calibration settings).
[←]	This button is used to switch screens in descending order. (i.e. 1st screen -> 3rd screen -> 2nd screen -> 1st screen)
[→]	This button is used to switch screens in ascending order. (i.e. 1st screen -> 2nd screen -> 3rd screen -> 1st screen)
Parameter buttons	For PS CODE, ISBTstart and ISBTend buttons, a numeric keypad will be displayed. For other parameters, options will be displayed.
[Exit]	Displays the setting storing confirmation dialog box (Same as Calibration settings).

Displayed information

Items	Details
Values for the respective parameters	Current settings or values being entered (0 ~ 2000) 1st screen: CALIBRATOR, PDW/P-LCR, PS Code, RAW DATA 2nd screen: ISBTstart, ISBTend, OPERATOR 3rd screen: ASTM QC Out, RESEARCH W, CELLPACK

Input items

Items	Options
PS CODE	Up to 8 numerical numbers. The default setting is "BL783052". * Differs depending on the destination.
ISBTstart ^{*1}	ISBT128 sample ID start position (Input range: 0-32 [digits]) The default value is "1". However, an alarm will sound and entry will not be accepted if (1) ISBTstart setting is larger than ISBTend setting; and (2) the difference from ISBTend is larger than 15 digits.
ISBTend ^{*1}	ISBT128 sample ID end position (Input range: 0-32 [digits]) The default value is "13". However, an alarm will sound and entry will not be accepted if (1) ISBTend setting is smaller than ISBTstart setting; and (2) the difference from ISBTstart is larger than 15 digits.

*1 Example of using ISBT128, "ISBTstart", "ISBTend"

ISBTstart setting : 1

ISBTend setting : If the value is 13, the first digit (from the left) of the barcode entered (1st position: 0) through the 13th digit (from the left) will be displayed as sample ID.

Barcode (ISBT128) sample ID display

"&W123496123456441" -> "W123496123456"
01234567890123456

Options

Items	Options
CALIBRATOR	Used / Not Used ^{*1}
PDW/P-LCR	Used ^{*1} / Not Used Setting of whether or not to display PDW/P-LCR
PCT	Used ^{*1} / Not Used Setting of whether or not to display PCT
RAW DATA	Saved / NotSaved ^{*1}
OPERATOR	Used ^{*1} / Not Used Setting of whether or not to use operator ID
ASTM QC Out	QC File ^{*1} / Ctrl Lot / File+Lot ASTM output settings for QC file information
RESEARCH W	Used ^{*1} / Not Used Setting of whether or not to use WBC research items
CELLPACK	CELLPACK ^{*1} / B1 Reagent package settings

*1 Default setting

(1) Unit settings (Type 1 ~ Type 6) A

- Type 1: For Japan
- Type 2: For general export
- Type 3: For Canada SI
- Type 4: For the Netherlands SI
- Type 5: For Standard SI
- Type 6: For Hong Kong SI

(2) Print type settings (Type ~ Type 3) A

- Type 1: All analysis parameters + Particle size distribution + Research parameters
- Type 2: All analysis parameters + Research parameters
- Type 3: 8 CBC parameters + ResearchW

	ResearchW	ResearchS	ResearchM	ResearchL
Type1	○	○	○	○
Type2	○	○	○	○
Type3	○			

ResearchW represents WBC (Total of ResearchS, ResearchM and ResearchL).

ResearchS represents W-SCR and W-SCC.

ResearchM represents W-MCR and W-MCC.

ResearchL represents W-LCR and W-LCC.

NOTE: (1) Unit settings and (2) Print type settings are user settings parameters.

A 201297

5.4.2.7 Report Item

This menu is used to set report items.

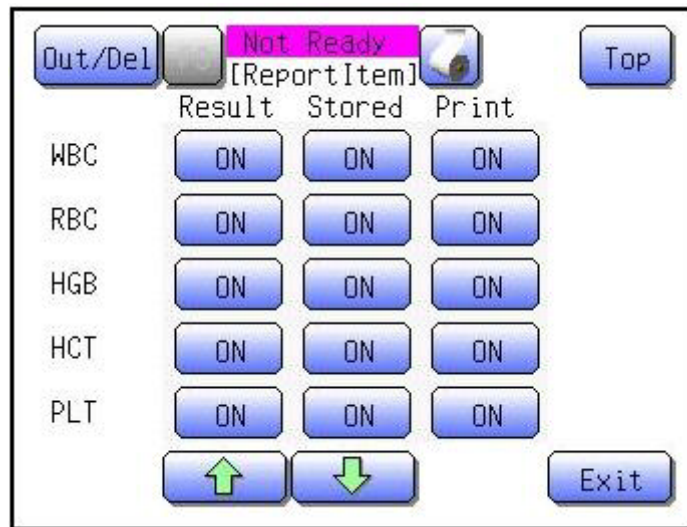

Functions of the Buttons

Buttons	Functions
[Top]	Displays the setting cancel confirmation dialog box.
[↑]	This button is used to switch screens in descending order. (i.e. 1st screen ->5th screen ->4th screen -> 1st screen)
[↓]	This button is used to switch screens in ascending order. (i.e. 1st screen -> 2nd screen ->5th screen -> 1st screen)
Setting buttons [ON] / [OFF]	These buttons are used to switch between [ON] and [OFF].
[Exit]	Displays the setting storing confirmation dialog box.

Displayed information

Items	Details
Name of screen	"ReportItem"
Names of report items	1st screen: WBC, RBC, HGB, HCT, PLT 2nd screen: MCV, MCH, MCHC 3rd screen: W-SCR, W-MCR, W-LCR 4th screen: W-SCC, W-MCC, W-LCC, RDW-SD, RDW-CV 5th screen: PDW, MPV, P-LCR, PCT

5.4.3 Print Settings

This menu is used to print out all settings.

5.5 Test Operation

This menu is used to perform single tests for diaphragm pump operation, solenoid valve/ motor operation and tests for HC output and printer output, enabling field engineers to check operations and carry out repairs.

- (1) IP Output Test
- (2) GP Output Test
- (3) HC Output Test
- (4) LAN Output Test
- (5) SV / MT Test
- (6) D Pump Test
- (7) Compressor Test

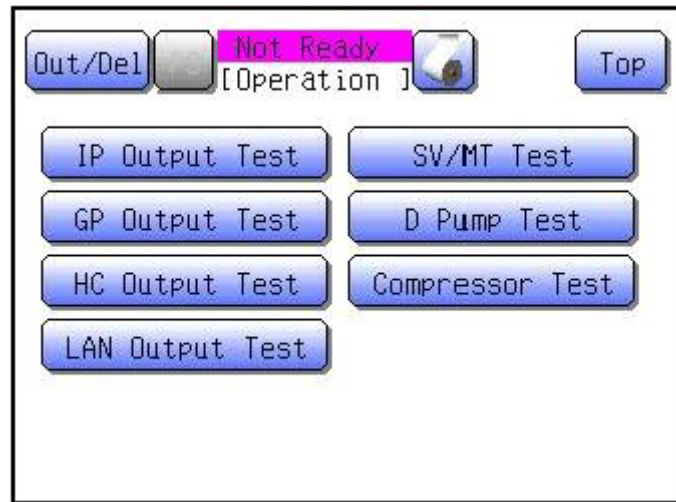

Test Operation Menu Screen

Functions of the Buttons

Buttons	Functions
[Top]	Returns to the service menu screen.
[IP Output Test]	Sends data to IP Printer for testing.
[GP Output Test]	Sends data to GP Printer for testing.
[HC Output Test]	Sends data to Host Computer (Serial) for testing.
[LAN Output Test]	Sends data to Host Computer (Ethernet) for testing.
[SV/MT Test]	Displays the SV/motor test screen.
[D Pump Test]	Displays the diaphragm pump test screen.
[Compressor Test]	Checks compressor operation.

- * When output tests are performed, test data will be sent to the specified device, but the screen will not switch to another screen.
- * If any button other than [SV/MT Test] and [D Pump Test] buttons (If [SV/MT Test] button or [D Pump Test] button is pressed, another screen will be displayed.) is pressed, other buttons cannot be selected until the applicable test operation is completed. (Those buttons will be grayed out.)

5.5.1 SV/MT Test Operation

This menu is used to test SV/motor single operation. It is also used to switch Compressor ON/OFF.



SV/MT Test Screen

Functions of the Buttons

Buttons	Functions
SV buttons	Switches SVs ON and OFF.
[TOP]	Returns to the service menu screen.

Displayed items

Items	Options
SVs	Indicate the status of 24 SVs by changing the text color. SVs that are ON are shown in red text. SVs that are OFF are shown in black text.

5.5.2 D Pump Test

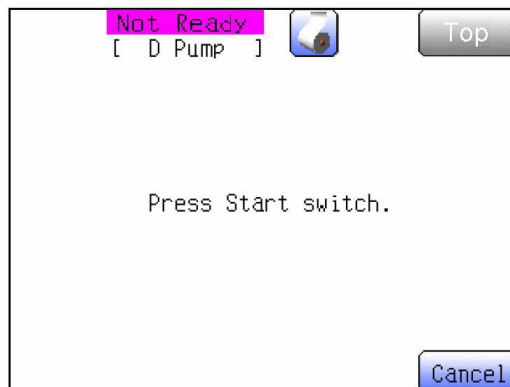

Functions of the Buttons

Buttons	Functions
Cancel	Cancel the diaphragm pump test to return to the Test Operation menu screen.

* Press the Start switch on the main unit to perform a diaphragm pump test. While the test is in progress, "Cancel" button cannot be used (The button will be grayed out).

5.5.3 HC Output Test

This function is used to send data to the host computer (serial) for testing. After data are sent, the screen will return to the Test Operation menu screen.

5.5.4 LAN Output Test

This function is used to send data to the host computer (Ethernet) for testing. After data are sent, the screen will return to the Test Operation menu screen.

5.5.5 IP Output Test

This function is used to send data to the internal printer for testing. After data are sent, the screen will return to the Test Operation menu screen.

5.5.6 GP Output Test

This function is used to send data to GP printer for testing. After data are sent, the screen will return to the Test Operation menu screen.

5.5.7 Compressor Test

This function is used to check Compressor operation.

5.6 Product Settings

This menu is used to set product settings. (This program is for production only. It is not available for use in the field.)

(* To enter the Product mode, it is necessary to enter a password.)

1. When [Product Settings] button is pressed, "Enter Password Screen" will be displayed. A

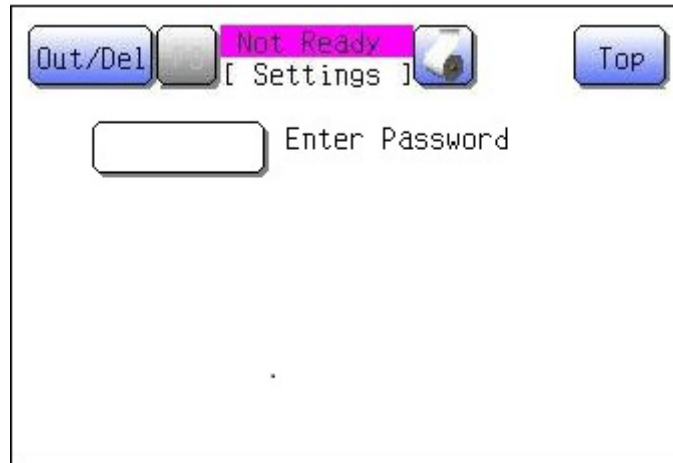

Enter Password Screen A

2. After a password is entered, "Product Settings Screen" will be displayed. A

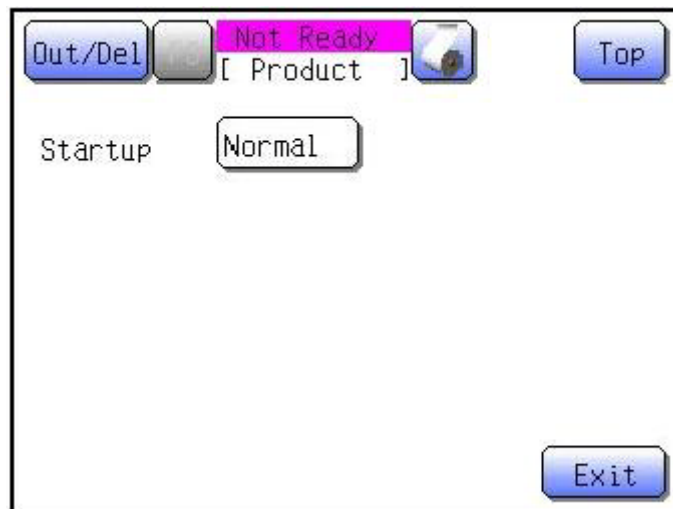

Product Settings Screen

Functions of the Buttons

Buttons	Functions
[Top]	Displays the setting cancel confirmation dialog box.
Item buttons	Display the options dialog box.
[Exit]	Displays the setting storing confirmation dialog box.

A 201297

Options

Item	Options
Startup	Normal ^{*1} / Product If user setting files for product program are not stored in the DOS domain, "Normal" will be displayed. If such files are stored, "Product" will be displayed.

*1 Default setting

5.6.1 Setting Storing Confirmation Dialog Box

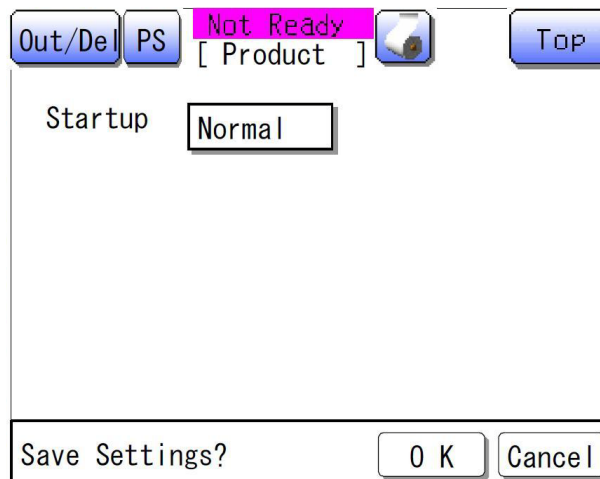

Product Program Setting Storing Confirmation Dialog Box

Functions of the Buttons

Buttons	Functions
[OK]	If the setting for "Startup" is "Normal": Deletes user setting files for product program in the DOS domain and displays the service menu screen. If the setting for "Startup" is "Product": Creates user setting files for product program (copies from BBU-RAM) in the DOS domain and displays the service menu screen.
[Cancel]	Closes the dialog box.

5.6.2 Setting Cancel Dialog Box

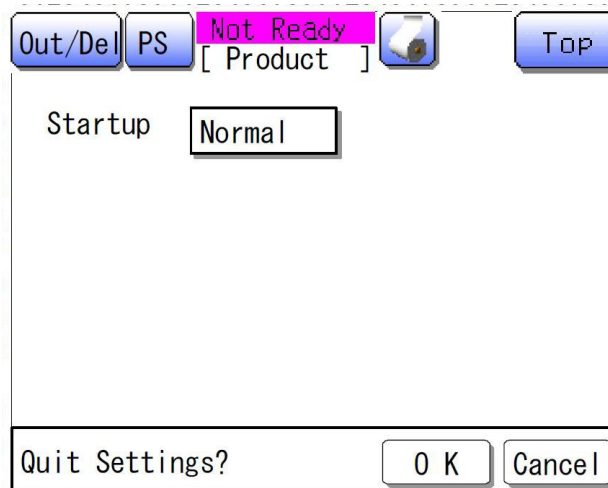

Product Program Setting Cancel Dialog Box

Functions of the Buttons

Buttons	Functions
[OK]	Closes the dialog box and displays the service menu screen.
[Cancel]	Closes the dialog box.

5.7 BBU Backup

This function is used to calculate all settings stored in the instrument (BBU RAM) and checksum of settings to write in CompactFlash.

If a backup fails, BBU Backup Error dialog box will appear.

5.7.1 BBU RAM Backup Confirmation Dialog Box

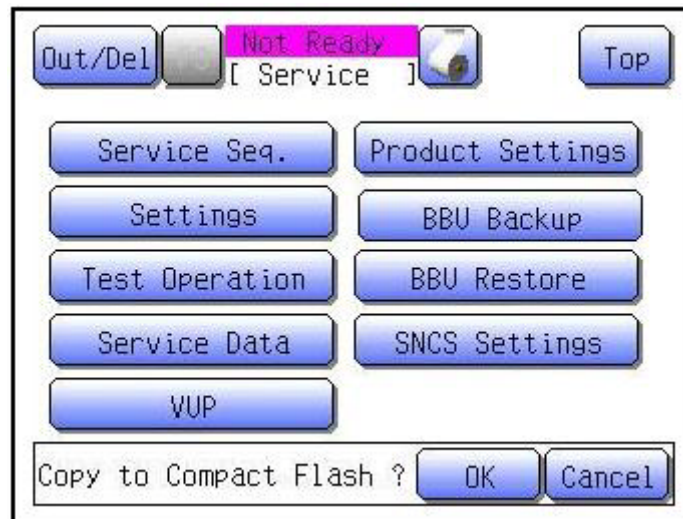

BBU RAM Backup Confirmation Dialog Box

Functions of the Buttons

Buttons	Functions
[OK]	Starts BBU RAM backup. After backup is completed, this dialog box will be closed.
[Cancel]	Closes the dialog box.

5.7.2 BBU Backup Error Dialog Box

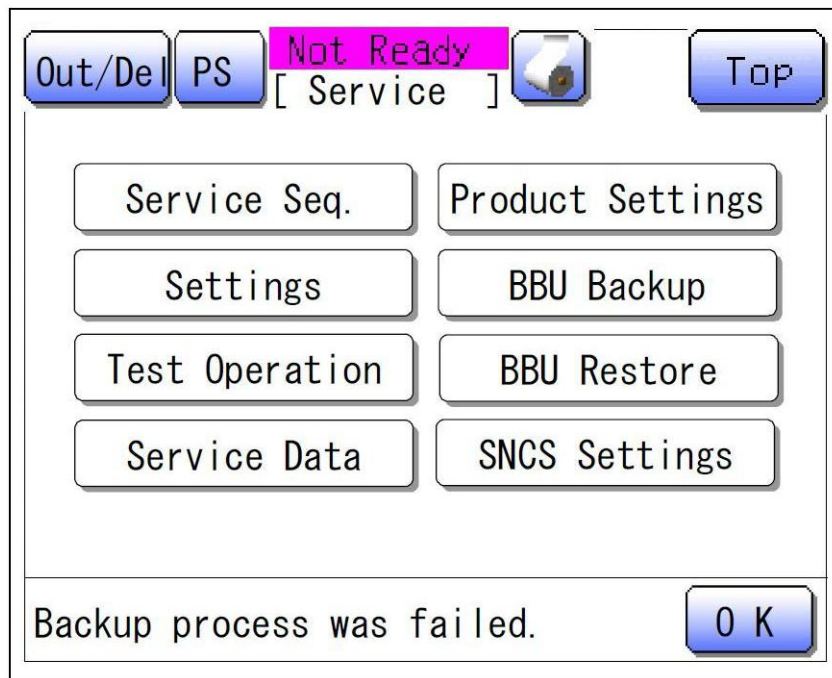

BBU Backup Error Dialog Box Screen

Functions of the Buttons

Buttons	Functions
[OK]	Cancels backup operation and closes the dialog box.
Other buttons	Disabled * Excludes PS button

5.8 BBU Restore

This function is used to bring backup data back to BBU RAM once again.

If there is no backup file, restoration will not be performed and “Restoration Error” dialog box will be displayed.

In addition, a checksum is performed on backup data. If an error is found, restoration will not be performed and the “check sum error” dialog box will be displayed.

Settings to be restored are as follows:

Items to be restored

Menu	Items to be restored
Analysis Limit	Limit (Service)
Parameters	Parameter Settings (Service)
Cycle Counter	Cycle counts, periodic maintenance data, error log, calibration history, logging data
QC Settings	QC setting files
User Settings	Customer settings (excludes time, e.g., year, month, day, hour, minute)
User Calib.	Customer calibration values (whole blood mode, diluted mode) (Only HGB, HCT, WBC, RBC and PLT are to be restored.) Service function settings and special settings
Reagent Info.	Reagent replacement log files

5.8.1 BBU Restoration Confirmation Dialog Box

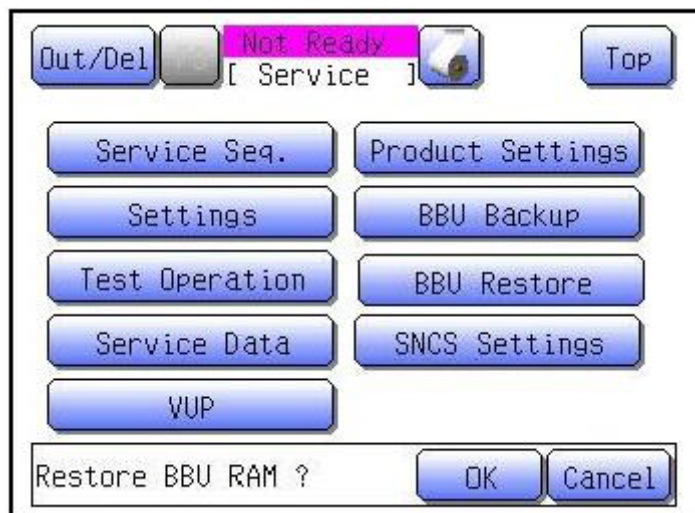

BBU Restoration Confirmation Dialog Box

Functions of the Buttons

Buttons	Functions
[OK]	Starts restoring data to BBU RAM. After restoration is completed, “Restoration Completed” screen will appear. If there is no backup file to be restored, the “Restoration Error” dialog box will appear. Performs sum check for backup data, and displays the “check sum error” dialog box if an error is found.
[Cancel]	Closes the dialog box.

5.8.2 “Restoration Error” Dialog Box

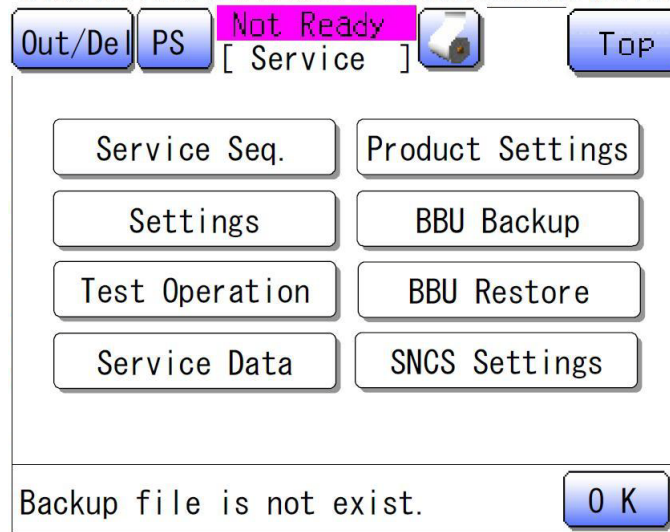

“Restoration Error” Dialog Box

Functions of the Buttons

Buttons	Functions
[OK]	Cancels restoration and closes the dialog box.

5.8.3 “Check Sum Error” Dialog Box

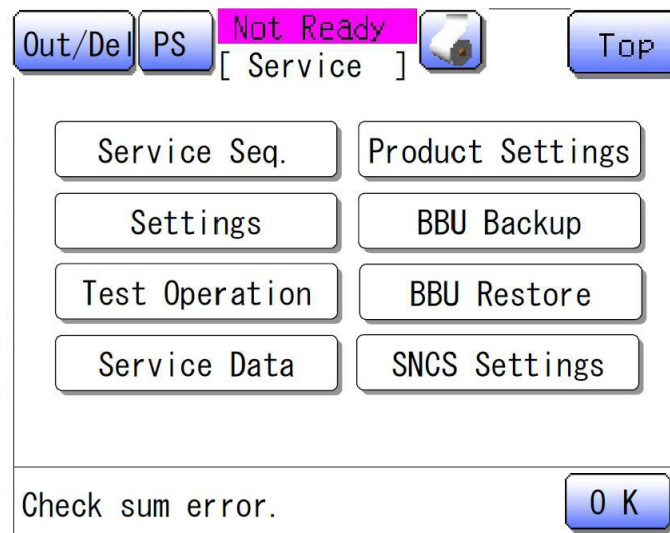

“Check Sum Error” Dialog Box

Functions of the Buttons

Buttons	Functions
[OK]	Cancels restoration and closes the dialog box.

5.8.4 “Restoration completed” Screen

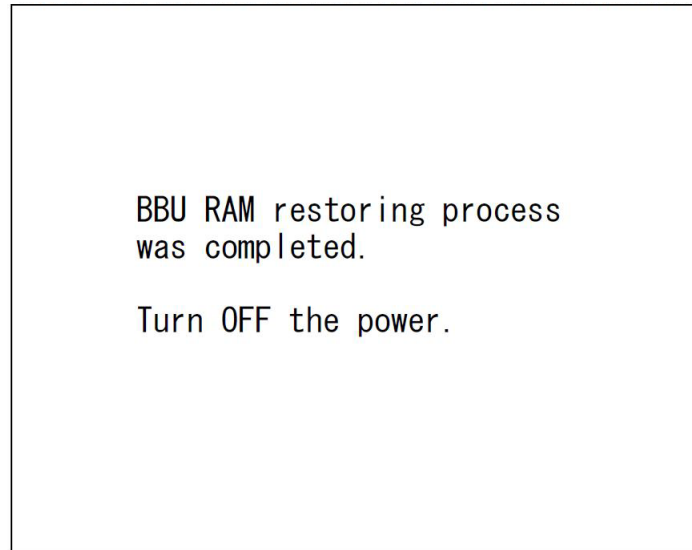

“Restoration completed” Screen

Functions of the Buttons

Buttons	Functions
All buttons	Disabled

5.8.5 Settings Backup (Reference)

1. There are 7 types of dat files to manage settings backup files.
2. When BBU Backup button is pressed or settings are changed, data will be backed up from BBU to the CF card.
3. One of SNCS functions is to backup settings, sending 7 types of dat files to the SNCS server at time of shutdown.

(1) How to restore settings

* Below is how to restore backup files backed up in the CF card on the XP instrument or settings data stored in the SNCS server.

- a) To restore data backed up in the CF card on the XP instrument
 - (1) Go to the service menu and press [BBU Restore] button.
 - (2) Switch the instrument OFF and ON to check if settings have been changed.
- b) To restore data stored in the SNCS server
 - (1) Copy 7 types of dat files from the SNCS server and save them temporarily in a medium (e.g. USB memory).
 - (2) Turn OFF the power to the XP instrument and then remove the CF card. Insert the CF card (An adapter is required.) into a PC and restore data temporarily saved in step (1) above to the CF card.
 - (3) Insert the CF card back into the XP instrument and turn ON the power to the instrument.
 - (4) Go to the service menu and press [BBU Restore] button.
 - (5) Switch the instrument OFF and ON to check if settings have been changed.

(2) Functions of CF Card

a) There are 7 types of settings backup files sent to the SNCS server.

	Classification 1	Classification 2	Descriptions
1	Periodic maintenance files (regular_value_p.dat/ regular_value_s.dat)	Status of periodic maintenance	Files storing data on periodic maintenance, such as “Clean Waste Chamber”, “Clean Transducer” and “SRV reset”.
2	Calibration value files (cariv_value_p.dat/ cariv_value_s.dat)	Calibration values	Files storing calibration settings data
3	Dilution and calibration value files (carive_val_pd_p.dat/ carive_val_pd_s.dat)	Dilution and calibration value files	Files storing dilution and calibration settings data
4	User settings files (user_value_p.dat/ user_value_s.dat)	System Date/Time Patient Limits User Information settings Quality Control Host Output Printer Network Password Setting	Files storing user settings
5	Service settings files (service_value_p.dat/ service_value_s.dat)	Calibration HardwareLimits AnalysisLimits Parameters Report Item	Files storing service settings (excluding SNCS files)
6	SNCS settings files (service_sncs_p.dat/ service_sncs_s.dat)	SNCS Settings	Files storing service (SNCS-related) settings
7	System settings files (system_value_p.dat/ system_value_s.dat)	Fixed system settings	Settings files storing necessary data in the system, such as touch panel data and program data.

b) Functions of SNCS folder

Functions of SNCS folder are as follows:

i) Location to store e-mail attachment files

When screenshots are taken, bitmap image files will be saved temporarily as there is a time lag between when screenshots are taken and when e-mails are sent.

ii) Location to save error information

Saves information on an error report sent at the same time as a shutdown report is sent.

An error report (XML) is sent by email immediately after an error occurs. However, with an error report (TEXT), all error information that occurred on the same day is sent by email at time of shutdown.

Such error information will be saved in this location.

iii) Location to store data for unsent e-mails

* All files listed above will be deleted when e-mail delivery is completed.

5.9 SNCS Settings

5.9.1 SNCS Settings Screen

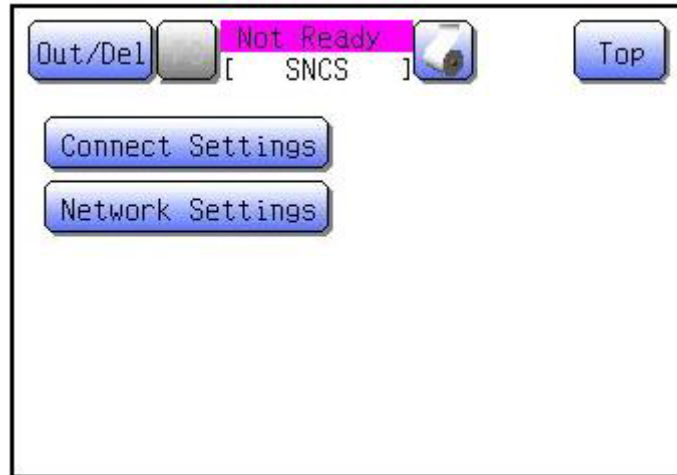

SNCS Settings Screen

Functions of the Buttons

Buttons	Functions
[Out/Del]	Displays the [Out/Del] menu.
[PS]	Captures the screenshot of the screen displayed.
(Printing paper feeder) 	Feeds printing paper.
[Top]	Displays the setting cancel confirmation dialog box.
[Connect Settings]	Displays the SNCS connection settings screen.
[Network Settings]	Displays the SNCS network settings screen.

5.9.2

SNCS Connection Settings Screen (When [Connect Settings] button is pressed)

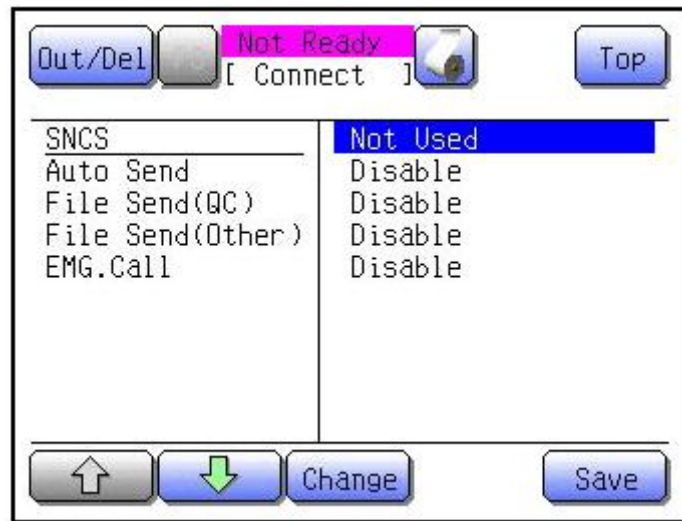

SNCS Connection Settings Screen

Functions of the Buttons

Buttons	Functions
[Top]	Displays the setting cancel confirmation dialog box.
Parameter buttons	Displays options for the respective parameters.
[↑]	Moves the cursor one position up. If the cursor is on the top parameter, the button is masked and an alarm will sound when that button is pressed.
[↓]	Moves the cursor one position down. If the cursor is on the lowermost parameter, the button is masked and an alarm will sound when that button is pressed.
[Change]	Changes the settings for the parameter on which the cursor is placed.
[Save]	Displays the setting storing confirmation dialog box.

Options

Items	Options
SNCS	Settings on use of SNCS functions Options (Not Used ^{*1} /Used)
Auto Send	Settings on data to be sent automatically Options (Disable ^{*1} /QCdata/Mainte.report/All)
File Send(QC)	Settings on manual delivery of QC data Options (Disable ^{*1} /Enable) If set at "Disable", [File Send] button will be masked in the QC screen.
File Send(Other)	Settings on manual delivery of maintenance data and image data Options (Disable ^{*1} /Image//Mainte.reort/All) If set at "Disable", [File Send] button will be masked on screens other than the QC screen.
EMG.Call	Options (Disable ^{*1} / Enable) If set at "Disable", [EMG.Cal] button will be masked.

*1 Default setting

5.9.3

SNCS Network Settings Selection Screen (When [Network Settings] is pressed)

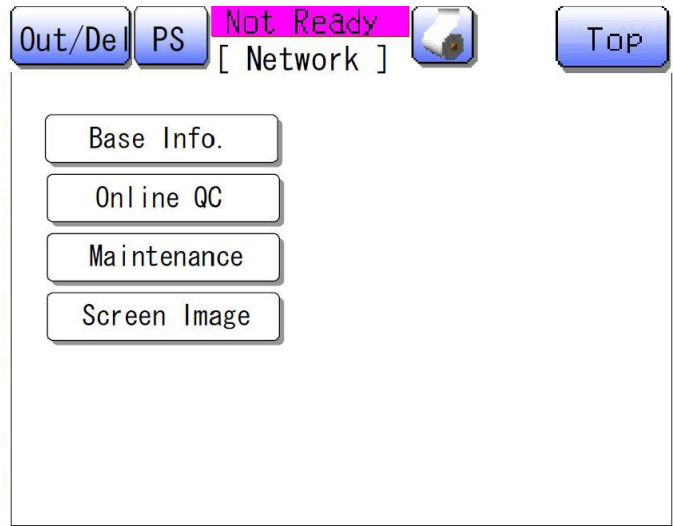

SNCS Network Settings Selection Screen

Functions of the Buttons

Buttons	Functions
[Out/Del]	Displays [Out/Del] menu.
[PS]	Captures the screenshot of the screen displayed
(Printing paper feeder) 	Feeds printing paper.
[Top]	Displays the setting cancel confirmation dialog box.
[Base Info.]	Displays the [Base Info.] settings screen.
[Online QC]	Displays the [Online QC] settings screen.
[Maintenance]	Displays the [Maintenance] settings screen.
[Screen Image]	Displays the [Screen Image] settings screen.

5.9.4 SNCS Network Settings Screen

Out/Del	PS	Not Ready		Top
[SNCS]				
DHCP	Used			
IP Address				
GW Address	XXX.XXX.XXX.XXX			
Subnet Mask	XXX.XXX.XXX.XXX			
Primary DNS	XXX.XXX.XXX.XXX			
Secondary DNS	XXX.XXX.XXX.XXX			
DialUp Timer	30			
Time Zone	GMP+09:00			
Serial No.	12345			
		Change	Save	

SNCS Network Settings Screen (When Base Info. is selected)

Functions of the Buttons

Buttons	Functions
[Out/Del]	Displays the [Out/Del] menu.
[PS]	Captures the screenshot of the screen displayed
(Printing paper feeder)	Feeds printing paper.
[Top]	Displays the setting cancel confirmation dialog box.
[↑]	Moves the cursor one position up. If the cursor is on the top parameter, the button is masked and an alarm will sound, preventing the cursor from moving.
[↓]	Moves the cursor one position down. If the cursor is on the lowermost parameter, the button is masked and an alarm will sound, preventing the cursor from moving.
[Change]	Changes the settings for the parameter on which the cursor is placed. <ul style="list-style-type: none"> • For “Used/Not Used”, change settings by pressing “Change” button. • If a parameter which requires a value to be entered is selected, the setting input screen will open.
[Save]	Displays the setting storing confirmation dialog box.

List of parameter items displayed when [Base Info.] button is pressed A

Items	Default values	Descriptions	Input Range
DHCP	Not Used	DHCP server setting	Used / Not used
IP Address	192.168.0.1	IP address when DHCP is not used Format: "ddd.ddd.ddd.ddd"	Only numerical values can be entered 0~255
GW Address	0.0.0.0	Gateway address when DHCP is not used Format: "ddd.ddd.ddd.ddd"	Only numerical values can be entered 0~255
Subnet Mask	255.255.255.0	Subnet mask when DHCP is not used (Follows SNCS ID registration form)	Only numerical values can be entered 0~255
Primary DNS	0.0.0.0	Primary DNS server address when DHCP is not used (IP address for routers)	Only numerical values can be entered 0~255
Secondary DNS	0.0.0.0	Secondary DNS server address when DHCP is not used	Only numerical values can be entered 0~255
DialUp Timer	30 seconds	Timeout (3 ~ 120 seconds)	3 ~ 120 seconds
Time Zone	GMT+09:00	Registers the time zone	GMT+/GMT- Time: 00:00~23:59
Serial No.	00000	The instrument's serial number	Alphanumeric characters (Up to 5 digits)
RMTSETUP	Not Used	Whether remote setup function is used or not used	"Not used" only
My Mail Address	sysmex00001	Sender's e-mail address (Alphanumeric characters entered before "@")	Alphanumeric characters, ".", "-", "_" Up to 28 characters
	sncs.sysmex.co.jp	Sender's e-mail address (Alphanumeric characters entered after "@")	Alphanumeric characters, ".", "-", "_" Up to 28 characters

A Red text refers to changes made according to ECR 312I034.

List of parameters displayed when [Online QC] button is pressed A B

Items	Default values	Descriptions	Input Range
Subject	QC DATA	To specify the title of e-mail	Alphanumeric characters, "-", "_", ".", space Up to 15 characters
Server Name	sncs.sismex.co.jp	To specify the name or IP address (ddd.ddd.ddd.ddd) of e-mail server.	Alphanumeric characters, ".", "-", "_" Up to 28 characters
Server Port	25	To set e-mail server port number.	1 ~ 65535
Authentication	Disable	To specify authentication method (Disable/POP/SMTP(LOGIN)/SMTP(PLAIN))	Disable/POP/SMTP(LOGIN)/SMTP(PLAIN)
Auth Server Name	sncs.sismex.co.jp	To specify the name or IP address of authentication server (ddd.ddd.ddd.ddd). - POP authentication: POP server name - SMTP (LOGIN) authentication: Not Used (*1) - SMTP(PLAIN) authentication: Not Used (*1) (*1) As authentication server is the same as e-mail server, the name or IP address of e-mail server is used.	Alphanumeric characters, ".", "-", "_" Up to 28 characters
Auth Server Port	110	To specify authentication server port number. - POP authentication: POP server port number - SMTP (LOGIN) authentication: Not Used (*2) - SMTP(PLAIN) authentication: Not Used (*2) (*2) As authentication server is the same as e-mail server, e-mail server port number is used.	1 ~ 65535
Auth User Name	None	To specify user name for authentication	Alphanumeric characters, "-", ".", "_", "@" Up to 50 characters
Auth Password	None	To specify password for authentication	Alphanumeric characters, "-", "_" Up to 15 characters
To Mail Address	datareceiver@olqc.sismex.co.jp	Destination e-mail address	Alphanumeric characters, ".", "-", "_" Up to 28 characters

A Red text refers to changes made according to ECR 312I034. B 313C031

List of parameters displayed when [Maintenance] button is pressed A B

Items	Default values	Descriptions	Input Range
Server Name	sncs.sysmex.co.jp	To specify the name or IP address (ddd.ddd.ddd.ddd) of e-mail server.	Alphanumeric characters, ".", "-", "_" Up to 28 characters
Server Port	25	To set e-mail server port number.	1 ~ 65535
Authentication	Disable	To specify authentication method (Disable/POP/SMTP(LOGIN)/SMTP(PLAIN))	Disable/POP/SMTP(LOGIN)/SMTP(PLAIN)
Auth Server Name	sncs.sysmex.co.jp	To specify the name or IP address (ddd.ddd.ddd.ddd) of authentication server. - POP authentication: POP server name - SMTP (LOGIN) authentication: Not Used (*1) - SMTP(PLAIN) authentication: Not Used (*1) (*1) As authentication server is the same as e-mail server, the name or IP address of e-mail server is used.	Alphanumeric characters, ".", "-", "_" Up to 28 characters
Auth Server Port	110	To specify authentication server port number. - POP authentication: POP server port number - SMTP (LOGIN) authentication: Not Used (*2) - SMTP(PLAIN) authentication: Not Used (*2) (*2) As authentication server is the same as e-mail server, e-mail server port number is used.	1 ~ 65535
Auth User Name	None	To specify user name for authentication	Alphanumeric characters, ".", "-", "_", "@" Up to 50 characters
Auth Password	None	To specify password for authentication	Alphanumeric characters, "-", "_" Up to 15 characters
To Mail Address	sysmex-log@sncs.sysmex.co.jp	Destination e-mail address	Alphanumeric characters, ".", "-", "_" Up to 28 characters

B 313C031

List of parameters displayed when [Screen Image] button is pressed A B

Items	Default values	Descriptions	Input Range
Server Name	sncs.sysmex.co.jp	To specify the name or IP address (ddd.ddd.ddd.ddd) of e-mail server.	Alphanumeric characters, ".", "-", "_" Up to 28 characters
Server Port	25	To set e-mail server port number.	1 ~ 65535
Authentication	Disable	To specify authentication method (Disable/ POP/ SMTP(LOGIN)/ SMTP(PLAIN))	Disable/ POP/ SMTP(LOGIN)/ SMTP(PLAIN)
Auth Server Name	sncs.sysmex.co.jp	To specify the name or IP address (ddd.ddd.ddd.ddd) of authentication server. - POP authentication: POP server name - SMTP (LOGIN) authentication: Not Used (*1) - SMTP(PLAIN) authentication: Not Used (*1) (*1) As authentication server is the same as e-mail server, the name or IP address of e-mail server is used.	Alphanumeric characters, ".", "-", "_" Up to 28 characters
Auth Server Port	110	To specify authentication server port number. - POP authentication: POP server port number - SMTP (LOGIN) authentication: Not Used (*2) - SMTP(PLAIN) authentication: Not Used (*2) (*2) As authentication server is the same as e-mail server, e-mail server port number is used.	1 ~ 65535
Auth User Name	None	To specify user name for authentication	Alphanumeric characters, "-", ".", "_", "@" Up to 50 characters
Auth Password	None	To specify password for authentication	Alphanumeric characters, "-", "_" Up to 15 characters
To Mail Address	sysmex-tsc01@sncs.sysmex.co.jp	Destination e-mail address	Alphanumeric characters, ".", "-", "_" Up to 28 characters

A Red text refers to changes made according to ECR 312I034. B 313C031

5.9.5 SNCS Network Individual Settings Screen

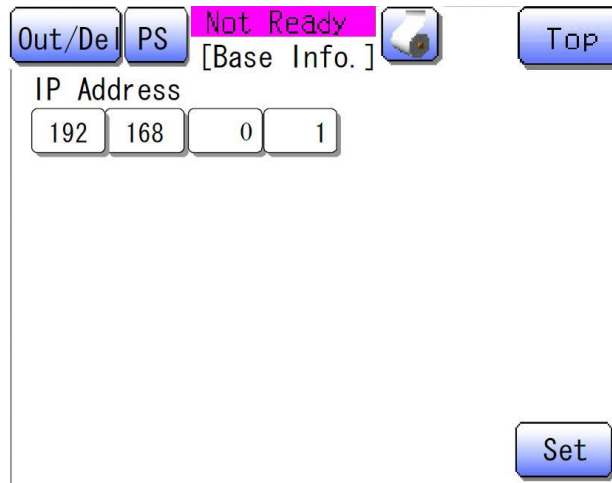

SNCS Network Individual Settings Screen (When "IP Address" is selected)

Functions of the Buttons

Buttons	Functions
[Out/Del]	Displays the [Out/Del] menu.
[PS]	Captures the screenshot of the screen displayed
(Printing paper feeder) 	Feeds printing paper.
[Top]	Displays the setting cancel confirmation dialog box.
Input items	When one of the input item buttons is pressed, a numeric keypad will be displayed to suit the format of a value to be entered.
[Set]	Sets the input value. The value will be saved by pressing the [Save] button on the list of settings screen.

5.9.6 Setting Cancel Confirmation Dialog Box

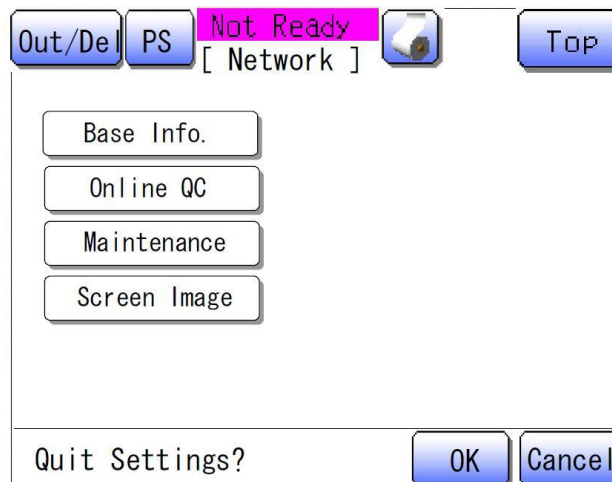

Functions of the Buttons

Buttons	Functions
[OK]	Displays the service menu screen.
[Cancel]	Closes the dialog box.
Other buttons	Disabled * Excludes PS button

5.9.7 Setting Storing Confirmation Dialog Box

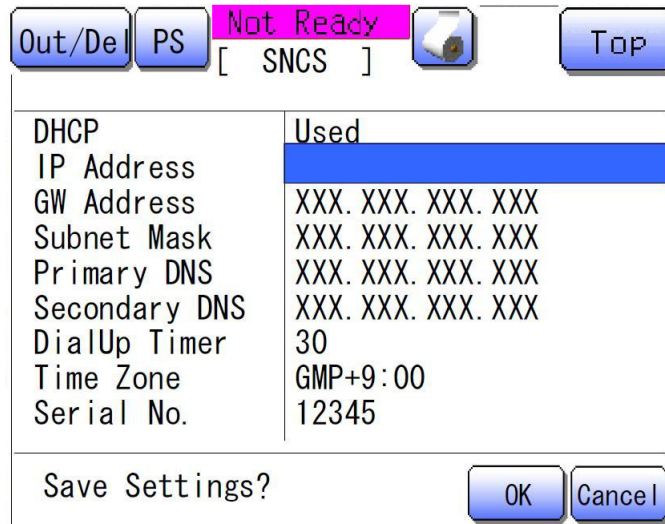

Functions of the Buttons

Buttons	Functions
[OK]	Displays the service menu screen after saving settings.
[Cancel]	Closes the dialog box.
Other buttons	Disabled * Excludes PS button

NOTE:

For SNCS settings, refer to SNCS Service Manual, "2.5.3 IPU - SNCS Router Communication Settings".

5.10 Service Settings (List of Default Values)

Item Name		Default Value	For Japan (100V)	For Europe XP100 (230V)	For Europe XP300 (230V)	For the UK XP100 (240V)	For the UK XP300 (240V)
Parameters	CALIBRATOR	Not Used	Not Used	Not Used	Not Used	Not Used	Not Used
	PDW,P-LCR	Used	Used	Used	Used	Used	Used
	PCT	Used	Used	Used	Used	Used	Used
	PS CODE	XP-300: BL783052	XP-300: BL783052	XP-100: BS649542	XP-300: AP807129	XP-100: AQ088754	XP-300: AJ213506
	RAW DATA	Not Saved	Not Saved	Not Saved	Not Saved	Not Saved	Not Saved
	ISBTstart	1	1	1	1	1	1
	ISBTend	13	13	13	13	13	13
	OPERATOR	Used	Used	Used	Used	Used	Used
	ASTM QC Out	QC File	QC File	QC File	QC File	QC File	QC File
	RESWARCH W	Used	Used	Used	Used	Used	Used
CELLPACK	CELLPACK	CELLPACK	CELLPACK	CELLPACK	CELLPACK	CELLPACK	
Discrete	WBC	8	8	8	8	8	8
	RBC	8	8	8	8	8	8
	PLT	1	1	1	1	1	1
	-	0	0	0	0	0	0
Calib.(WB)	WBC	100.0	100.0	100.0	100.0	100.0	100.0
	RBC	100.0	100.0	100.0	100.0	100.0	100.0
	HGB	100.0	100.0	100.0	100.0	100.0	100.0
	RBC GAIN	100.0	100.0	100.0	100.0	100.0	100.0
	PLT	100.0	100.0	100.0	100.0	100.0	100.0
	W-SCR	100.0	100.0	100.0	100.0	100.0	100.0
	W-MCR	100.0	100.0	100.0	100.0	100.0	100.0
	RDW-SD	100.0	100.0	100.0	100.0	100.0	100.0
	RDW-CV	100.0	100.0	100.0	100.0	100.0	100.0
	PDW	100.0	100.0	100.0	100.0	100.0	100.0
	MPV	100.0	100.0	100.0	100.0	100.0	100.0
	P-LCR	100.0	100.0	100.0	100.0	100.0	100.0
	PCT	100.0	100.0	100.0	100.0	100.0	100.0
Calib.(PD)	WBC(P)	100.0	100.0	100.0	100.0	100.0	100.0
	RBC(P)	100.0	100.0	100.0	100.0	100.0	100.0
	HGB(P)	100.0	100.0	100.0	100.0	100.0	100.0
	RBC GAIN (P)	100.0	100.0	100.0	100.0	100.0	100.0
	PLT(P)	100.0	100.0	100.0	100.0	100.0	100.0
	W-SCR(P)	100.0	100.0	100.0	100.0	100.0	100.0
	W-MCR(P)	100.0	100.0	100.0	100.0	100.0	100.0
	RDW-SD(P)	100.0	100.0	100.0	100.0	100.0	100.0
	RDW-CV(P)	100.0	100.0	100.0	100.0	100.0	100.0
	PDW(P)	100.0	100.0	100.0	100.0	100.0	100.0
	MPV(P)	100.0	100.0	100.0	100.0	100.0	100.0
	P-LCR(P)	100.0	100.0	100.0	100.0	100.0	100.0
	PCT(P)	100.0	100.0	100.0	100.0	100.0	100.0
Calib.(SENSE)	WBC-SENS	125	125	125	125	125	125
	RBC-SENS	64	64	64	64	64	64

Item Name		Default Value	For Japan (100V)	For Europe XP100 (230V)	For Europe XP300 (230V)	For the UK XP100 (240V)	For the UK XP300 (240V)
H/W Limit	PRESS SL	0.0390	0.0390	0.0390	0.0390	0.0390	0.0390
	PRESS SH	0.0590	0.0590	0.0590	0.0590	0.0590	0.0590
	PRESS ML	0.0290	0.0290	0.0290	0.0290	0.0290	0.0290
	PRESS MH	0.0590	0.0590	0.0590	0.0590	0.0590	0.0590
	PRESS RL	0.0200	0.0200	0.0200	0.0200	0.0200	0.0200
	VAC SL	0.0307	0.0307	0.0307	0.0307	0.0307	0.0307
	VAC SH	0.0360	0.0360	0.0360	0.0360	0.0360	0.0360
	VAC ML	0.0134	0.0134	0.0134	0.0134	0.0134	0.0134
	VAC MH	0.0360	0.0360	0.0360	0.0360	0.0360	0.0360
	RES L	80	80	80	80	80	80
	RES H	125	125	125	125	125	125
	WH LIMIT	95	95	95	95	95	95
	TEMP H	40.0	40.0	40.0	40.0	40.0	40.0
	TEMP L	10.0	10.0	10.0	10.0	10.0	10.0
	WC PERIOD	30	30	30	30	30	30
WC COUNT	1500	1500	1500	1500	1500	1500	
TD PERIOD	30	30	30	30	30	30	
H/W Limit	TD COUNT	1500	1500	1500	1500	1500	1500
	SLEEP TMR	15	15	15	15	15	15
	SRV PERIOD	90	90	90	90	90	90
	SRV COUNT	4500	4500	4500	4500	4500	4500
Ana. Limit	BLANK W	3	3	3	3	3	3
	BLANK R	2	2	2	2	2	2
	BLANK P	10	10	10	10	10	10
	BLANK H	1	1	1	1	1	1
	CLOG W	120	120	120	120	120	120
	CLOG R	120	120	120	120	120	120
	AG LIMIT	200	200	200	200	200	200
	WL MASK	95	95	95	95	95	95
	PL LMT	10	10	10	10	10	10
	SMP LMT W	2.0	2.0	2.0	2.0	2.0	2.0
	SMP LMT R	2.0	2.0	2.0	2.0	2.0	2.0
	SMP LMT P	2.0	2.0	2.0	2.0	2.0	2.0
	SMP OFF W	200	200	200	200	200	200
	SMP OFF R	1250	1250	1250	1250	1250	1250
SMP OFF P	100	100	100	100	100	100	

Item Name		Default Value	For Japan (100V)	For Europe XP100 (230V)	For Europe XP300 (230V)	For the UK XP100 (240V)	For the UK XP300 (240V)
Report Item	WBC	Result	ON	ON	ON	ON	ON
		Stored	ON	ON	ON	ON	ON
		IP	ON	ON	ON	ON	ON
	RBC	Result	ON	ON	ON	ON	ON
		Stored	ON	ON	ON	ON	ON
		IP	ON	ON	ON	ON	ON
	HGB	Result	ON	ON	ON	ON	ON
		Stored	ON	ON	ON	ON	ON
		IP	ON	ON	ON	ON	ON
	HCT	Result	ON	ON	ON	ON	ON
		Stored	ON	ON	ON	ON	ON
		IP	ON	ON	ON	ON	ON
	PLT	Result	ON	ON	ON	ON	ON
		Stored	ON	ON	ON	ON	ON
		IP	ON	ON	ON	ON	ON
	MCV	Result	ON	ON	ON	ON	ON
		Stored	ON	ON	ON	ON	ON
		IP	ON	ON	ON	ON	ON
	MCH	Result	ON	ON	ON	ON	ON
		Stored	ON	ON	ON	ON	ON
		IP	ON	ON	ON	ON	ON
	MCHC	Result	ON	ON	ON	ON	ON
		Stored	ON	ON	ON	ON	ON
		IP	ON	ON	ON	ON	ON
	W-SCR	Result	ON	ON	ON	ON	ON
		Stored	ON	ON	ON	ON	ON
		IP	ON	ON	ON	ON	ON
	W-MCR	Result	ON	ON	ON	ON	ON
		Stored	ON	ON	ON	ON	ON
		IP	ON	ON	ON	ON	ON
	W-LCR	Result	ON	ON	ON	ON	ON
		Stored	ON	ON	ON	ON	ON
		IP	ON	ON	ON	ON	ON
	W-SCC	Result	ON	ON	ON	ON	ON
		Stored	ON	ON	ON	ON	ON
		IP	ON	ON	ON	ON	ON
	W-MCC	Result	ON	ON	ON	ON	ON
		Stored	ON	ON	ON	ON	ON
		IP	ON	ON	ON	ON	ON
	W-LCC	Result	ON	ON	ON	ON	ON
		Stored	ON	ON	ON	ON	ON
		IP	ON	ON	ON	ON	ON
	RDW-SD	Result	ON	ON	ON	ON	ON
		Stored	ON	ON	ON	ON	ON
		IP	ON	ON	ON	ON	ON
	RDW-CV	Result	ON	ON	ON	ON	ON
		Stored	ON	ON	ON	ON	ON
		IP	ON	ON	ON	ON	ON
PDW	Result	ON	ON	ON	ON	ON	
	Stored	ON	ON	ON	ON	ON	
	IP	ON	ON	ON	ON	ON	
MPV	Result	ON	ON	ON	ON	ON	
	Stored	ON	ON	ON	ON	ON	
	IP	ON	ON	ON	ON	ON	
P-LCR	Result	ON	ON	ON	ON	ON	
	Stored	ON	ON	ON	ON	ON	
	IP	ON	ON	ON	ON	ON	
PCT	Result	ON	ON	ON	ON	ON	
	Stored	ON	ON	ON	ON	ON	
	IP	ON	ON	ON	ON	ON	

Item Name		Default Value	For Japan (100V)	For Europe XP100 (230V)	For Europe XP300 (230V)	For the UK XP100 (240V)	For the UK XP300 (240V)
SNCS (For the UK) A	Connection Settings	SNCS	UnUsed(0)	UnUsed(0)	UnUsed(0)	UnUsed(0)	UnUsed(0)
		Auto Send	Disable(0)	Disable(0)	Disable(0)	Disable(0)	Disable(0)
		File Send(QC)	Disable(0)	Disable(0)	Disable(0)	Disable(0)	Disable(0)
		File Send (other)	Disable(0)	Disable(0)	Disable(0)	Disable(0)	Disable(0)
		S. Call	Disable(0)	Disable(0)	Disable(0)	Disable(0)	Disable(0)
	Network Settings (Basic Information)	DHCP	Not Used(0)	Not Used(0)	Not Used(0)	Not Used(0)	Not Used(0)
		IP Address	192.168.0.1	192.168.0.1	192.168.0.1	192.168.0.1	192.168.0.1
		GW Address	0.0.0.0	0.0.0.0	0.0.0.0	0.0.0.0	0.0.0.0
		Subnet Mask	255.255.255.0	255.255.255.0	255.255.255.0	255.255.255.0	255.255.255.0
		Primary DNS	0.0.0.0	0.0.0.0	0.0.0.0	0.0.0.0	0.0.0.0
		Secondary DNS	0.0.0.0	0.0.0.0	0.0.0.0	0.0.0.0	0.0.0.0
		DialUp Timer	30	30	30	30	30
		TimeZone	GMT+09:00	GMT+09:00	GMT+09:00	GMT+09:00	GMT+09:00
		Serial No	00000	00000	00000	00000	00000
		My Mail Address	sysmex00001@sncs.sysmex.co.jp	sysmex00001@sncs.sysmex.co.jp	sysmex00001@sncs.sysmex.co.jp	sysmex00001@sncs.sysmex.co.jp	sysmex00001@sncs.sysmex.co.jp
		RMTSETUP	Not Used(0)	Not Used(0)	Not Used(0)	Not Used(0)	Not Used(0)
	Network Settings (QC Data)	Server Name	sncs.sysmex.co.jp	sncs.sysmex.co.jp	sncs.sysmex.co.jp	sncs.sysmex.co.jp	sncs.sysmex.co.jp
		Server Name Port	25	25	25	25	25
		Authentication	Disable(0)	Disable(0)	Disable(0)	Disable(0)	Disable(0)
		Auth Server Name	sncs.sysmex.co.jp	sncs.sysmex.co.jp	sncs.sysmex.co.jp	sncs.sysmex.co.jp	sncs.sysmex.co.jp
		Auth Server Port	110	110	110	110	110
		Auth User Name	None	None	None	None	None
		Auth Password	None	None	None	None	None
		To Mail Address	datareceiver@olqc.sysmex.co.jp	datareceiver@olqc.sysmex.co.jp	datareceiver@olqc.sysmex.co.jp	datareceiver@olqc.sysmex.co.jp	datareceiver@olqc.sysmex.co.jp
		Subject	QC DATA	QC DATA	QC DATA	QC DATA	QC DATA
	Network Settings (Maintenance Data)	Server Name	sncs.sysmex.co.jp	sncs.sysmex.co.jp	sncs.sysmex.co.jp	sncs.sysmex.co.jp	sncs.sysmex.co.jp
		Server Name Port	25	25	25	25	25
		Authentication	Disable(0)	Disable(0)	Disable(0)	Disable(0)	Disable(0)
		Auth Server Name	sncs.sysmex.co.jp	sncs.sysmex.co.jp	sncs.sysmex.co.jp	sncs.sysmex.co.jp	sncs.sysmex.co.jp
		Auth Server Port	110	110	110	110	110
		Auth User Name	None	None	None	None	None
		Auth Password	None	None	None	None	None
		To Mail Address	sysmex-log@sncs.sysmex.co.jp	sysmex-log@sncs.sysmex.co.jp	sysmex-log@sncs.sysmex.co.jp	sysmex-log@sncs.sysmex.co.jp	sysmex-log@sncs.sysmex.co.jp
	Network Settings (Screen Image)	Server Name	sncs.sysmex.co.jp	sncs.sysmex.co.jp	sncs.sysmex.co.jp	sncs.sysmex.co.jp	sncs.sysmex.co.jp
		Server Name Port	25	25	25	25	25
		Authentication	Disable(0)	Disable(0)	Disable(0)	Disable(0)	Disable(0)
		Auth Server Name	sncs.sysmex.co.jp	sncs.sysmex.co.jp	sncs.sysmex.co.jp	sncs.sysmex.co.jp	sncs.sysmex.co.jp
		Auth Server Port	110	110	110	110	110

A 313C031

Item Name		Default Value	For Japan (100V)	For Europe XP100 (230V)	For Europe XP300 (230V)	For the UK XP100 (240V)	For the UK XP300 (240V)
SNCS (For the UK) A	Auth User Name	None	None	None	None	None	None
	Auth Password	None	None	None	None	None	None
	To Mail Address	sysmex-tsc01@sncs.s ysmex.co.jp	sysmex-tsc01@sncs.s ysmex.co.jp	sysmex-tsc01@sncs.s ysmex.co.jp	sysmex-tsc01@sncs.s ysmex.co.jp	sysmex-tsc01@sncs.s ysmex.co.jp	sysmex-tsc01@sncs.s ysmex.co.jp
Special Settings	R.Barcode	Used	Used	Used	Used	Used	Used
	Machine	XP300	XP300	XP100	XP300	XP100	XP300
	PD mode	20param	20param	20param	20param	20param	20param

(to be continued)

(Continued)

Item Name		For Overseas (120V) * Settings for North America	For China XP100(220V)	For China XP300(220V)	Remarks	Initialize
Parameters	CALIBRATOR	Used	Not Used	Not Used		Parameters
	PDW,P-LCR	Not Used	Used	Used		
	PCT	Not Used	Used	Used		
	PS CODE	XP-300: AR408878	XP-100: BN167486	XP-300: BG491812		
	RAW DATA	Not Saved	Not Saved	Not Saved		
	ISBTstart	1	1	1		
	ISBTend	13	13	13		
	OPERATOR	Used	Used	Used		
	ASTM QC Out	QC File	QC File	QC File		
RESWARCH W	Not Used	Used	Used			
CELLPACK	CELLPACK	CELLPACK	CELLPACK	Changed from Poch-Pack		
Discrete	WBC	8	8	8	No setting screen available	-
	RBC	8	8	8	No setting screen available	-
	PLT	1	1	1	No setting screen available	-
	-	0	0	0	No setting screen available	-
Calib.(WB)	WBC	100.0	100.0	100.0		Calibration
	RBC	100.0	100.0	100.0		
	HGB	100.0	100.0	100.0		
	RBC GAIN	100.0	100.0	100.0		
	PLT	100.0	100.0	100.0		
	W-SCR	100.0	100.0	100.0		
	W-MCR	100.0	100.0	100.0		
	RDW-SD	100.0	100.0	100.0		
	RDW-CV	100.0	100.0	100.0		
	PDW	100.0	100.0	100.0		
	MPV	100.0	100.0	100.0		
	P-LCR	100.0	100.0	100.0		
PCT	100.0	100.0	100.0			

A 313C031

Item Name		For Overseas (120V) * Settings for North America	For China XP100(220V)	For China XP300(220V)	Remarks	Initialize
Calib.(PD)	WBC(P)	100.0	100.0	100.0		Calibration
	RBC(P)	100.0	100.0	100.0		
	HGB(P)	100.0	100.0	100.0		
	RBC GAIN (P)	100.0	100.0	100.0		
	PLT(P)	100.0	100.0	100.0		
	W-SCR(P)	100.0	100.0	100.0		
	W-MCR(P)	100.0	100.0	100.0		
	RDW-SD(P)	100.0	100.0	100.0		
	RDW-CV(P)	100.0	100.0	100.0		
	PDW(P)	100.0	100.0	100.0		
	MPV(P)	100.0	100.0	100.0		
	P-LCR(P)	100.0	100.0	100.0		
PCT(P)	100.0	100.0	100.0			
Calib.(SENSE)	WBC-SENS	125	125	125		Calibration
	RBC-SENS	64	64	64		
H/W Limit	PRESS SL	0.0390	0.0390	0.0390		Hardware Limit
	PRESS SH	0.0590	0.0590	0.0590		
	PRESS ML	0.0290	0.0290	0.0290		
	PRESS MH	0.0590	0.0590	0.0590		
	PRESS RL	0.0200	0.0200	0.0200		
	VAC SL	0.0307	0.0307	0.0307		
	VAC SH	0.0360	0.0360	0.0360		
	VAC ML	0.0134	0.0134	0.0134		
	VAC MH	0.0360	0.0360	0.0360		
	RES L	80	80	80		
	RES H	125	125	125		
	WH LIMIT	95	95	95		
	TEMP H	40.0	40.0	40.0		
	TEMP L	10.0	10.0	10.0		
	WC PERIOD	30	30	30		
	WC COUNT	1500	1500	1500		
	TD PERIOD	30	30	30		
	TD COUNT	1500	1500	1500		
SLEEP TMR	15	15	15			
SRV PERIOD	90	90	90			
SRV COUNT	4500	4500	4500			
Ana. Limit	BLANK W	3	3	3	Unit: 10 ² /uL	Analysis Limit
	BLANK R	2	2	2	Unit: 10 ⁴ /uL	
	BLANK P	10	10	10	Unit: 10 ³ /uL	
	BLANK H	1	1	1	Unit: 10 ⁻¹ g/dl	
	CLOG W	120	120	120		
	CLOG R	120	120	120		
	AG LIMIT	200	200	200		
	WL MASK	95	95	95		
	PL LMT	10	10	10	Unit: %	
	SMP LMT W	2.0	2.0	2.0		
	SMP LMT R	2.0	2.0	2.0		
	SMP LMT P	2.0	2.0	2.0		
	SMP OFF W	200	200	200		
	SMP OFF R	1250	1250	1250		
SMP OFF P	100	100	100			

Item Name		For Overseas (120V) * Settings for North America	For China XP100(220V)	For China XP300(220V)	Remarks	Initialize
Report Item	WBC	Result	ON	ON	ON	ReportItem
		Stored	ON	ON	ON	
		IP	ON	ON	ON	
	RBC	Result	ON	ON	ON	
		Stored	ON	ON	ON	
		IP	ON	ON	ON	
	HGB	Result	ON	ON	ON	
		Stored	ON	ON	ON	
		IP	ON	ON	ON	
	HCT	Result	ON	ON	ON	
		Stored	ON	ON	ON	
		IP	ON	ON	ON	
	PLT	Result	ON	ON	ON	
		Stored	ON	ON	ON	
		IP	ON	ON	ON	
	MCV	Result	ON	ON	ON	
		Stored	ON	ON	ON	
		IP	ON	ON	ON	
	MCH	Result	ON	ON	ON	
		Stored	ON	ON	ON	
		IP	ON	ON	ON	
	MCHC	Result	ON	ON	ON	
		Stored	ON	ON	ON	
		IP	ON	ON	ON	
	W-SCR	Result	ON	ON	ON	
		Stored	ON	ON	ON	
		IP	ON	ON	ON	
	W-MCR	Result	ON	ON	ON	
		Stored	ON	ON	ON	
		IP	ON	ON	ON	
	W-LCR	Result	ON	ON	ON	
		Stored	ON	ON	ON	
		IP	ON	ON	ON	
	W-SCC	Result	ON	ON	ON	
		Stored	ON	ON	ON	
		IP	ON	ON	ON	
	W-MCC	Result	ON	ON	ON	
		Stored	ON	ON	ON	
		IP	ON	ON	ON	
	W-LCC	Result	ON	ON	ON	
		Stored	ON	ON	ON	
		IP	ON	ON	ON	
	RDW-SD	Result	ON	ON	ON	
		Stored	ON	ON	ON	
		IP	ON	ON	ON	
	RDW-CV	Result	ON	ON	ON	
		Stored	ON	ON	ON	
		IP	ON	ON	ON	
PDW	Result	ON	ON	ON		
	Stored	ON	ON	ON		
	IP	ON	ON	ON		
MPV	Result	ON	ON	ON		
	Stored	ON	ON	ON		
	IP	ON	ON	ON		
P-LCR	Result	ON	ON	ON		
	Stored	ON	ON	ON		
	IP	ON	ON	ON		
PCT	Result	ON	ON	ON		
	Stored	ON	ON	ON		
	IP	ON	ON	ON		

Item Name		For Overseas (120V) * Settings for North America	For China XP100(220V)	For China XP300(220V)	Remarks	Initialize	
SNCS (For the UK) A	For the UK	SNCS	UnUsed(0)	UnUsed(0)	UnUsed(0)		SNCS Settings
		Auto Send	Disable(0)	Disable(0)	Disable(0)	Disable/QC Data/Mainte.report/A I I	
		File Send(QC)	Disable(0)	Disable(0)	Disable(0)	Disable/Enable	
		File Send(other)	Disable(0)	Disable(0)	Disable(0)	Disable/Image/Mainte.report/A I I	
		S. Call	Disable(0)	Disable(0)	Disable(0)	Disable/Enable	
	Network Settings (Basic Information)	DHCP	Not Used(0)	Not Used(0)	Not Used(0)		
		IP Address	192.168.0.1	192.168.0.1	192.168.0.1		
		GW Address	0.0.0.0	0.0.0.0	0.0.0.0		
		Subnet Mask	255.255.255.0	255.255.255.0	255.255.255.0		
		Primary DNS	0.0.0.0	0.0.0.0	0.0.0.0		
		Secondary DNS	0.0.0.0	0.0.0.0	0.0.0.0		
		DialUp Timer	30	30	30		
		TimeZone	GMT+09:00	GMT+09:00	GMT+09:00		
		Serial No	00000	00000	00000		
		My Mail Address	sysmex00001@sncs.sysmex.co.jp	sysmex00001@sncs.sysmex.co.jp	sysmex00001@sncs.sysmex.co.jp		
		RMTSETUP	Not Used(0)	Not Used(0)	Not Used(0)		
	Network Settings (QC Data)	Server Name	sncs.sysmex.co.jp	sncs.sysmex.co.jp	sncs.sysmex.co.jp		
		Server Name Port	25	25	25		
	Authentication	Disable(0)	Disable(0)	Disable(0)			
	Auth Server Name	sncs.sysmex.co.jp	sncs.sysmex.co.jp	sncs.sysmex.co.jp			
	Auth Server Port	110	110	110			

A 313C031

Item Name		For Overseas (120V) * Settings for North America	For China XP100(220V)	For China XP300(220V)	Remarks	Initialize
SNCS (For the UK) A	Auth User Name	None	None	None	No setting	SNCS Settings
	Auth Password	None	None	None	No setting	
	To Mail Address	datareceiver@olqc.sysmex.co.jp	datareceiver@olqc.sysmex.co.jp	datareceiver@olqc.sysmex.co.jp		
	Subject	QC DATA	QC DATA	QC DATA		
	Network Settings (Maintenance Data) Server Name	sncs.sysmex.co.jp	sncs.sysmex.co.jp	sncs.sysmex.co.jp		
	Server Name Port	25	25	25		
	Authentication	Disable(0)	Disable(0)	Disable(0)		
	Auth Server Name	sncs.sysmex.co.jp	sncs.sysmex.co.jp	sncs.sysmex.co.jp		
	Auth Server Port	110	110	110		
	Auth User Name	None	None	None	No setting	
	Auth Password	None	None	None	No setting	
	To Mail Address	sysmex-log@sncs.sysmex.co.jp	sysmex-log@sncs.sysmex.co.jp	sysmex-log@sncs.sysmex.co.jp		
	Network Settings (Screen Image) Server Name	sncs.sysmex.co.jp	sncs.sysmex.co.jp	sncs.sysmex.co.jp		
	Server Name Port	25	25	25		
	Authentication	Disable(0)	Disable(0)	Disable(0)		
	Auth Server Name	sncs.sysmex.co.jp	sncs.sysmex.co.jp	sncs.sysmex.co.jp		
	Auth Server Port	110	110	110		
	Auth User Name	None	None	None	No setting	
	Auth Password	None	None	None	No setting	
	To Mail Address	sysmex-tsc01@sncs.sysmex.co.jp	sysmex-tsc01@sncs.sysmex.co.jp	sysmex-tsc01@sncs.sysmex.co.jp		
Special Settings	R.Barcode	Used	Used	Used		-
	Machine	XP300	XP100	XP300	Setting of whether the instrument type is XP100 or XP300. XP300 ... Type1(1) XP100 ... Type2(0)	-
	PD mode	20param * For output of PCT, etc, select on each setting.	20param	20param		-

A 313C031

CHAPTER 6 ERROR MESSAGES

6.1. Overview.....	1
6.1.1 Error Dialog.....	1
6.1.2 Help Button	1
6.1.3 Action Message Screen.....	1
6.1.4 Error List Screen	1
6.1.5 Error Code	1
6.1.6 Error History.....	3
6.1.7 Error Type	3
6.2 Sensor Location.....	4
6.3 Pressure/Vacuum	5
6.3.1 -0.0333MPa Error	5
6.3.2 0.05MPa Error.....	6
6.3.3 Pressure/Vac Error.....	7
6.4 Chamber.....	8
6.4.1 Waste not drained	8
6.4.2 Replace CELLPACK	8
6.4.3 Replace S.LYSER.....	9
6.4.4 CELLPACK expired.....	9
6.4.5 S.LYSER expired	10
6.5 Printers	11
6.5.1 IP Buffer Full	11
6.5.2 IP Cover open	11
6.5.3 No Printer Paper	11
6.6 Motor	12
6.6.1 Rinse motor error	12
6.6.2 Rinse MC error.....	12
6.7 Temperature	13
6.7.1 Room Temp(H).....	13
6.7.2 Room Temp(L)	13
6.8 Analysis	14
6.8.1 WBC Noise Error	14
6.8.2 RBC Noise Error	14
6.8.3 PLT Noise Error	14
6.8.4 Blank Error	14
6.8.5 HGB Error	15
6.8.6 RBC Smp'g Error	15
6.8.7 WBC Smp'g Error.....	16
6.8.8 PLT Smp'g Error.....	16
6.8.9 WBC Analysis Err	16
6.8.10 RBC Analysis Err	17

6.9 Memory.....	18
6.9.1 RAM Error	18
6.9.2 ROM Error	18
6.9.3 Settings Error	18
6.9.4 Stored Error.....	18
6.9.5 QC Data Error	19
6.10 Host Output (Option)	20
6.10.1 LAN Buffer Full.....	20
6.10.2 HC Buffer Full	20
6.10.3 HC Off-line	20
6.10.4 HC ACK Timeout.....	20
6.10.5 HC NAK Retry.....	21
6.10.6 LAN no Response.....	21
6.10.7 GP Buffer Full	21
6.10.8 GP Printout Error	22
6.10.9 GP Paper Empty	22
6.11 Detector Unit.....	23
6.11.1 Aperture Clog (RBC)	23
6.11.2 Aperture Clog (WBC)	23
6.12 Maintenance	25
6.12.1 Clean Waste Chamber.....	25
6.12.2 Clean the SRV	25
6.12.3 Clean Transducer.....	25
6.12.4 Execute shutdown.....	26
6.13 SNCS.....	27
6.13.1 SNCS Comm. Error	27
6.13.2 SNCS Status Error	27
6.13.3 SNCS Connection.....	28
6.13.4 SNCS Setting Error.....	28
6.13.5 Service Call.....	29
6.14 Others.....	30
6.14.1 QC(X-bar) Error	30
6.14.2 QC(L-J) Error	30
6.14.3 Calibration Error	30
6.15 Pressure value convert table	31

CHAPTER 6 ERROR MESSAGES

6.1. Overview

6.1.1 Error Dialog

When a trouble occurs, the warning alarm sounds and an error dialog is displayed on the screen. In the screen, [HELP] button is displayed. However, if a trouble occurs during sequence, error dialog is displayed at the same time as the error occurrence, and [HELP] button cannot be pressed until the completion of the sequence. The alarm is beeping sound, and the sound stops when [CLOSE] button is pressed on error dialog.

6.1.2 Help Button

When an error occurs, [HELP] button blinks every 0.5 second. By pressing [HELP] button at that time, action message screen (when only one error occurs) or error list screen (when several errors occur) is displayed.

6.1.3 Action Message Screen

This screen shows error details and countermeasure. When several errors are occurring at the same time, action message for the error with the highest priority is displayed.

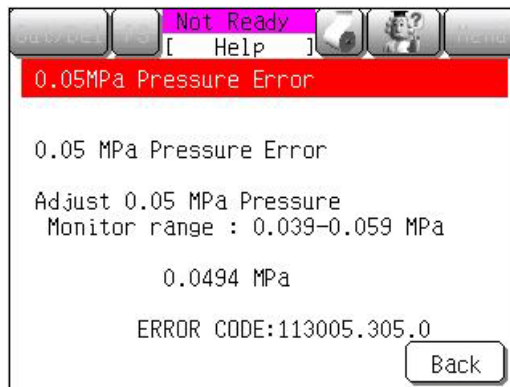

6.1.4 Error List Screen

This screen shows a list of errors (8 errors at maximum) that are currently occurring in the order of priority. Pressing [Detail] button shows an action message for the error with the highest priority. By pressing [Back] button, the screen goes back to the previous screen.

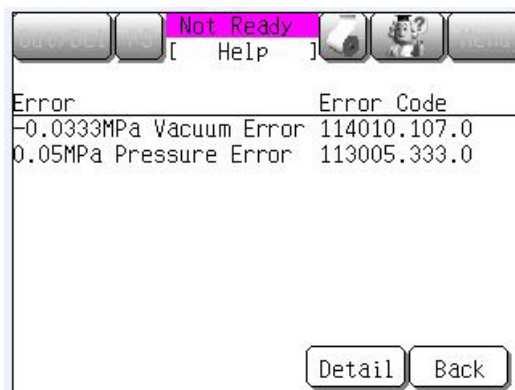

6.1.5 Error Code

Error codes are displayed in the error list screen and action message screen. Error code is made up by values of 6 digits, 4 digits, and 3 digits. (AAAAAA + XXXX + ZZZZ) The values with 6 digits (AAAAAA) are error code for error message, and exist one error code (AAAAAA) for one error message. The rest of the two values show condition when the error occurs. Therefore, the values (XXXX or ZZZZ) can change even for the same error message depending on the condition.

Error code list

Error Description	Error Code (AAAAAA)	Sub Code 1 (XXXX)	Sub Code 2 (ZZZZ)	Remarks
-0.0333MPa Error	114010	Vacuum value	Sequence No.	
0.05MPa Error	113005	Pressure value	Sequence No.	
Pressure/Vac Error	119010	Pressure value	Sequence No.	
Waste not drained	141000	0	0	
Replace CELLPACK	131000	0	1	In case error description (a)
		0	2	In case error description (b)
Replace S.LYSER	133220	0	1	In case error description (a)
		0	2	In case error description (b)
WBC Noise Error	412010	0	0	
RBC Noise Error	412020	0	0	
PLT Noise Error	412030	0	0	
Blank Error	411010	0	0	
Aperture Clog (RBC)	311240	Count time or clog	0	
Aperture Clog (WBC)	311140	Count time or clog	0	
HGB Error	415000	HGB background data value	HGB sample data value	
RBC Smp'g Error	413020	0	0	
WBC Smp'g Error	413010	0	0	
PLT Smp'g Error	413030	0	0	
Rinse MC error	452030	0	0	
WBC Analysis Err	416100	0	0	
RBC Analysis Err	417080	Conductivity	0	
Room Temp(H)	122510	Temperature	0	
Room Temp(L)	122515	Temperature	0	
Rinse motor error	243000	0	0	
Clean Waste Chamber	471030	0	0	
Clean the SRV	471010	0	0	
Clean Transducer	471100	0	0	
RAM Error	431010	0	0	
ROM Error	431020	0	0	
Settings Error	431030	File No.	0	
Stored Error	432010	File No.	0	
QC Data Error	463000	File No.	0	
IP Buffer Full	448010	0	0	
LAN Buffer Full	486030	0	0	
IP Cover open	421502	0	0	
No Printer Paper	448020	0	0	
HC Buffer Full	441010	0	0	
HC Off-line	441020	0	0	
HC ACK Timeout	441030	0	0	
HC NAK Retry	442020	0	0	
LAN no Response	486000	0	0	
GP Printout Error	443010	0	0	
GP Paper Empty	443020	0	0	
Calibration Error	466010	0	0	
Execute shutdown	471040	0	0	

SNCS Comm. Error	487010	Error details code	0
SNCS Status Error	487011	Error details code	0
SNCS Connection	487012	Error details code	0
SNCS Setting Error	487013	Error details code	0
Service Call	900000	0	0
GP Buffer Full	443040	0	0
CELLPACK expired	472020	0	0
Replace S.LYSER	472034	0	0
QC(X-bar) Error	461150	0	0
QC(L-J) Error	461160	0	0

AAAAAA.XXXX.ZZZZ

A: Error Code (Phenomenon)

X: Value 1

Z: Value 2

*XXXX and ZZZZ have different meanings depending on the error code.

6.1.6 Error History

Error history can be printed by selecting [Print error history] from [Service] menu.

6.1.7 Error Type

Errors can be classified into the following types.

Type	Condition	How to recover	Remarks
1	Unable to perform operation	Turn off main power	Unable to perform menu operation (system abnormality)
2	Unable to perform analysis	Perform error recovery process	Able to perform menu operation (pressure error, etc.)
3	Able to perform analysis	Close error dialog	Errors specific to sample, or errors with no influence to the next analysis, such as abnormality of peripheral device.

6.2 Sensor Location

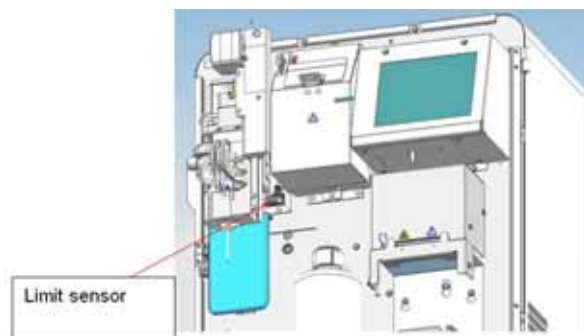
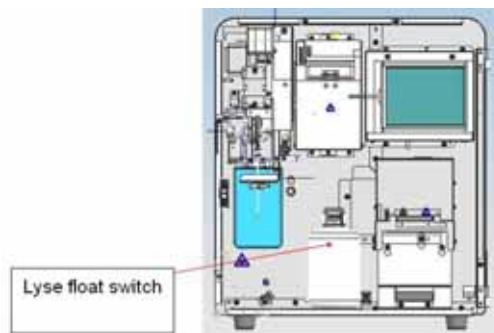
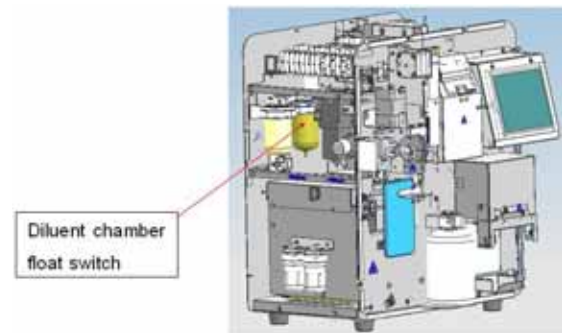
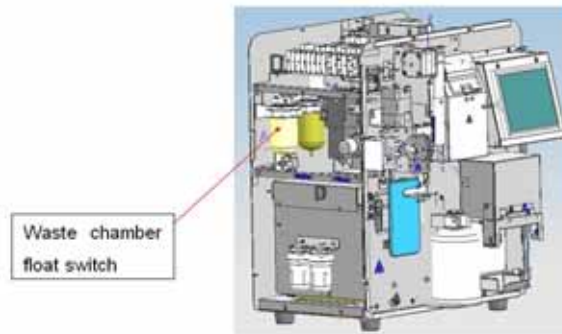

6.3 Pressure/Vacuum

6.3.1 -0.0333MPa Error

Description:-0.0333MPa vacuum is outside the operating range.

Function:The system secures the drain operation from the waste chamber and operation of diaphragm pumps.

Check method:The instrument system checks if the vacuum is within the following range by converting the voltage of the -0.0333MPa vacuum sensor.

***Sub code 1: Vacuum value**

***Sub code 2: Sequence No.**

-In Ready mode: System monitors every 200ms. The condition is treated as error when vacuum deviates the following acceptable range for 1.2 seconds continuously.

-0.0307 and above ~ -0.0360 and below [MPa]

-230 and above ~ - 270 and below [mmg](Reference) (Refer to 6.15 pressure value convert table)

(Used for sub code 1)

-During analysis: System monitors in the following timing. The condition is treated as error when vacuum deviates the acceptable range described below.

Whole Blood Mode

At the start of sequence 1 (At 0.5 sec. before mix chamber and W/R detection chamber dispense)

At 0.4 sec. after the start of sequence 2 (When dispensing HGB background convert sample)

At the start of sequence 4 (When charging RBC)

At 0.9 sec. after the start of sequence 4 (When mix chamber and W/R detection chamber dispense)

At 1.6 sec. after the start of sequence 7 (When aspirating HGB sample convert sample)

At the start of sequence 9 (At 0.5 sec. before W/R detect chamber dispenses)

At 6.4 sec. after the start of sequence 9 (When aspirating HGB flow cell rinse solution)

At 8.6 sec after the start of sequence 9 (When W/R detection chamber dispenses.)

At 0.1 sec after the stat of sequence 10 (When aspirating HGB flow cell rinse solution)

(Used for sub code 2)

Pre-Diluted Mode

At the start of sequence 1 (At 0.5 sec. before mix chamber and W/R detection chamber dispense)

At 0.4 sec. after the start of sequence 2 (When aspirating HGB background convert sample)

At 1.4 sec. after the start of sequence 3 (When mix chamber and W/R detection chamber dispense)

At 1.6 sec. after the start of sequence 7 (When aspirating HGB sample convert sample)

At the start of sequence 9 (At 0.5 sec. before W/R detection chamber dispense)

At 8.9 sec. after the start of sequence 9 (When aspirating HGB flow cell rinse solution)

At 11.6 sec. after the start of sequence 9 (When W/R detection chamber dispenses)

At 0.1 sec. after the start of sequence 10 (When aspirating HGB flow cell rinse solution)

(Used for sub code 2)

-0.0133 and above ~ -0.0360 and below [MPa]

-100 and above ~ -270 and below [mmHg](Reference)(Refer to 6.15 pressure value convert table)
(Used for sub code 1)

Action: If vacuum returns to the normal range after pressing [HELP] button, the vacuum is assumed to have recovered and the system enters the ready mode.

6.3.2 0.05MPa Error

Description:0.05MPa pressure is outside the operating range.

Function:The system secures the drain operation from diaphragm pumps and the mixing operation in the transducer chambers and Hgb flow cell.

Check method:The instrument system checks if the pressure is within the following range by converting the voltage of the 0.05MPa pressure sensor.

***Sub code 1: Pressure value**

***Sub code 2: Sequence No.**

-In Ready mode: System monitors every 200ms. The condition is treated as error when pressure deviates the following acceptable range for 1.2 seconds continuously.

From 0.039 and above - 0.059 and below[MPa]

From 0.40 and above - 0.60 and below[kg/cm²](Reference)(Refer to 6.15 pressure value convert table)

(Used for sub code 1)

-During analysis: System monitors in the following timing. The condition is treated as error when pressure deviates the acceptable range described below.

Whole Blood Mode

At 3.0 sec. after the start of sequence 1(WBC DP dispense-HGB background convert sample dispense)

At the start of sequence 3 (RBC DP dispense-1st dilution)

At 3.0 sec. after the start of sequence 4 (Lyse Reagent DP/WBC DP dispense)

At the start of sequence 6 (RBC DP dispense-2nd dilution)

(Used for sub code 2)

Pre-Diluted (PD) Mode

At 3.0 sec. after the start of sequence 1(WBC DP dispense-HGB background convert sample dispense)

At the start of sequence 3 (RBC DP dispense-WB mode rinse)

At the start of sequence 5 (RBC DP dispense, Lyse Reagent DP/WBC DP dispense)

(Used for sub code 2)

0.029 and above - 0.059 and below [MPa]

0.30 and above - 0.60 and below [kg/cm²] (Reference)(Refer to 6.15 pressure value convert table)

(Used for sub code 1)

Action: If pressure returns to the normal range after pressing [HELP] button, the pressure is assumed to have recovered and the system enters the ready mode.

6.3.3 Pressure/Vac Error

Description: Pressure is outside the operating range.

Function: The system secures the operation of SV, valve, and DP etc.

Check method: The instrument system checks if the pressure is within the following range by converting the voltage of the 0.5kg/cm²(0.05MPa) pressure sensor.

***Sub code 1: Pressure value**

***Sub code 2: Sequence No.**

System monitors every 200ms. The condition is treated as error when pressure deviates the following acceptable range for 1.2 seconds continuously.

0.0200 and above [MPa]

(Used for sub code 1)

- Action:
- (1) The system immediately stops the currently running sequence.
 - (2) All the solenoid valves and pneumatic unit are turned OFF.
 - (3) Subsequent operation cannot be continued and waited in power OFF condition.

6.4 Chamber

6.4.1 Waste not drained

Description: The waste chamber fails to drain.

Function: The system secures drainage of waste fluid from the waste chamber and acceptance of new waste.

Check method: System checks that the float switch in the waste chamber (sensor F SW1) is ON (the float is in the lower limit).

- In the Ready mode: System monitors every 100msec.
- When the Main Unit is ON: System monitors at SV1 OFF (completion of drain)

Action: At the completion of waste chamber draining sequence, the system enters the ready mode if the abnormality is recovered.

6.4.2 Replace CELLPACK

Description: (a) Diluent (CELLPACK) cannot be aspirated into the reagent chamber within the specified time, or air bubbles enter, resulting in the diluent chamber float going up and down.
(b) After the replacement of CELLPACK, the available cycles have reached 500 (for 10L) or 1000 (for 20L).

Function: (a) The system secures reagent volume required for analysis. Or, the system detects that air bubbles enter the diluent chamber.
(b) This error is used as a function to monitor reagent.

Check method: Monitoring conditions: (In case of (a))

- (1) System assumes to be an error when replenishing time is longer than 7 seconds.
- (2) System assumes the entering of air bubbles when the float switch (Sensor F SW2) turns ON (lower) between 0.2 seconds and 0.4 seconds after the float switch turns OFF (upper).
- (3) System assumes to be an error when the replenishing time is longer than 15.0 seconds.
- (4) System assumes to be an error when the replenishing time is longer than 14.5 seconds.
- (5) System assumes to be an error when the replenishing time is longer than 30.0 seconds.

During normal analysis

The above (1) and (2) monitoring are performed.

During the initialization, or in the reagent replenish sequence

The above (3) monitoring is performed.

During Factory Rinsing, or Shipping sequence

The above (4) and (5) monitoring are performed.

During Setting sequence

The above (1) and (5) monitoring are performed.

On the other sequences

The above (1) monitoring is performed.

In the Ready mode

Monitoring is not performed.

Monitoring conditions: (In case of (b))

After the completion of analysis, system checks analysis count is 500 or 1000 and below.

Action: (1) During operation

The system performs diluent replenishing sequence (auto rinse, background check).

(2) In case of the following operations are performed

-shutdown

-auto rinse

-waste chamber rinse

This system performs diluent replenishing sequence. Then, the system enters Ready when no abnormality is found.

6.4.3 Replace S.LYSER

Description:(a)The available cycles reaches the specified count after the float switch for monitoring the lyse reagent turns ON.

(b) After the replacement of lyse, the available cycles has reached to 800.

Function:(a)The system secures lyse reagent volume remained for analysis.

(b) This error is used as a function to monitor reagent.

Check method:Monitoring conditions: (In case of (a))

System checks that the cycle is 95 and below after the float switch for monitoring the lyse reagent (F SW7) turns ON (when DP for lyse dispenses).

Monitoring conditions: (In case of (b))

After the completion of analysis, system checks analysis count is 800 and below

Action: (1) During operation

The system performs lyse replenishing sequence (auto rinse, background check).

(2) In case of the following operations are performed

-shutdown

-auto rinse

-waste chamber rinse

This system performs lyse replenishing sequence. Then, the system enters Ready when no abnormality is found.

6.4.4 CELLPACK expired

Description:This error shows that reagent expiry date has expired.

Function:System secures data accuracy.

Check method:System compares expiry date and current date when the start button is pressed. (Action message is displayed after the completion of rinsing rinse cup.)

Action: (1) During operation
The system performs diluent replenishing sequence (auto rinse, background check).

(2) In case of remarks
This system performs diluent replenishing sequence. Then, after the completion of the sequence, the system enters Ready when no abnormality is found, by returning to the first step of the sequence.

6.4.5 S.LYSER expired

Description: This error shows that reagent expiry date has expired.

Function: System secures data accuracy.

Check method: System compares expiry date and current date when the start button is pressed. (Action message is displayed after the completion of rinsing rinse cup.)

Action: (1) During operation
The system performs lyse replenishing sequence (auto rinse, background check).

(2) In case of remarks
This system performs lyse replenishing sequence. Then, after the completion of the sequence, the system enters Ready when no abnormality is found, by returning to the first step of the sequence.

6.5 Printers

6.5.1 IP Buffer Full

Description: This error shows that output data to IP has overflowed.

Function: System secures IP printing operation.

Check method: System treats the condition as error when output data has overflowed during initialization or output request.

Action: The system recovers by pressing [Return] button. However, if there is data already under outputting, the data output process continues.

6.5.2 IP Cover open

Description: This error shows IP cover remains open.

Function: System secures IP printing operation.

Check method: System treats the condition as error if printing operation starts when IP cover remains half-opened during initialization, at the start of printing, or during printing operation.

Reference:

If printing operation starts when IP cover remains completely open, "No Printing Paper" is displayed.

Action: (1) By pressing [Retry] button in action message screen, the system recovers, and printing operation restarts.
(2) To delete samples under printing operation, or waiting to be printed, click [Cancel] button in action message screen. Then, the system recovers and returns to the previous screen.

6.5.3 No Printer Paper

Description: This error shows IP printing paper has run out.

Function: System secures IP printing operation.

Check method: System treats the condition as error when IP printer sensor detects that printing paper has run out during initialization or printing operation.

Action: (1) By pressing [Retry] button in action message screen, the system recovers, and data under printing status restarts.
(2) By pressing [Cancel] button in action message screen, data under printing process, or waiting to be printed, will be deleted. Then, the system recovers and returns to the previous screen.

6.6 Motor

6.6.1 Rinse motor error

Description: The rinse cup is at the lower position when the main power turns ON.
The rinse cup operation is abnormal.

Function: System prevents blood and rinsing solution from splashing when cleaning the whole blood aspiration pipette. System also eliminates carryover from the previous sample. In addition, system secures that the pipette does not get bent.

Check method: • When the main power is turned ON, system confirms that the rinse cup is not at the lower position.

System monitors whether the rinse cup reaches the lower limit at the timing described in the timing chart by confirming that the photo interrupter at the lower limit is ON.

- Action:
- (1) The system stops the currently running sequence.
 - (2) All the solenoid valves and pneumatic unit are turned OFF.
 - (3) Subsequent operation cannot be continued and waited in power OFF condition.

6.6.2 Rinse MC error

Description: The controller for operating rinse cup is abnormal.

Function: System prevents blood and rinsing solution from splashing when cleaning the whole blood aspiration pipette. System also eliminates carryover from the previous sample. In addition, system secures that the pipette does not get bent.

Check method: System treats the condition as error if a status is received when application performs read/write to motor controller.

- Action:
- (1) The system stops the currently running sequence.
 - (2) All the solenoid valves and pneumatic unit are turned OFF.
 - (3) Subsequent operation cannot be continued and waited in power OFF condition.

6.7 Temperature

6.7.1 Room Temp(H)

Description:Room temperature is out of the acceptable range.

Function:System secures the HCT temperature compensation and PLT S/N (Signal to noiseratio), and avoids blood clotting on the cold agglutinin disease samples. System also secures hemolyzing in WBC samples.

Check method:System monitors A/D converted value of the thermistor installed in the instrument, and checks the temperature is within the following range. (monitors 1.5 sec. before starting the calculation)

From 10.0 to 40.0

***Sub code 1: Temperature**

Action: After the analysis sequence for aspirated sample has completed, built-in printer prints the data (the related data is printed normally). Then, system enters the ready mode.

6.7.2 Room Temp(L)

Description:Room temperature is out of the acceptable range.

Function:System secures the HCT temperature compensation and PLT S/N (Signal to noiseratio), and avoids blood clotting on the cold agglutinin disease samples. System also secures hemolyzing in WBC samples

Check method:System monitors A/D converted value of the thermistor installed in the instrument, and checks the temperature is within the following range. (monitors 1.5 sec. before starting the calculation)

From 10.0 to 40.0

***Sub code 1: Temperature**

Action: After the analysis sequence for aspirated sample has completed, built-in printer prints the data (the related data is printed normally). Then, system enters the ready mode.

6.8 Analysis

6.8.1 WBC Noise Error

Description:Overrun of A/D converter occurs. Overflow of counter occurs. Clearing the counter is not correctly performed.

Function:System secures the counting procedure.
System secures importing correct data.

Check method:Judged by status register's contents in gate alley after completing data import.

Action: After all the analysis sequence for the aspirated samples are completed, built-in printer prints the data. Then, system enters the ready mode.

6.8.2 RBC Noise Error

Description:Overrun of A/D converter occurs. Overflow of counter occurs. Clearing the counter is not correctly performed.

Function:System secures the counting procedure.
System secures importing correct data.

Check method:Judged by status register's contents in gate alley after completing data import.

Action: After all the analysis sequence for the aspirated samples are completed, built-in printer prints the data. Then, system enters the ready mode.

6.8.3 PLT Noise Error

Description:Overrun of A/D converter occurs. Overflow of counter occurs. Clearing the counter is not correctly performed.

Function:System secures the counting procedure.
System secures importing correct data.

Check method:Judged by status register's contents in gate alley after completing data import

Action: After all the analysis sequence for the aspirated samples are completed, built-in printer prints the data. Then, system enters the ready mode.

6.8.4 Blank Error

Description:Background value of any parameter exceeds the preset limit, and the gap of count results will be falsely increased.

Function: System secures that the background value for all parameters is lower than the preset limit so as not to influence the analysis data.

Check method: System checks that the background value is lower than the following limits.

WBC: 3 [$\times 10^2/\mu\text{L}$]

RBC: 2 [$\times 10^4/\mu\text{L}$]

HGB: 0.1 [g/dL]

PLT: 1.0 [$\times 10^4/\mu\text{L}$]

Action: System runs auto rinsing.

6.8.5 HGB Error

Description: A/D converted HGB background value or HGB sample value exceeds the preset limit.

Function: System ensures that the HGB value is analyzed without any problem.

Check method: HGB error occurs when the A/D converted HGB background value or HGB sample value meets either of the following conditions.

***sub code 1: HGB background convert value**

***sub code 2: HGB sample convert value**

Background < 50

Background > 10000

(Sample - Background) < -50

(Sample - Background) > 3600

Action: After the analysis sequence for aspirated sample has completed, the data is masked.

6.8.6 RBC Smp'g Error

Description: During RBC counting, system detects the abnormal uniformity of the counted cell pulses that is beyond the preset limit.

Function: System monitors uniform cell pulses of RBC sample to monitor clog in the RBC transducer aperture.

Check method: System calculates sampling values every 0.5 seconds during RBC counting. When the maximum value, minimum value, and sum of sampling values satisfy the following equations, system judges that a noise is generated.

$(\text{Maximum value} - \text{Minimum value} - 1250) \times 100 / \text{Sum of sampling values} > 2.0$ [%]

(Apply the equation above to sampling data 3-19.)

Action: (1) After the analysis sequence for aspirated sample has completed, the data is masked.
(2) The count starting level for the sampling value is 25 fL.

6.8.7 WBC Smp'g Error

Description: During WBC counting, system detects the abnormal uniformity of the counted cell pulses that is beyond the preset limit.

Function: System monitors uniform cell pulses of WBC sample to monitor clog in the WBC transducer aperture.

Check method: System calculates sampling values every 0.5 seconds during WBC counting. When the maximum value, minimum value, and sum of sampling values satisfy the following equations, system judges that a noise is generated.

$$\text{Maximum value} - \text{Minimum value} - 200 \times 100 / \text{Sum of sampling values} > 2.0 [\%]$$

(Apply the equation above to sampling data 3-19.)

Action: (1) After the analysis sequence for aspirated sample has completed, the data is masked.
(2) The count starting level for the sampling value is 30 fL.

6.8.8 PLT Smp'g Error

Description: During PLT counting, system detects the abnormal uniformity of the counted cell pulses that is beyond the preset limit.

Function: System monitors uniform cell pulses of PLT sample to monitor clog in the PLT transducer aperture.

Check method: System calculates sampling values every 0.5 seconds during PLT counting. When the maximum value, minimum value, and sum of sampling values satisfy the following equations, system judges that a noise is generated.

$$\text{Maximum value} - \text{Minimum value} - 100 \times 100 / \text{Sum of sampling values} > 2.0 [\%]$$

(Apply the equation above to sampling data 3-17.)

Action: (1) After the analysis sequence for aspirated sample has completed, the data is masked.
(2) The count starting level for the sampling value is 2fL.

6.8.9 WBC Analysis Err

Description: Tri-modal particle size distribution cannot be correctly divided.

Function: System monitors the counterfeit lyse reagent.

Check method: System verifies that the number of cases when the tri-modal particle size cannot be correctly counted is less than 10 consecutively.

Action: The message [Analysis Error] is displayed and the alarm sounds. The message remains displayed until the error is recovered or the power is turned OFF. There are two types of the data display method, and settings can be changed by DIP SW.
(CPU board DIP SW S1 bit 6. ON: Level 2, OFF: Level 1)

(1) Level 1: O

(2) Level 2: The tri-modal data not analyzed automatically are displayed as "---.". * (low reliability mark) is attached to the obtained bi-modal data.

6.8.10 RBC Analysis Err

Description:Electrical conductivity gets out of the control limit.

Function:System monitors the counterfeit diluent.

Check method:System verifies that the electrical conductivity is within the range of 80 C 125.

***Sub code 1: Electrical conductivity**

Action: The message [Analysis Error] is displayed and the alarm sounds. The message remains displayed until the error is recovered or the power is turned OFF. There are two types of the data display method, and settings can be changed by DIP SW.
(CPU board DIP SW S1 bit 6. ON: Level 2, OFF: Level 1)

(1) Level 1: HCT and MCV data are displayed as "---.-".

(2) Level 2: * (low reliability mark) is attached to the HCT and MCV data.

6.9 Memory

6.9.1 RAM Error

Description: The main CPU detects an error to access the RAM (Random Access Memory).

Function: System ensures that the main CPU accesses the RAM without any problem.

Check method: System writes test data to a certain address at power-on, and checks whether the same data is read later. System repeats the same check procedure sequentially for every RAM address.

Action: System stops the operation immediately. The error is reset by turning OFF the power switch.

6.9.2 ROM Error

Description: The main CPU detects an error to read data from ROM (Read Only Memory).

Function: System ensures that the main CPU reads the program from the ROM correctly.

Check method: System performs a ROM checksum (reads data from the entire area, calculates the total, and finds the 8 low order bits). Then, system checks that the value matches the checksum value stored in the ROM.

Action: System stops the operation immediately. The error is reset by turning OFF the power switch.

6.9.3 Settings Error

Description: This error shows there is an abnormality in BBU-RAM.

Function: System ensures that the settings are correctly displayed.

Check method: System performs checksum for dual file when the main power is turned ON.

Action: (1) System tries to restore when [Restore] button is pressed in action message screen.

Stored sample file: Delete any records that checksum is inconsistent

Settings file: Perform mirroring to the correct file that is duplicated.

Then, system restarts after the file system consistency is confirmed.

If [Restore] is impossible, the file error occurred only is initialized.

(2) When [Initialize] button is pressed in action message screen, confirmation dialog is displayed. If [Execute] button is selected in the dialog, overall BBU-RAM file system is initialized.

6.9.4 Stored Error

Description: This error shows there is an abnormality in BBU-RAM.

Function: System ensures that the stored samples are correctly displayed.

Check method: System performs checksum for the maximum record number, stored record number, and each record when the main power is turned ON.

Action: (1) System tries to restore when [Restore] button is pressed in action message screen.

Stored sample file: Delete any records that checksum is inconsistent

Settings file: Perform mirroring to the correct file that is dislocated.

Then, system restarts after the file system consistency is confirmed.

If [Restore] is impossible, the file error occurred only is initialized.

(2) When [Initialize] button is pressed in action message screen, confirmation dialog is displayed. If [Execute] button is selected in the dialog, overall BBU-RAM file system is initialized.

6.9.5 QC Data Error

Description: This error shows there is an abnormality in BBU-RAM.

Function: System ensures that the QC data is correctly displayed.

Check method: System performs checksum for the maximum record number, stored record number, and each record number when the main power is turned ON

Action: (1) System tries to restore when [Restore] button is pressed in action message screen.

Stored sample file: Delete any records that checksum is inconsistent

Settings file: Perform mirroring to the correct file that is duplicated.

Then, system restarts after the file system consistency is confirmed.

If [Restore] is impossible, the file error occurred only is initialized.

(2) When [Initialize] button is pressed in action message screen, confirmation dialog is displayed. If [Execute] button is selected in the dialog, overall BBU-RAM file system is initialized.

6.10 Host Output (Option)

6.10.1 LAN Buffer Full

Description: This error shows output data to LAN has overflowed.

Function: System ensures LAN output.

Check method: System treats the condition as error if output data has overflowed under the output request process.

Action: The error recovers when [Return] button is selected in action message screen. However, if there is data being output, the operation continues. The rest of the data will be discarded.

6.10.2 HC Buffer Full

Description: This error shows the communication with HC has failed.

Function: System ensures to communicate with HC.

Check method: System treats the condition as error if output data has overflowed under the output request process.

Action: The error recovers when [Return] button is selected in action message screen. However, if there is data being output, the operation continues. The rest of the data will be discarded.

6.10.3 HC Off-line

Description: This error shows the communication with HC has failed.

Function: System ensures to communicate with HC.

Check method: System treats the condition as error if either of the following status are met when communicating with host computer.

1. Flaming error, parity error and overrun error are detected.
2. DSR is not active.
3. Texts other than ACK/NAK are sent from host computer after data is sent.

Action: (1) The error recovers and performs retry when [Retry] button is selected in action message screen.
(2) The error recovers when [Cancel] button is selected, and all output data in buffer is erased.

6.10.4 HC ACK Timeout

Description: This error shows the communication with HC has failed.

Function: System ensures to communicate with HC.

Check method: System treats the condition as error if either of the following status are met when communicating with host computer.

1. CTS does not change to active within 5 sec. after sending data.
2. ACK/NAK reply from host computer is not sent within 15 sec. after sending data.

Action: (1) The error recovers and performs retry when [Retry] button is selected in action message screen.
(2) The error recovers when [Cancel] button is selected, and all output data in buffer is erased.

6.10.5 HC NAK Retry

Description: This error shows the communication with HC has failed.

Function: System ensures to communicate with HC.

Check method: System treats the condition as error when text other than AKC is sent at 4th time after sending data.

Action: (1) The error recovers and performs retry when [Retry] button is selected in action message screen.
(2) The error recovers when [Cancel] button is selected, and all output data in buffer is erased.

6.10.6 LAN no Response

Description: This error shows the communication with LAN has failed.

Function: System secures to communicate with LAN.

Check method: System treats the condition as error when TCP connection has failed.

<Monitoring Timing>

When output to host computer is made in case LAN is set to output location.

Action: (1) The error recovers and performs retry when [Retry] button is selected in action message screen. New samples can be analyzed by releasing error by recovery action.
(2) Sending data is canceled when [Cancel] button is selected. Then, error recovers, and new analysis becomes available.

6.10.7 GP Buffer Full

Description: This error shows the output data to GP has overflowed.

Function: System secures GP printing.

Check method: System treats the condition as error if output data has overflowed under initialization or output request process.

Action: The error recovers when [Return] button is selected in action message screen. However, if there is data being output, the operation continues.

6.10.8 GP Printout Error

Description: This error shows GP is turned OFF, device error, or there is abnormality in a cable to GP.

Function: System ensures printing analysis result.

Check method: System treats the condition as error if GP is turned OFF, device error, or there is abnormality in a cable to GP.

<Monitoring Timing>

At the start of printing-at the end of printing

- Action:
- (1) By pressing [Retry] button in action message screen, the system recovers, and printing operation restarts.
 - (2) To delete samples under printing operation, or waiting to be printed, click [Cancel] button in action message screen. Then, the system recovers and returns to the previous screen.

6.10.9 GP Paper Empty

Description: Graphic printer is out of paper.

Function: The system secures printing of measurement results.

Check method: System checks the paper-empty bit of the graphic printer throughout the printing process.

<Monitoring Timing>

At the start of printing-at the end of printing

- Action:
- (1) By pressing [Retry] button in action message screen, the system recovers, and printing operation restarts.
 - (2) To delete samples under printing operation, or waiting to be printed, click [Cancel] button in action message screen. Then, the system recovers and returns to the previous screen.

6.11 Detector Unit

6.11.1 Aperture Clog (RBC)

Description: The RBC transducer aperture has clogging.

Function: System secures the RBC analysis.

Check method: System verifies the sampling data at the completion of the counting is within the following range after performing auto rinse. (monitored by clogging signal)

*Subcode 1: Clogging or calculated time

Monitoring by clogging signal

During Auto Rinsing : System monitors clogging rate at 0.5 seconds before completion of the background check on the auto rinse.

Clogging rate: C 120

$$C = 3.333 \times 10 \times D \times 5.05/256$$

$$-2.961 \times T_{TD}^2 \times 10^{-2}$$

$$+3.376 \times T_{TD}$$

$$-6.590 \times 10$$

C : Clogging Rate (integral value, round to decimal point)

D : A/D converted value of the clogging voltage

T_{TD}: Detector block temperature (**.*°C)

Monitoring by sampling data

Mean value of the three sampling data before the gate OFF is SE, and mean value of the sampling data 3-19 (1.0 s - 9.5 s) is SH.

SE/SH 0.5

Sampling data n: number of the sampling data between (n-1)/2 and n/2

Sampling data 3: number of the sampling data between 1.0 s and 1.5 s.

Sampling data 19: number of the sampling data between 9.0 s and 9.5 s.

Action: After all the sequences for the aspirated samples are completed, the system enters the ready mode.

6.11.2 Aperture Clog (WBC)

Description: The WBC transducer aperture has clogging.

Function: System secures the WBC analysis.

Check method: System verifies the sampling data at the completion of the counting is within the following range after performing auto rinse. (monitored by clogging signal)

*Subcode 1: Clogging or calculated time

Monitoring by clogging signal

During Auto Rinsing : System monitors clogging rate at 0.5 seconds before completion of the background check on the auto rinse.

Clogging rate: C 120

$$C = 3.333 \times 10 \times D \times 5.05/256$$

$$-2.961 \times T_{TD}^2 \times 10^{-2}$$

$$+3.376 \times T_{TD}$$

$$-6.590 \times 10$$

C : Clogging Rate (integral value, round to decimal point)

D : A/D converted value of the clogging voltage

T_{TD}: Detector block temperature (**.*°C)

Monitoring by sampling data

Mean value of the three sampling data before the gate OFF is SE, and mean value of the sampling data 3 - 19 (1.0 s - 9.5 s) is SH.

SE/SH 0.5

Sampling data n: number of the sampling data between (n-1)/2 and n/2

Sampling data 3: number of the sampling data between 1.0 s and 1.5 s.

Sampling data 19: number of the sampling data between 9.0 s and 9.5 s.

Action: After all the sequences for the aspirated samples are completed, the system enters the ready mode.

6.12 Maintenance

6.12.1 Clean Waste Chamber

Description: The main CPU detects that the cycle counter reaches the preset value. It is the time to clean the waste chamber.

Function: System alerts the operator to clean the waste chamber.

Check method: System checks the number of days since the previous cleaning time, and cycle count only at power ON. When the waste chamber cycle count reaches 1500 or passes a month, this message is displayed. The cycle count increments by 1 for every execution of analysis sequence.

- Action:
- (1) Message alert only, and the system operates as usual.
 - (2) The cycle count can be reset on the select menu.

6.12.2 Clean the SRV

Description: The main CPU detects that the cycle counter reaches the preset value. It is the time to clean the SRV.

Function: System alerts the operator to clean the SRV.

Check method: System checks the number of days since the previous cleaning time, and cycle count only at power ON. When the waste chamber cycle count reaches 4500 or passes 3 months, this message is displayed. The cycle count increments by 1 for every execution of analysis sequence.

- Action:
- (1) Message alert only, and the system operates as usual.
 - (2) The cycle count can be reset on the select menu.

6.12.3 Clean Transducer

Description: The main CPU detects that the cycle counter reaches the preset value. It is the time to clean the waste chamber.

Function: System alerts the operator to clean the transducer.

Check method: System checks the number of days since the previous cleaning time, and cycle count only at power ON. When the waste chamber cycle count reaches 1500 or passes 1 month, this message is displayed. The cycle count increments by 1 for every execution of analysis sequence.

- Action:
- (1) Message alert only, and the system operates as usual.
 - (2) The cycle count can be reset on the select menu.

6.12.4 Execute shutdown

Description: The instrument is not shut down for 24 hours.

Function: System alerts the operator to shut down the instrument.

Check method: System treats the condition as error if shutdown alert timer detects the condition that the instrument is not shut down for 24 hours.

(Depending on the shutdown alert timer settings.)

Action: None

6.13 SNCS

6.13.1 SNCS Comm. Error

Description: The following error has occurred.

sub error code (XXXXXX)	Details
411	Linking down
412	DHCP address release
421	DNS response analysis error
422	DNS response timeout error
429	DNS other errors
431	POP server detection error
432	POP server connection timeout error
433	POP server listen error
434	POP response analysis error
435	POP certification error
436	POP cut off error
437	POP server response timeout error
439	POP other errors
441	SMTP server detection error
442	SMTP server connection timeout
443	SMTP server listen error
444	SMTP response analysis error
445	SMTP cut off error
446	SMTP response timeout error
449	SMTP other errors
490	kernel program error
499	Other errors

Function: System ensures SNCS communication.

Check method: System treats the condition as error if sub error code (XXXXXX) is detected when SNCS auto sending/manual sending is being performed.

Action: [Retry] button recovers error, and performs re-sending.
[Cancel] button recovers error, and goes back to the previous screen.

6.13.2 SNCS Status Error

Description: The following error has occurred.

sub error code (XXXXXX)	Details
-------------------------	---------

101	Timeout error for system parameter settings (After power ON, timeout error for system parameter settings)
102	Timeout error for mail acceptable status after system parameter is issued
103	Timeout error for mail acceptable status after mail is sent

Function: System ensures SNCS communication.

Check method: System treats the condition as error if sub error code (XXXXX) is detected when SNCS auto-sending/manual sending is being performed.

Action: [Retry] button recovers error, and performs re-sending.
[Cancel] button recovers error, and goes back to the previous screen.

6.13.3 SNCS Connection

Description: The following error has occurred.

sub error code (XXXXX)	Details
201	unconnected (offline)
202	receive timeout
203	port open error
204	ETX error
205	BCC error
206	receive error

Function: System ensures SNCS communication.

Check method: System treats the condition as error if sub error code (XXXXX) is detected when SNCS auto-sending/manual sending is being performed.

Action: [Retry] button recovers error, and performs re-sending.
[Cancel] button recovers error, and goes back to the previous screen.

6.13.4 SNCS Setting Error

Description: The following error has occurred

sub error code (XXXXX)	Details
311	length error
312	ETX error

313	BCC error
314	code error
315	receive timeout error
321	system parameter not set
326	DNS server address error
331	parameter not set
332	reserve setting value error
333	IP address error
334	default gateway address error
335	subnet mask error
336	DNS server address error abnormality
341	time/date setting error
342	time zone setting value error
343	host name setting value error
344	mail address (from) error
345	mail address (to) error
346	mail server name error
347	mail server port number error
348	POP server name error
349	POP server port number error
350	POP user name error
351	POP password error
361	mail server name error
362	mail server port number error
363	POP server name error
364	POP server port number error
371	mail parameter error
372	mail title error
373	mail text error
374	mail attachment file error

Function: System ensures SNCS communication.

Check method: System treats the condition as error if sub error code (XXXXX) is detected when SNCS auto-sending/manual sending is being performed.

Action: [Retry] button recovers error, and performs re-sending.
[Cancel] button recovers error, and goes back to the previous screen.

6.13.5 Service Call

Description: A button to notify emergency error has been pressed.

Function: System sends an emergency error to SNCS.

Check method: System treats the condition as error when emergency error button is pressed.

Action: None

6.14 Others

6.14.1 QC(X-bar) Error

Description: The main CPU detects a situation that an Xbar control error occurred.

Function: System ensures that the main unit is under the adequate quality control.

Check method: Statistically performs quality control by using control data. (Control data=the average value of control blood data that are analyzed twice in a row) If the data is not within the control limit, it is assumed to be the Xbar control error.

Action: After all the sequences for the aspirated samples are completed, the system enters the ready mode by pressing [Return] button.

6.14.2 QC(L-J) Error

Description: The main CPU detects a situation that an L-J control error occurred.

Function: System ensures that the main unit is under the adequate quality control.

Check method: Statistically performs quality control using control blood as control data. If the data is not within the control limit, it is assumed to be the L-J control error.

Action: After all the sequences for the aspirated samples are completed, the system enters the ready mode by pressing [Return] button.

6.14.3 Calibration Error

Description: The calibration is performed with much change in values by once.

Function: System ensures that the calibration cannot be performed more than specified by once.

Check method: System treats the condition as error when the calibration change between new and old exceeds 5%, or the calibration value exceeds the range of 80% ~ 120%.

*If the calibration value is in 5%, 80%, or 120%, it is not treated as error.

Action: When the error occurs, the alarm sounds and the input setting value becomes ineffective.

6.15 Pressure value convert table

Refer to the following (1)(2) for the pressure value converting equation. If the value is not listed in the table, perform calculation by calculator.

(1) vacuum y (MPa) = x (mmHg) * 0.000133322 (2) pressure Y (MPa) = X (kg/cm²) * 0.0980665

vacuum non-SI unit (x)	vacuum SI unit (y)	pressure non-SI unit (X)	pressure SI unit (Y)
5 mmHg	0.0007 MPa	0.001 kg/cm ²	0.0001 MPa
10 mmHg	0.0013 MPa	0.003 kg/cm ²	0.0003 MPa
20 mmHg	0.0027 MPa	0.005 kg/cm ²	0.0005 MPa
35 mmHg	0.0047 MPa	0.01 kg/cm ²	0.0010 MPa
100 mmHg	0.0133 MPa	0.03 kg/cm ²	0.0029 MPa
150 mmHg	150 MPa	0.05 kg/cm ²	0.0049 MPa
180 mmHg	0.0240 MPa	0.07 kg/cm ²	0.0069 MPa
200 mmHg	0.0267 MPa	0.1 kg/cm ²	0.0098 MPa
215 mmHg	0.0287 MPa	0.2 kg/cm ²	0.0196 MPa
220 mmHg	0.0293 MPa	0.25 kg/cm ²	0.0245 MPa
230 mmHg	0.0307 MPa	0.27 kg/cm ²	0.0265 MPa
240 mmHg	0.0320 MPa	0.300 kg/cm ²	0.0294 MPa
248 mmHg	0.0331 MPa	0.301 kg/cm ²	0.0295 MPa
250 mmHg	0.0333 MPa	0.33 kg/cm ²	0.0324 MPa
252 mmHg	0.0336 MPa	0.35 kg/cm ²	0.0343 MPa
260 mmHg	0.0347 MPa	0.380 kg/cm ²	0.0373 MPa
270 mmHg	0.0360 MPa	0.400 kg/cm ²	0.0392 MPa
280 mmHg	0.0373 MPa	0.43 kg/cm ²	0.0422 MPa
290 mmHg	0.0387 MPa	0.45 kg/cm ²	0.0441 MPa
298 mmHg	0.0397 MPa	0.47 kg/cm ²	0.0461 MPa
299 mmHg	0.0399 MPa	0.497 kg/cm ²	0.0487 MPa
300 mmHg	0.0400 MPa	0.500 kg/cm ²	0.0490 MPa
380 mmHg	0.0507 MPa	0.510 kg/cm ²	0.0500 MPa
390 mmHg	0.0520 MPa	0.52 kg/cm ²	0.0510 MPa
400 mmHg	0.0533 MPa	0.53 kg/cm ²	0.0520 MPa
415 mmHg	0.0553 MPa	0.55 kg/cm ²	0.0539 MPa
420 mmHg	0.0560 MPa	0.57 kg/cm ²	0.0559 MPa
440 mmHg	0.0587 MPa	0.60 kg/cm ²	0.0588 MPa
450 mmHg	0.0600 MPa	0.605 kg/cm ²	0.0593 MPa
500 mmHg	0.0667 MPa	0.62 kg/cm ²	0.0608 MPa
510 mmHg	0.0680 MPa	0.622 kg/cm ²	0.0610 MPa
530 mmHg	0.0707 MPa	0.650 kg/cm ²	0.0637 MPa
550 mmHg	0.0733 MPa	0.665 kg/cm ²	0.0652 MPa
600 mmHg	0.0800 MPa	0.70 kg/cm ²	0.0686 MPa
		0.701 kg/cm ²	0.0687 MPa
		0.750 kg/cm ²	0.0735 MPa
		1.000 kg/cm ²	0.0981 MPa
		1.030 kg/cm ²	0.1010 MPa
		1.05 kg/cm ²	0.1030 MPa
		1.1 kg/cm ²	0.1079 MPa
		1.5 kg/cm ²	0.1471 MPa
		1.588 kg/cm ²	0.1557 MPa
		1.60 kg/cm ²	0.1569 MPa
		1.601 kg/cm ²	0.1570 MPa

		1.7 kg/cm ²	0.1667 MPa
		1.80 kg/cm ²	0.1765 MPa
		1.9 kg/cm ²	0.1863 MPa
		2.000 kg/cm ²	0.1961 MPa
		2.010 kg/cm ²	0.1971 MPa
		2.1 kg/cm ²	0.2059 MPa
		2.15 kg/cm ²	0.2108 MPa
		2.200 kg/cm ²	0.2157 MPa
		2.240 kg/cm ²	0.2197 MPa
		2.25 kg/cm ²	0.2206 MPa
		2.30 kg/cm ²	0.2256 MPa
		2.4 kg/cm ²	0.2354 MPa
		2.492 kg/cm ²	0.2444 MPa
		2.5 kg/cm ²	0.2452 MPa
		2.513 kg/cm ²	0.2464 MPa
		2.533 kg/cm ²	0.2484 MPa
		2.7 kg/cm ²	0.2648 MPa
		2.8 kg/cm ²	0.2746 MPa
		3.0 kg/cm ²	0.2942 MPa

CHAPTER 7 INSTALLATION

7.1	Installation procedures	1
7.1.1	Initial Operation Sequence	1
7.2	SNCS Settings	1

CHAPTER 7 INSTALLATION

7.1 Installation procedures

Refer to Instructions for Use (Chapter 5: Initial Operation) for unpacking, installation and initial setup procedures at time of delivery.

7.1.1 Initial Operation Sequence

Start the instrument using Hot Start and follow the procedures described below.

- (1) Run the initial operation sequence.
 Select [Service] -> [Service Seq.] -> [Setting Seq.].
 For details of the program, refer to XP Series Service Manual (Chapter 5: Service Program).
- (2) If necessary, set the date.
 Select [Settings] -> [Date/Time].
 For details of the program, refer to Instructions for Use (Chapter 11: Instrument Setup).
- (3) Reset cycle counter.
 Select [Service] -> [Settings] -> [Initialize] -> [Cycle Counter].
 For details of the program, refer to XP Series Service Manual (Chapter 5: Service Program).

Note: When resetting the cycle counter, the date that maintenance was last performed will also be reset. Therefore, set the date first before resetting the cycle counter.

7.2 SNCS Settings

For how to set SNCS settings, refer to the following documents.

- XP Series Service Manual Chapter 5: [5.9 SNCS Settings].
- SNCS Service Manual

 201297: The entire page has been revised.

XP Series Parts List

XP-300 MAIN COMPLETE	8-2
CHASSIS_ASSY NO.100	8-4
KX-21 SRV UNIT COMP.....	8-7
KX-21 SRV UNIT	8-9
DETECTOR BLOCK COMP.KX-21 (XP SERIES)	8-11
DETECTOR BLOCK KX-21 (XP SERIES).....	8-13
REGULATOR UNIT KX-21 (WHITE).....	8-15
PNEUMATIC UNIT KX-21 (XP SERIES)	8-17
PRINTER_ASSY NO.5	8-19
OUTPUT INTERFACE_ASSY NO.6	8-21
DISPLAY_ASSY NO.9	8-23
POWER SUPPLY_ASSY NO.115(EU/230V).....	8-25
CONTROLLER_ASSY NO.81	8-28
FEEDER_ASSY NO.87	8-30
CHAMBER UNIT KX-21.....	8-32
VALVE UNIT-A	8-34
VALVE UNIT-B	8-36
MASTER VALVE 2MV16 ASSY	8-38
COVER_ASSY NO.208(XP-300).....	8-40
COVER_ASSY NO.208(XP-100).....	8-42
WIRING CORDS.....	8-44
HYDRAULIC PARTS.....	8-45
PM PARTS LIST	8-46

XP-300 MAIN COMPLETE

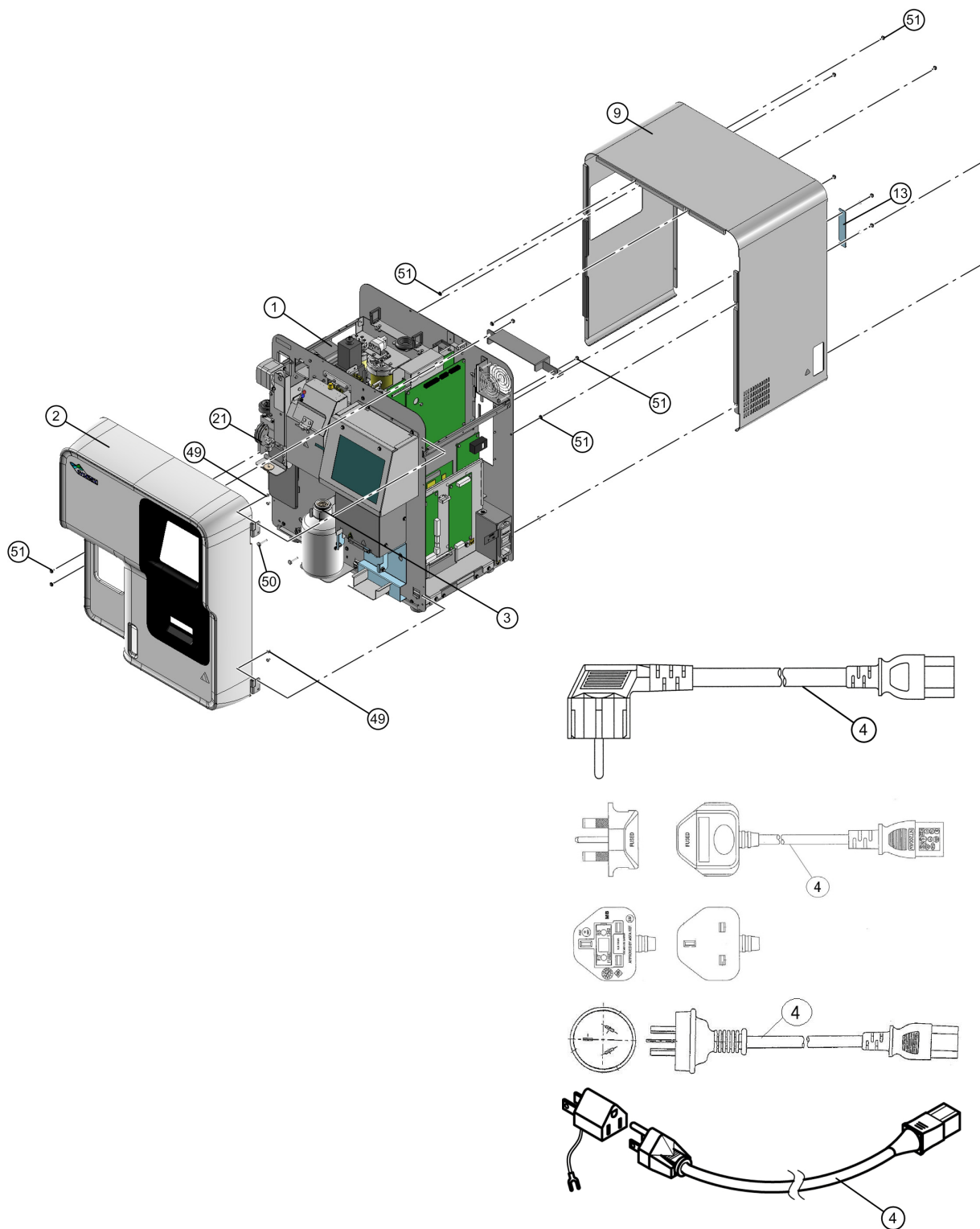

Code No.	Item No.	Description	Unit Q'ty
BJ385377	#	XP-300 MAIN COMPLETE(EU/230V)	
CQ819538	%	XP-300 MAIN COMPLETE(UK/240V)	
AN678469	&	XP-300 MAIN COMPLETE(CHN/220V)	
BQ266940	\$	XP-300 MAIN COMPLETE(EXP/120V)	
AJ263794	1#	CHASSIS_ASSY NO.100(EU/230V)	Unsalable
CN623890	1%	CHASSIS_ASSY NO.100(UK/240V)	Unsalable
AC083677	1&	CHASSIS_ASSY NO.100(CHN/220V)	Unsalable
CN212992	1\$	CHASSIS_ASSY NO.100(EXP/120V)	Unsalable
BQ573054	2	COVER_ASSY NO.208(XP-300)	1
97330417	3	FLOAT SWITCH NO.23 ASSY	1
26571535	4#	POWER CORD TA-6P(A)+TA(A) H05VV-F	1
26547332	4%	POWER CORD NO.7687	1
26571521	4&	POWER CABLE TA-8CH+TA-5(A)	1
92380928	4\$	POWER CORD NO.15 (C-2/N.AMER)	1
A AG089454	9	COVER NO.2670	1
BL083396	10	COVER NO.2827	1
36884544	21	SHEET NO. 4	10
34836120	49	SCREW FLAT M3X6 (SUS)	100
34839334	50	SCREW BINDING M4X20 (SUS)	100
34841015	51	SCREW WITH WASHER (T0.5)M3X8	10

A 201297

CHASSIS_ASSY NO.100

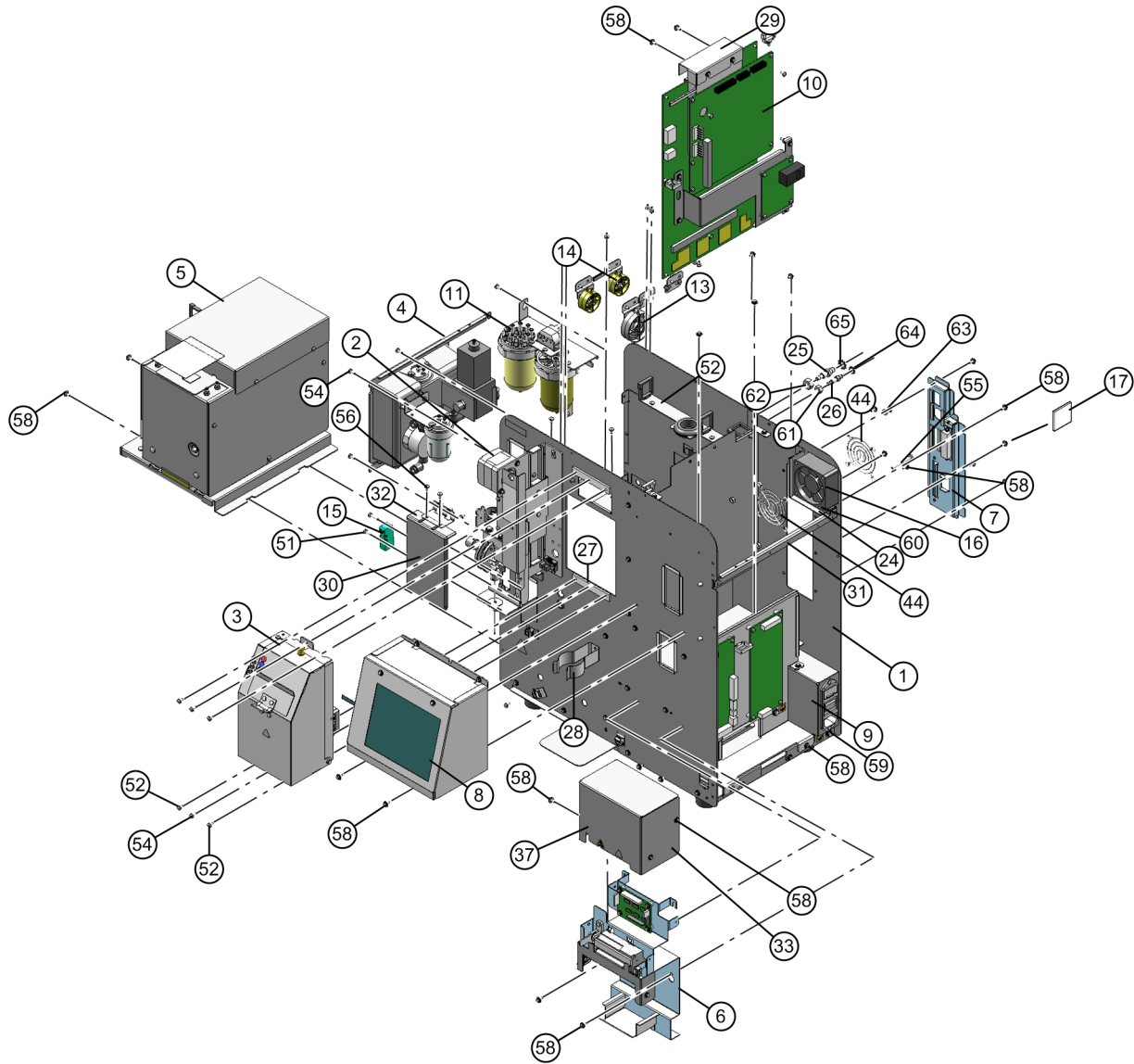

Code No.	Item No.	Description	Unit Q'ty
AJ263794	#	CHASSIS_ASSY NO.100(EU/230V)	
CN623890	%	CHASSIS_ASSY NO.100(UK/240V)	
AC083677	&	CHASSIS_ASSY NO.100(CHN/220V)	
CN212992	\$	CHASSIS_ASSY NO.100(EXP/120V)	
AX424958	1	CHASSIS_ASSY NO.98(XP SERIES)	Unsalable
01343789	2#%	KX-21 SRV UNIT COMP.(K_SRV WHITE_N)	1
01343775	2&\$	KX-21_SRV_ASSY_COMP.(XP SERIES)	1
01344944	3	DETECTOR_BLOCK_COMP.KX-21 (KX)(4)	1
97328927	4	REGULATOR UNIT KX-21 (WHITE)	1
97329842	5	PNEUMATIC UNIT KX-21 (PSL-21Z)(4)	1
AQ668317	6	PRINTER_ASSY NO.5	1
AV600053	7	OUTPUT_INTERFACE_ASSY NO.6	1
CU973306	8	DISPLAY_ASSY NO.9	1
CF438275	9#	POWER_SUPPLY_ASSY NO.115(EU/230V)	1
AH239055	9%	POWER_SUPPLY_ASSY NO.115(UK/240V)	1
AJ787188	9&	POWER_SUPPLY_ASSY NO.115(CHN/220V)	1
BU291768	9\$	POWER_SUPPLY_ASSY NO.115(EXP/120V)	1
CE193444	10	CONTROLLER_ASSY NO.81	1
97329617	11	CHAMBER UNIT KX-21	1
97329013	13	VALVE UNIT-A	1
97329315	14	VALVE UNIT-B	1
92351510	15	SWITCH NO.83 ASSEMBLY	1
93345912	16	FAN ASSEMBLY NO.19	1
BD347455	17	CARD_ASSY NO.25(1XP1X)	1
BC338706	24	SHIELD NO.229	1
44240023	25	NIPPLE NO.122	1
44240037	26	NIPPLE NO.123	1
36416860	27	ISOLATION PLATE NO.15	1
42437434	28	BOTTLE HOLDER NO. 9	1
BV765770	29	SHIELD NO.224	1
CG578306	30	SWITCH NO.24	1
32137061	31	REGULATOR UNIT FRAME	1
BE677908	32	PLATE NO.893	1
AM353957	33	COVER NO.2646	1
CX453674	37	GUIDE NO.1241	1
BQ092757	44	FAN GUARD 8136-TR	1
34839161	51	SCREW BINDING M3X14 (SUS)	100
34838121	52	SCREW BINDING M3X6 (SUS)	100
34839130	54	SCREW BINDING M3X8 (SUS)	100
34839365	55	SCREW BINDING M4X35 (SUS)	100
34840262	56	SCREW TAPPING BINDING M3X6 (SUS)	10
34841015	58	SCREW WITH WASHER (T0.5)M3X8	10
34841081	59	SCREW WITH WASHER (T0.8) M4X8	10
34885140	60	NUT HEX M4 (SUS)	100
34885167	61	NUT HEX M6 (SUS)	100

Code No.	Item No.	Description	Unit Q'ty
34885184	62	NUT HEX M8 X 1.25	10
34895445	63	WASHER TOOTH LOCK EXT M4 (SUS)	100
34895462	64	WASHER TOOTH LOCK EXT M6 (SUS)	50
34895476	65	WASHER TOOTH LOCK EXT M8 (SUS)	100

KX-21 SRV UNIT COMP.

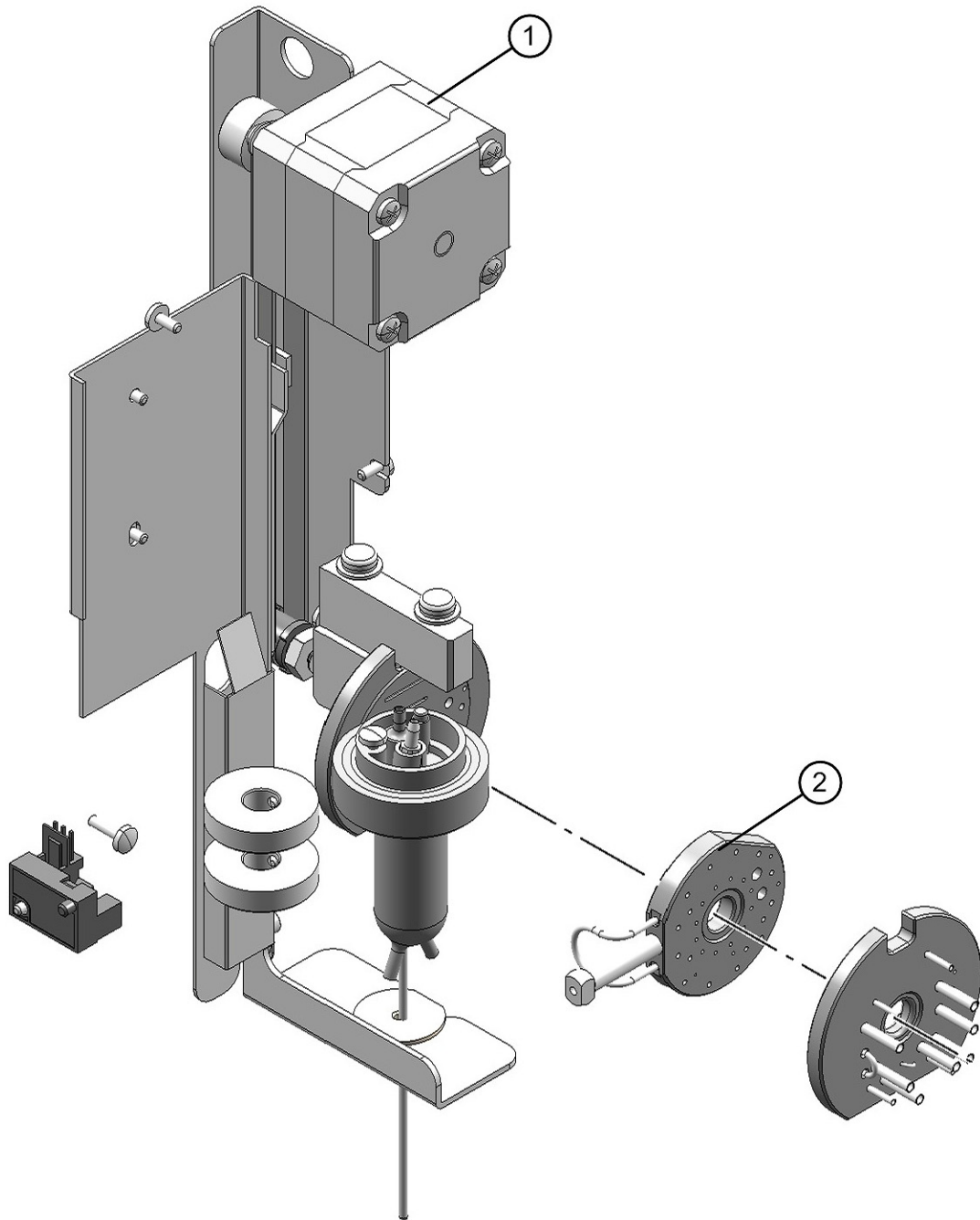

Code No.	Item No.	Description	Unit Q'ty
01343789	#%	KX-21 SRV UNIT COMP.(K_SRV WHITE_N)	1
01343775	&\$	KX-21_SRV_ASSY_COMP.(XP SERIES)	1
97327678	1#%	KX-21 SRV UNIT(K_SRV WHITE_N)	1
97327681	1&\$	SRV UNIT KX-21(S_SRV_WHITE_N)	1
97327921	2#%	SAMPLE ROTOR VALVE NO.17 ASSY (C2)	1
97327935	2&\$	SAMPLE ROTOR VALVE NO.17 ASSY (SYSMEX)	1

#: EU

#: UK

&: CHN

&: NA

KX-21 SRV UNIT

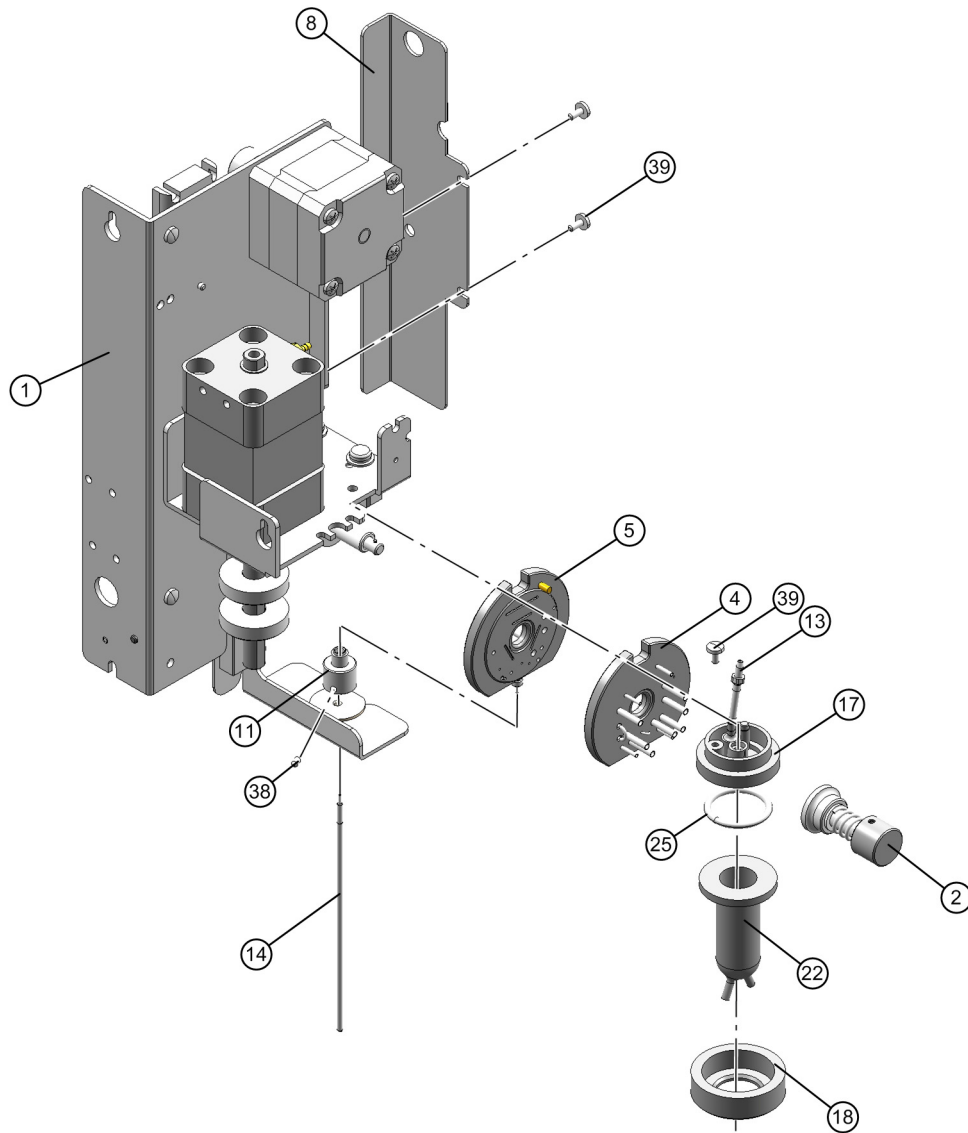

Code No.	Item No.	Description	Unit Q'ty
97327678	#%	KX-21 SRV UNIT(K_SRV WHITE_N)	
01343775	&\$	KX-21_SRV_ASSY_COMP.(XP SERIES)	
97327713	1	DRIVE MECHANISM NO.58(C1/KX21)	1
97327811	2	SAMPLE ROTOR FIXTURE NO. 6	1
97328021	4#%	SRV FIXED VALVE NO.28-L ASSY (C2)	1
97328035	4&\$	SRV FIXED VALVE NO.28-L ASSY (SYSMEX)	1
97328129	5#%	SRV FIXED VALVE NO.28-R ASSY (C2)	1
97328132	5&\$	SRV FIXED VALVE NO.28-R ASSY (SYSMEX)	1
36854801	8	PROTECTION COVER NO. 86	1
34454876	9	FIXING SCREW NO. 18	10
44234608	11	FITTING NO. 9-A	1
44235111	13	NIPPLE NO. 11	10
44116347	14	PIPETTE NO.57	1
36353826	17	FIXING MATERIAL NO.639	1
36350226	18	FIXING MATERIAL NO. 22	1
CW461559	22	CHAMBER NO.244	1
34639183	25	O-RING P-20	10
34849019	38	SCREW HEX-SOCKET M3X4 (SUS)	100
34838121	39	SCREW BINDING M3X6 (SUS)	100

#: EU

#: UK

&: CHN

&: NA

DETECTOR BLOCK COMP.KX-21 (XP SERIES)

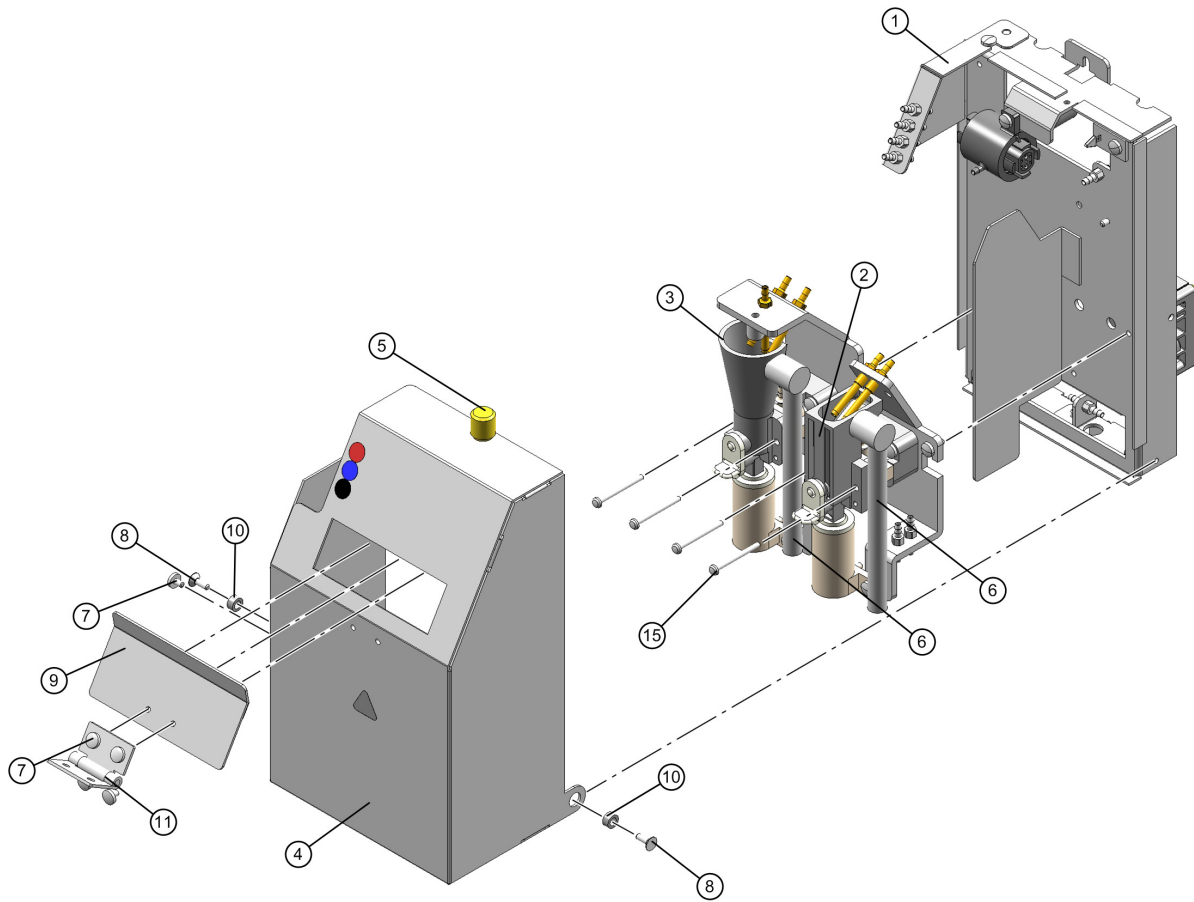

Code No.	Item No.	Description	Unit Q'ty
01344944		DETECTOR BLOCK COMP.KX-21 (XP SERIES)	Unsalable
AB783677	1-	XP DETECTOR BLOCK COMP. (PM) NO.11	1
A 97328243	1	DETECTOR BLOCK KX-21 (XP SERIES)	1
90322912	2	TRANSDUCER NO. 3 ASSY (RBC)	1
97328310	3	TRANSDUCER NO. 8 ASSY	1
32235879	4	DETECTOR BLOCK COVER KX21	1
34455140	5	FIXING SCREW 5-4	10
44284925	6	TUBING NO. 92	1
34839112	7	SCREW BINDING M3X4 (SUS)	100
34836133	8	SCREW FLAT M3X8 (SUS)	100
32225622	9	COVER NO.242	1
36582014	10	SPACER ER- 3	10
BY129688	11	SPRING HINGE B-1046-3	1
34836452	15	SCREW ROUND M2.6X25 (SUS)	50

A 312F045

DETECTOR BLOCK KX-21 (XP SERIES)

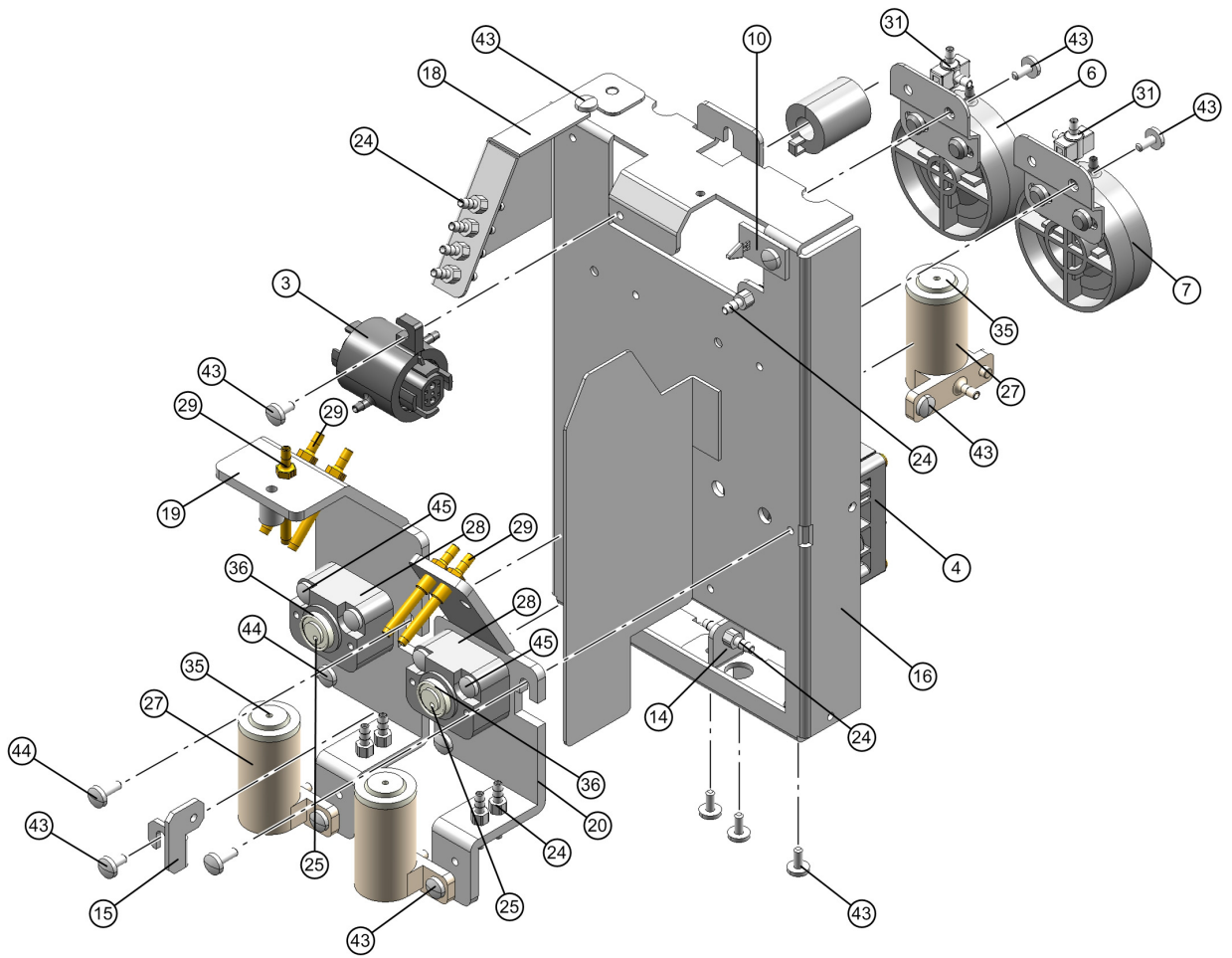

Code No.	Item No.	Description	Unit Q'ty
B 97328243		DETECTOR BLOCK KX-21 (XP SERIES)	
B 97328434	3	HGB UNIT KX-21 (XP SERIES)	1
A 97328514	4	MASTER VALVE 3MV14-AF ASSY	1
A 97328611	5	MASTER VALVE 3MV17-C ASSY	1
96336619	6	DIAPHRAGM PUMP ASSY NO.45(0.5)	1
97328719	7	DIAPHRAGM PUMP ASSY NO.48(0.25)	1
97328816	10	THERMISTOR ASSY NO.37	1
36605865	14	NIPPLE MOUNTING PLATE NO.6	1
36607786	15	CHAMBER MOUNTING PLATE NO.58	1
32337176	16	DETECTOR BLOCK CHASSIS KX	1
36605851	18	NIPPLE MOUNTING PLATE NO.5	1
36607755	19	CHAMBER MOUNTING PLATE NO.55	1
36607769	20	CHAMBER MOUNTING PLATE NO.56	1
44235648	24	NIPPLE NO. 62	1
36719011	25	ELECTRODE NO.38	1
44308370	27	CHAMBER NO.18	1
36713390	28	TRANSDUCER BODY NO.15-A	1
44235759	29	NIPPLE NO. 73	10
44234243	31	HYDRAULIC CONNECTOR NO.14	10
34664511	35	RUBBER SEAL NO. 1	10
34664604	36	RUBBER SEAL NO.10	1
34838121	43	SCREW BINDING M3X6 (SUS)	100
34839130	44	SCREW BINDING M3X8 (SUS)	100
34839161	45	SCREW BINDING M3X14 (SUS)	100
A 312E045		B 312F045	

REGULATOR UNIT KX-21 (WHITE)

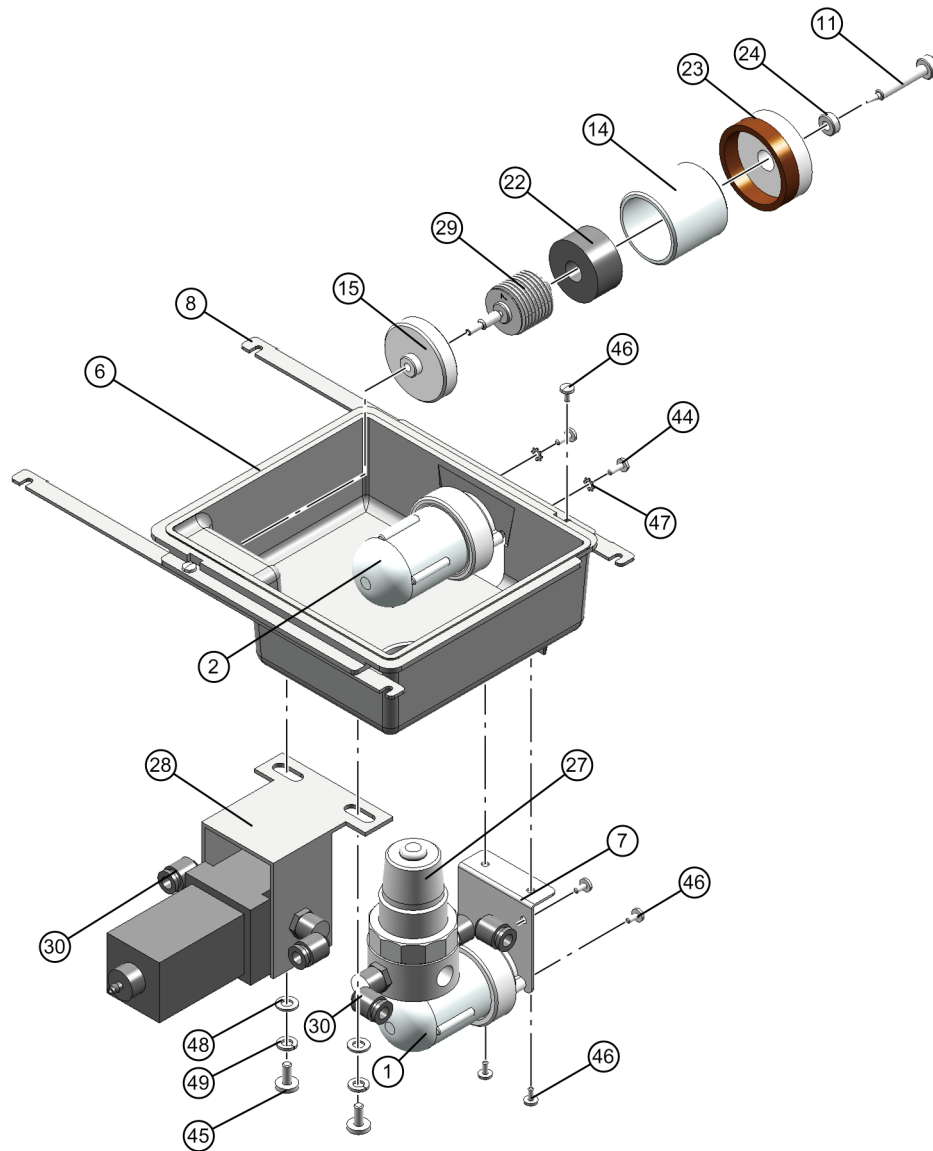

Code No.	Item No.	Description	Unit Q'ty
97328927		REGULATOR UNIT KX-21 (WHITE)	
93334310	1	PU PROTECTION FILTER NO.1 ASSY	1
89350123	2	TRAP CHAMBER NO. 9 ASY (C2/K45	1
AC022458	6	CHASSIS NO.1194	1
32137061	8	REGULATOR UNIT FRAME	1
44310623	11	NEEDLE VALVE NO.2	1
36324803	14	HOLDER NO.29	5
44236532	15	FLANGE 5-3	1
36841397	22	SPONGE ISOLATOR NO.36	10
44313598	23	FILTER NO. 8	1
34476001	24	NEEDLE FIXING NUT	1
44319720	27	RELIEF VALVE 247L4-1VZH	1
AU651830	28	AIR FILTER F1000-6-W	1
36782071	29	BELLOWS WITH METAL NO.7	1
44245829	30	FITTING PL6-01	1
34839130	44	SCREW BINDING M3X8 (SUS)	100
34839542	45	SCREW BINDING M5X10 (SUS)	100
34838121	46	SCREW BINDING M3X6 (SUS)	100
34895431	47	WASHER TOOTH LOCK EXT M3 (SUS)	100
34895050	48	WASHER FLAT M5 (SUS)	100
34895157	49	WASHER SPRING M5 (SUS)	100

PNEUMATIC UNIT KX-21 (XP SERIES)

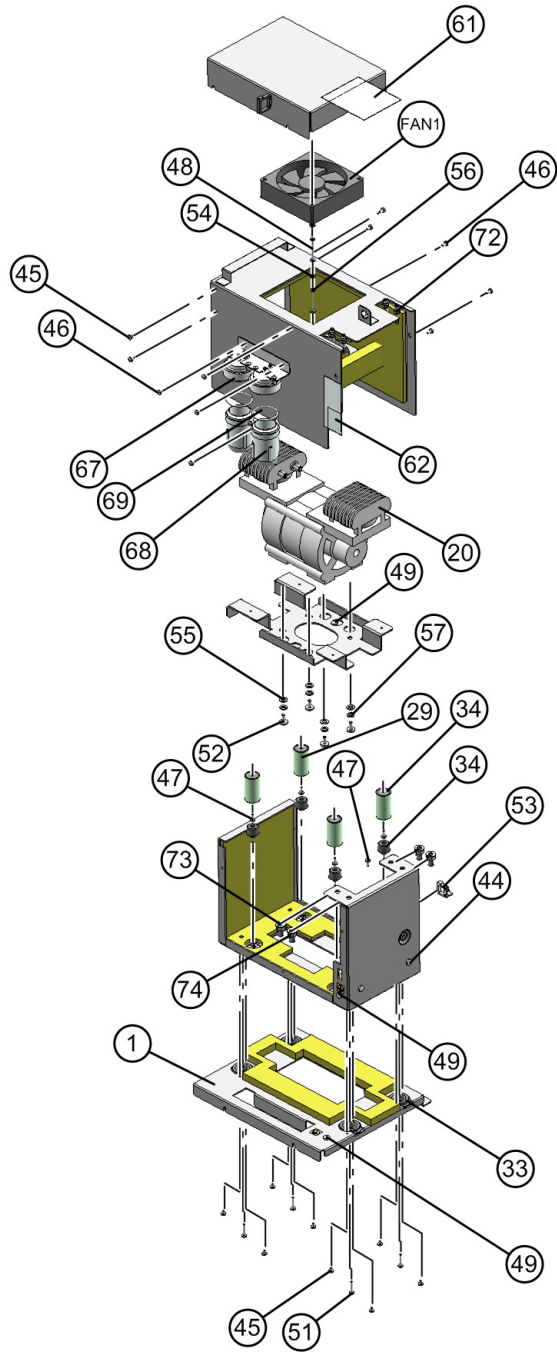

Code No.	Item No.	Description	Unit Q'ty
97329842		PNEUMATIC UNIT KX-21 (XP SERIES)	
AJ971248	1	CHASSIS NO.1303	1
44369537	20	PISTON PUMP PSL-21	1
34522979	29	SPRING NO. 97	1
36807333	33	ANTI-VIBRATION RUBBER KP-32	1
36800095	34	RUBBER SHOE TK-16	10
34839334	44	SCREW BINDING M4X20 (SUS)	100
34839112	45	SCREW BINDING M3X4 (SUS)	100
A 34838121	46	SCREW BINDING M3X6 (SUS)	100
34839130	47	SCREW BINDING M3X8 (SUS)	100
34839210	48	SCREW BINDING M3X30 (SUS)	100
34839268	49	SCREW BINDING M4X6 (SUS)	100
34839174	51	SCREW BINDING M3X16 (SUS)	100
34839542	52	SCREW BINDING M5X10 (SUS)	100
26667482	53	CLAMP LWS-3S	10
34895032	54	WASHER FLAT M3 (SUS)	100
34895050	55	WASHER FLAT M5 (SUS)	100
34895130	56	WASHER SPRING M3 (SUS)	100
34895157	57	WASHER SPRING M5 (SUS)	100
36892790	61	WATER PROOF SHEET NO.97	1
36892804	62	WATER PROOF SHEET NO. 98	1
36516170	67	SUPPORT NO.104	1
44308366	68	CHAMBER NO.17	1
34636111	69	O-RING IN-30 (NITRIL)	100
44240037	72	NIPPLE NO.123	1
34895161	73	WASHER SPRING M6 (SUS)	100
34885167	74	NUT HEX M6 (SUS)	100
A AX576364	FAN1	3610SB-04W-B50-B00 FAN	Unsalable
A AD283587	PM	KIT NO. 244	1
A BH251346	PM	KIT NO. 245	1

A 312J068-R

<NOTE>

- KIT NO. 244 is a fan replacement kit for products that are not applied ECR312J068 and used only the first replacement from old type fan(P/N:28101209) to new type(P/N: AX576364).
- KIT NO. 245 is a fan replacement kit for the products that are applied ECR312J068.

PRINTER_ASSY NO.5

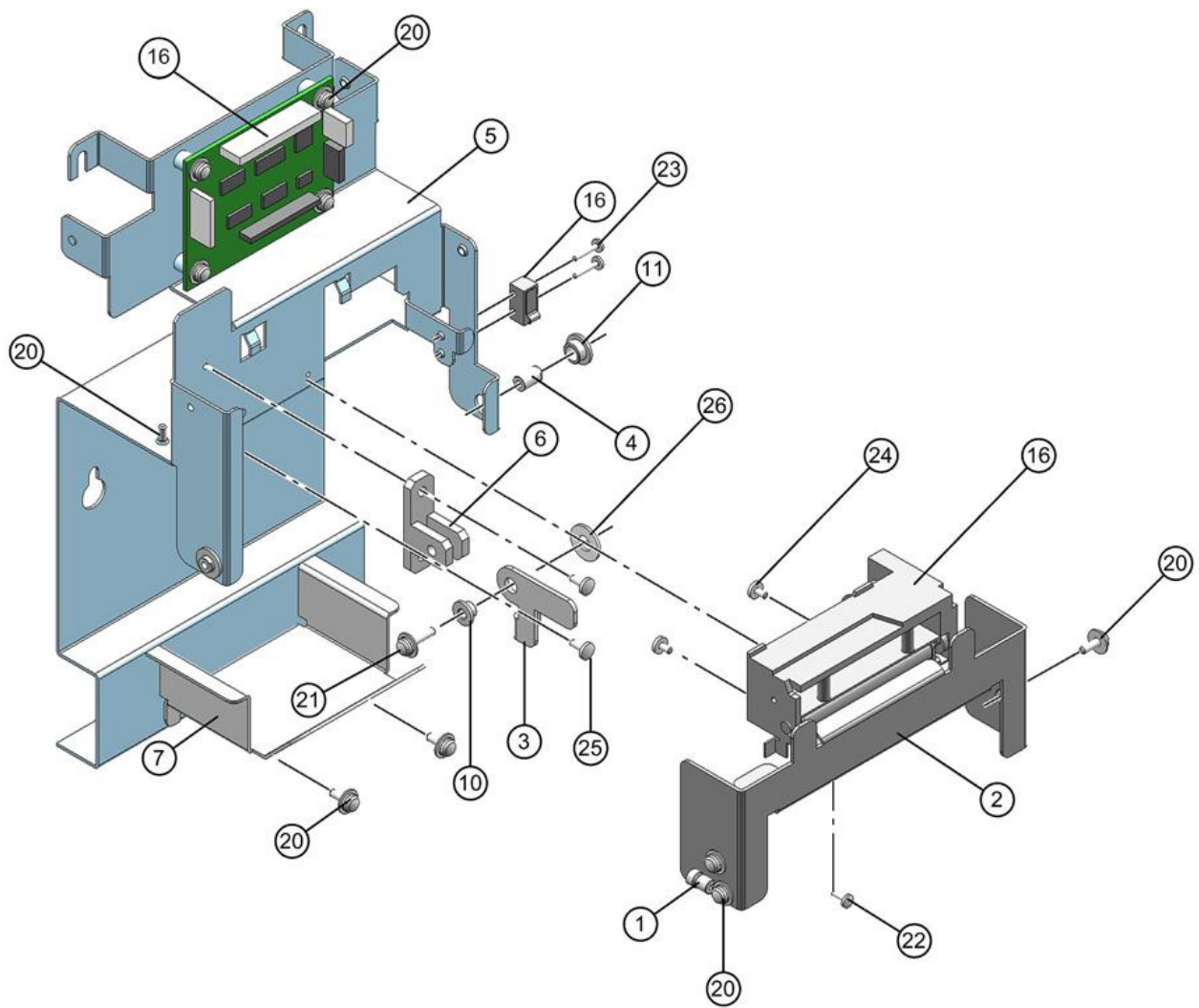

312G034: Changed item numbers 14 and 15 to 16.

Code No.	Item No.	Description	Unit Q'ty
AQ668317		PRINTER_ASSY NO.5	
91305216	1	WIRING CORD NO.1171	1
BG016479	2	COVER NO.2788	1
CS476401	3	KNOB NO.147	1
CC058071	4	PIN NO.211	1
BX933578	5	FRAME NO.1228	1
BW997906	6	MOUNT NO.4740	1
AD876126	7	FRAME NO.1229	1
34149018	10	FLANGE BUSH 80F-0303	1
34149049	11	FLANGE BUSH 80F-0503	1
A AQ049147	14	BD-A1011001 PRINTER CONTROLLER	1
A BQ518368	15	SNS-C1103001 COVER SENSOR	1
A B C AG787184	16	M-T183 PRINTER UNIT	1
C CM446969	16-*	PRINTER(PM) NO.1	1
34841015	20	SCREW WITH WASHER (T0.5)M3X8	10
34841032	21	SCREW WITH WASHER (T0.5)M3X12	10
34839029	22	SCREW BINDING M2X6 (SUS)	100
34839046	23	SCREW BINDING M2X10 (SUS)	100
34838981	24	SCREW BINDING M2.6X4 (SUS)	100
34838977	25	SCREW BINDING M2.6X6 (SUS)	100
34341501	26	WASHER CC-0512-10	1
A 312G034	B 313B057	C 312K053	

16-*: When M-T183 PRINTER UNIT is needed in the field, an order should be placed for PRINTER(PM) NO.1 [P/N: CM446969].

OUTPUT INTERFACE_ASSY NO.6

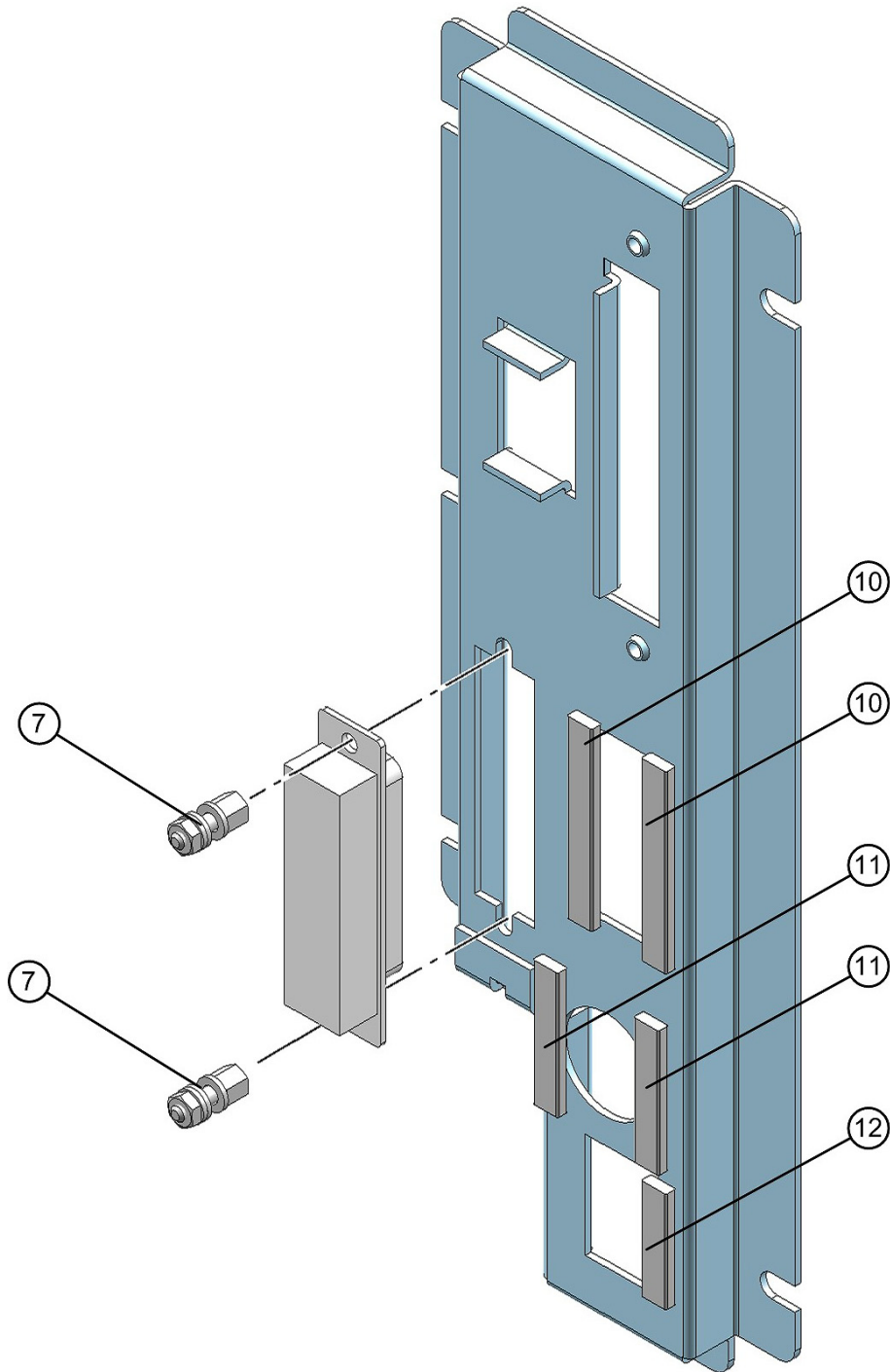

Code No.	Item No.	Description	Unit Q'ty
AV600053		OUTPUT INTERFACE_ASSY NO.6	
26625522	7	LOCK METAL HD-LNA(4-40)(05)	1
AV598916	10	E02S050020RT GASKET	1
AV598916	11	E02S050020RT GASKET	1
AV598916	12	E02S050020RT GASKET	1

DISPLAY_ASSY NO.9

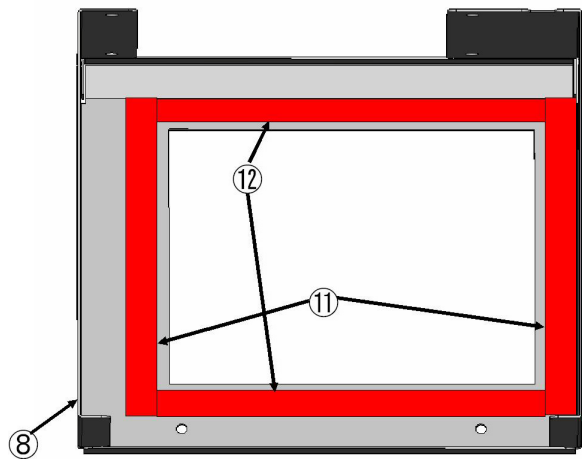
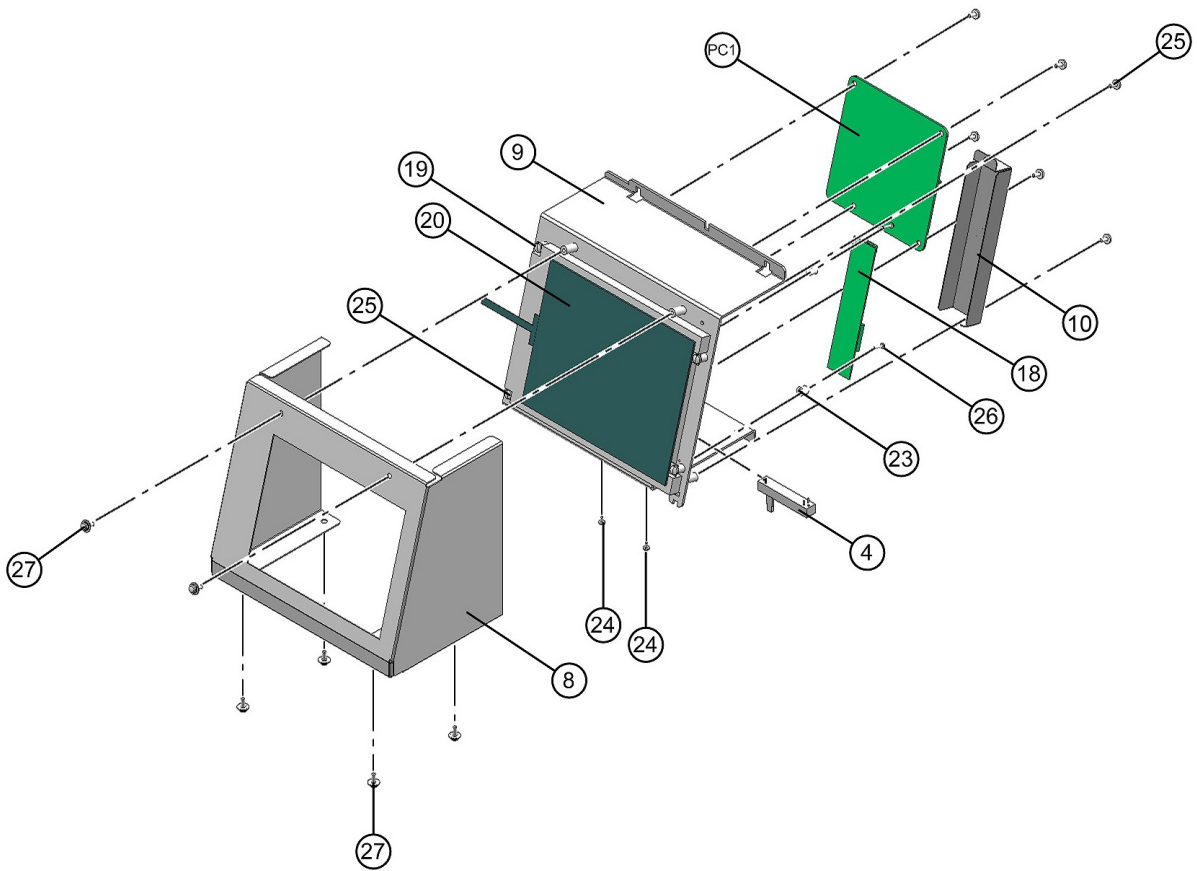

NOTE: PC1 only shows the location of the PCB and does not represent the actual shape of the PCB. A

A 201297

Code No.	Item No.	Description	Unit Q'ty
CU973306		DISPLAY_ASSY NO.9	
01320515	4	VOLUME WITH WIRING NO.22	1
BF199634	8	COVER NO.2758	1
CJ664143	9	CHASSIS NO.1226	1
BN565241	10	COVER NO.2663	1
AK230690	11	SPACER NO.668	1
CU191459	12	SPACER NO.669	1
66393849	18	INVERTOR CXA-L0612A-VJL	1
BM731964	19	LCD MODULE KCG057QV1EA-G030	1
26393303	20	TOUCH PANEL N010-0554-T009	1
36584764	23	SPACER PS-305	100
34839001	24	SCREW BINDING M2X4 (SUS)	100
34838121	25	SCREW BINDING M3X6 (SUS)	100
34838054	26	SCREW ROUND M2X8 (SUS)	100
34841015	27	SCREW WITH WASHER (T0.5)M3X8	10
01321910	PC1	PCB NO.9301	1

POWER SUPPLY_ASSY NO.115(EU/230V)

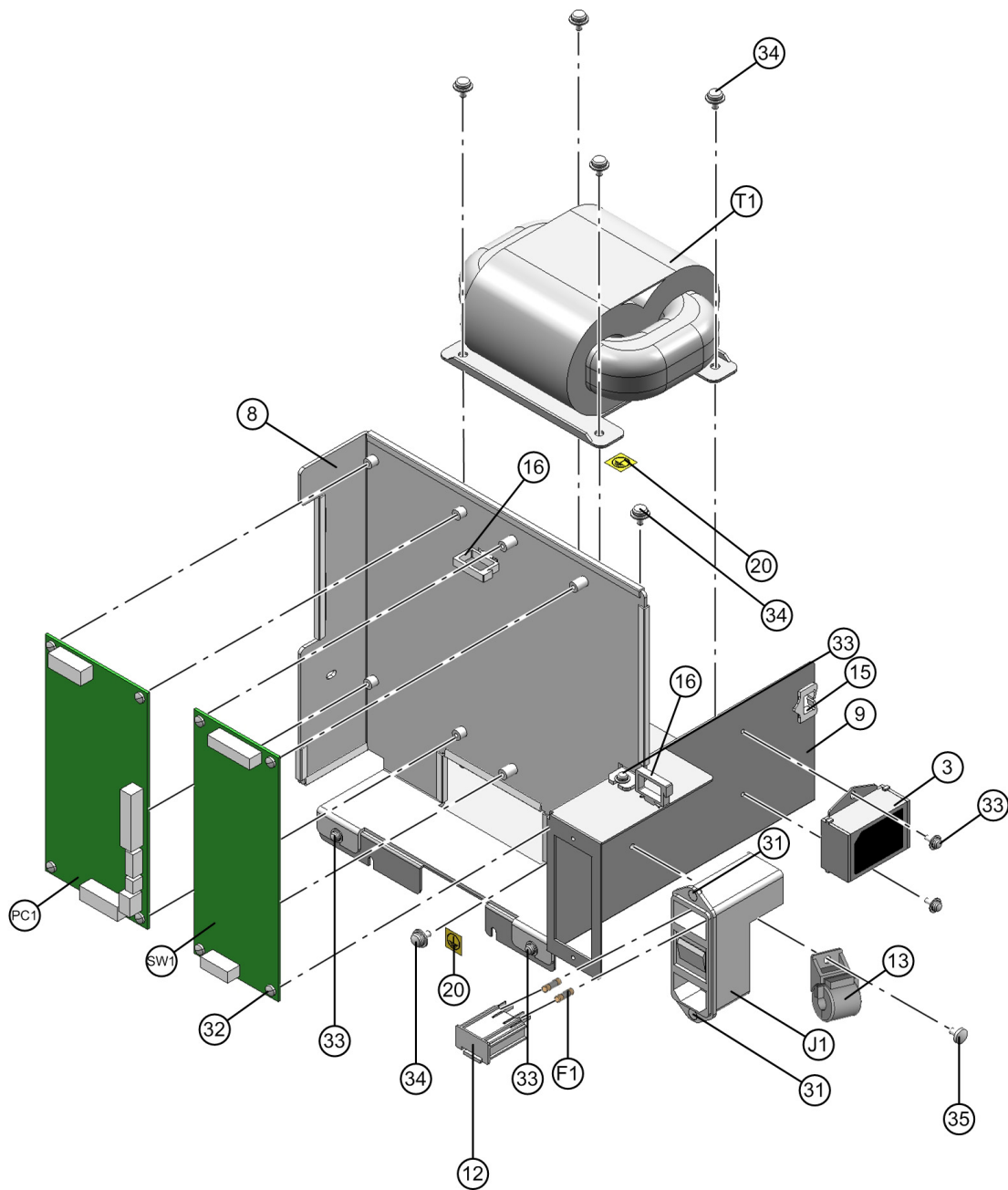

NOTE: PC1 and SW1 only show the locations of the PCBs and do not represent the actual shape of the PCBs. **A**

A 201297

Code No.	Item No.	Description	Unit Q'ty
CF438275		POWER SUPPLY_ASSY NO.115(EU/230V)	
CR905019	3	NOISEFILTER_ASSY NO.2(230V)	1
BY619564	8	CHASSIS NO.1277	1
BN720946	9	CHASSIS_ASSY NO.1276	1
26637017	12	FUSE HOLDER 4303-2401 (EURO+UK	10
B 26671817	13	FERRITE CLAMP TFCK-16-8-16	1
B CH469857	13	GTFCK-16-8-16 FERRITECORE	1
A 26663721	15	CLAMP EDS-1208U	100
A 26667479	16	CLAMP LWS-3S-2W	50
36958401	20	INDICATION MARK NO.841	10
34836120	31	SCREW FLAT M3X6 (SUS)	100
34838121	32	SCREW BINDING M3X6 (SUS)	100
34841015	33	SCREW WITH WASHER (T0.5)M3X8	10
34841081	34	SCREW WITH WASHER (T0.8) M4X8	10
34839268	35	SCREW BINDING M4X6 (SUS)	100
26636757	J1	AC INLET KD14.1101.151	1
AX880901	F1	50T032H FUSE	1
AY107146	PC1	PCB NO.4087T1(XP SERIES)	1
BK069207	SW1	POWER SUPPLY LFA100F-12-J1Y	1
CS177111	T1	TRANSFORMER POWER PT-115	1

Code No.	Item No.	Description	Unit Q'ty
AH239055		POWER SUPPLY_ASSY NO.115(UK/240V)	
BS442303	3	NOISEFILTER_ASSY NO.2(240V)	1
BY619564	8	CHASSIS NO.1277	1
BN720946	9	CHASSIS_ASSY NO.1276	1
26637017	12	FUSE HOLDER 4303-2401 (EURO+UK	10
B 26671817	13	FERRITE CLAMP TFCK-16-8-16	1
B CH469857	13	GTFCK-16-8-16 FERRITECORE	1
A 26663721	15	CLAMP EDS-1208U	100
A 26667479	16	CLAMP LWS-3S-2W	50
36958401	20	INDICATION MARK NO.841	10
34836120	31	SCREW FLAT M3X6 (SUS)	100
34838121	32	SCREW BINDING M3X6 (SUS)	100
34841015	33	SCREW WITH WASHER (T0.5)M3X8	10
34841081	34	SCREW WITH WASHER (T0.8) M4X8	10
34839268	35	SCREW BINDING M4X6 (SUS)	100
26636757	J1	AC INLET KD14.1101.151	1
AX880901	F1	50T032H FUSE	1
AY107146	PC1	PCB NO.4087T1(XP SERIES)	1
BK069207	SW1	POWER SUPPLY LFA100F-12-J1Y	1
CS177111	T1	TRANSFORMER POWER PT-115	1

A 201297 **B** 313D070

Code No.	Item No.	Description	Unit Q'ty
AJ787188		POWER SUPPLY_ASSY NO.115(CHN/220V)	
CC069195	3	NOISEFILTER_ASSY NO.2(220V)	1
BY619564	8	CHASSIS NO.1277	1
BN720946	9	CHASSIS_ASSY NO.1276	1
26637017	12	FUSE HOLDER 4303-2401 (EURO+UK)	10
B 26671817	13	FERRITE CLAMP TFCK-16-8-16	1
B CH469857	13	GTFCK-16-8-16 FERRITECORE	1
A 26663721	15	CLAMP EDS-1208U	100
A 26667479	16	CLAMP LWS-3S-2W	50
36958401	20	INDICATION MARK NO.841	10
34836120	31	SCREW FLAT M3X6 (SUS)	100
34838121	32	SCREW BINDING M3X6 (SUS)	100
34841015	33	SCREW WITH WASHER (T0.5)M3X8	10
34841081	34	SCREW WITH WASHER (T0.8) M4X8	10
34839268	35	SCREW BINDING M4X6 (SUS)	100
26636757	J1	AC INLET KD14.1101.151	1
AX880901	F1	50T032H FUSE	1
AY107146	PC1	PCB NO.4087T1(XP SERIES)	1
BK069207	SW1	POWER SUPPLY LFA100F-12-J1Y	1
CS177111	T1	TRANSFORMER POWER PT-115	1

Code No.	Item No.	Description	Unit Q'ty
BU291768		POWER SUPPLY_ASSY NO.115(EXP/120V)	
BN671730	3	NOISEFILTER_ASSY NO.2(120V)	1
BY619564	8	CHASSIS NO.1277	1
BN720946	9	CHASSIS_ASSY NO.1276	1
26637021	12	FUSE HOLDER 4303-2901 (N.AMER)	10
B 26671817	13	FERRITE CLAMP TFCK 16 8 16	1
B CH469857	13	GTFCK-16-8-16 FERRITECORE	1
A 26663721	15	CLAMP EDS-1208U	100
A 26667479	16	CLAMP LWS-3S-2W	50
36958401	20	INDICATION MARK NO.841	10
34836120	31	SCREW FLAT M3X6 (SUS)	100
34838121	32	SCREW BINDING M3X6 (SUS)	100
34841015	33	SCREW WITH WASHER (T0.5)M3X8	10
34841081	34	SCREW WITH WASHER (T0.8) M4X8	10
34839268	35	SCREW BINDING M4X6 (SUS)	100
26636757	J1	AC INLET KD14.1101.151	1
26650113	F1	FUSE 250V4A ST4-4A-N1 (N.AMER)	10
AY107146	PC1	PCB NO.4087T1(XP SERIES)	1
BK069207	SW1	POWER SUPPLY LFA100F-12-J1Y	1
CA878955	T1	TRANSFORMER POWER PT-114	1

A 201297 B 313D070

CONTROLLER_ASSY NO.81

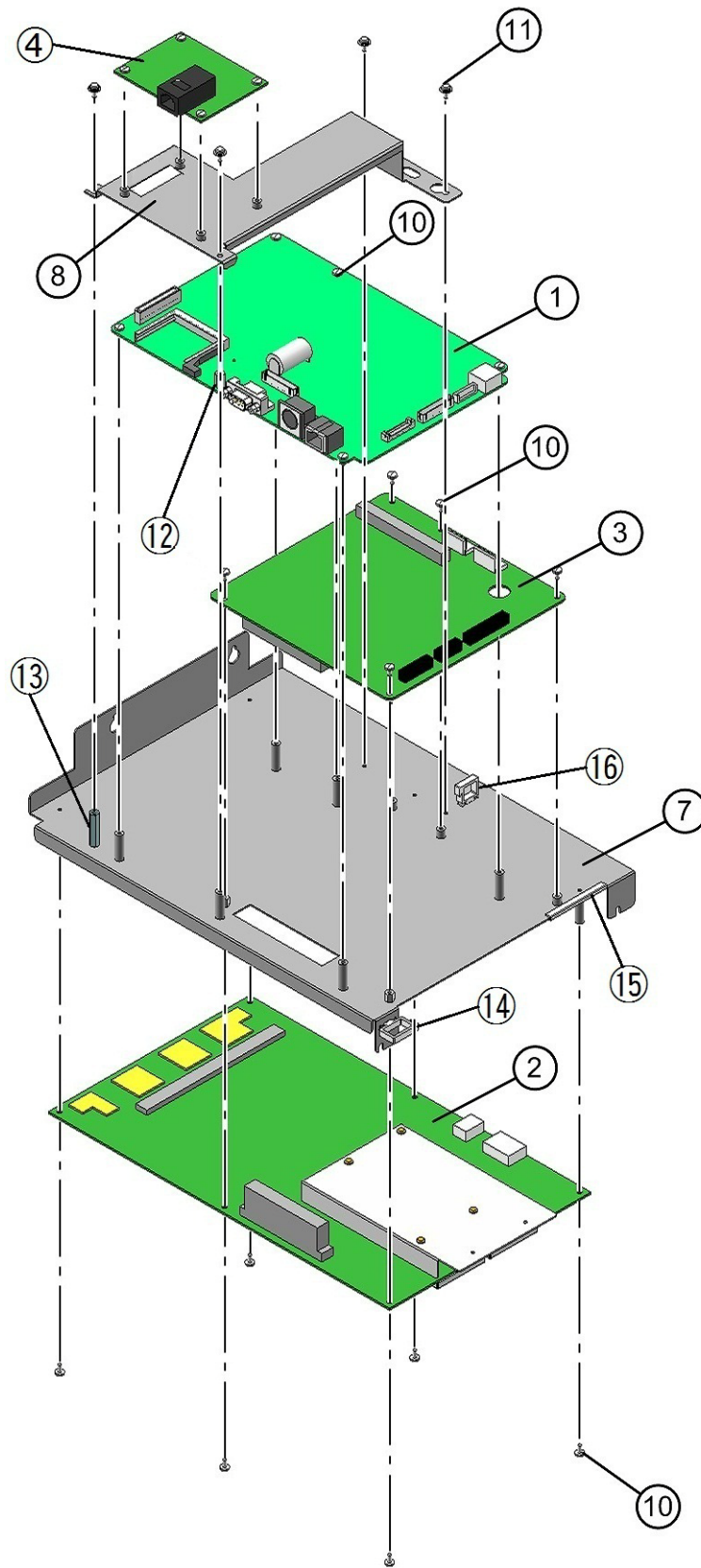

A 312I034: The entire diagram has been updated.

Code No.	Item No.	Description	Unit Q'ty
CE193444		CONTROLLER_ASSY NO.81	1
01321861	1	PCB NO.6374(RU2D)	1
AW548638	2	PCB NO.2135 COMP.	1
B AG620580	2*	PCB NO.20034 (XP/KX)	1
AP968241	3	PCB NO.30012(XP SERIES)	1
BY569881	4	PCB NO.90043(XP SERIES)	1
97330816	7	MOUNT NO.4409	1
BC506772	8	MOUNT NO.4815	1
AA479823	10	SCREW BINDING M3X6 (SUS)	100
34838121	11	SCREW WITH WASHER (T0.5)M3X8	10
34841015	12	SPACER S6BB-310E	5
36586335	13	SPACER S6BB-325E	5
36586432	14	CLAMP LWS-3S-2W	50
26667479	15	BUSH FREE SIZE CE-012W	5
26663081	16	CLAMP LWS-3S	10

A 312I034 **B** 312J003

FEEDER_ASSY NO.87

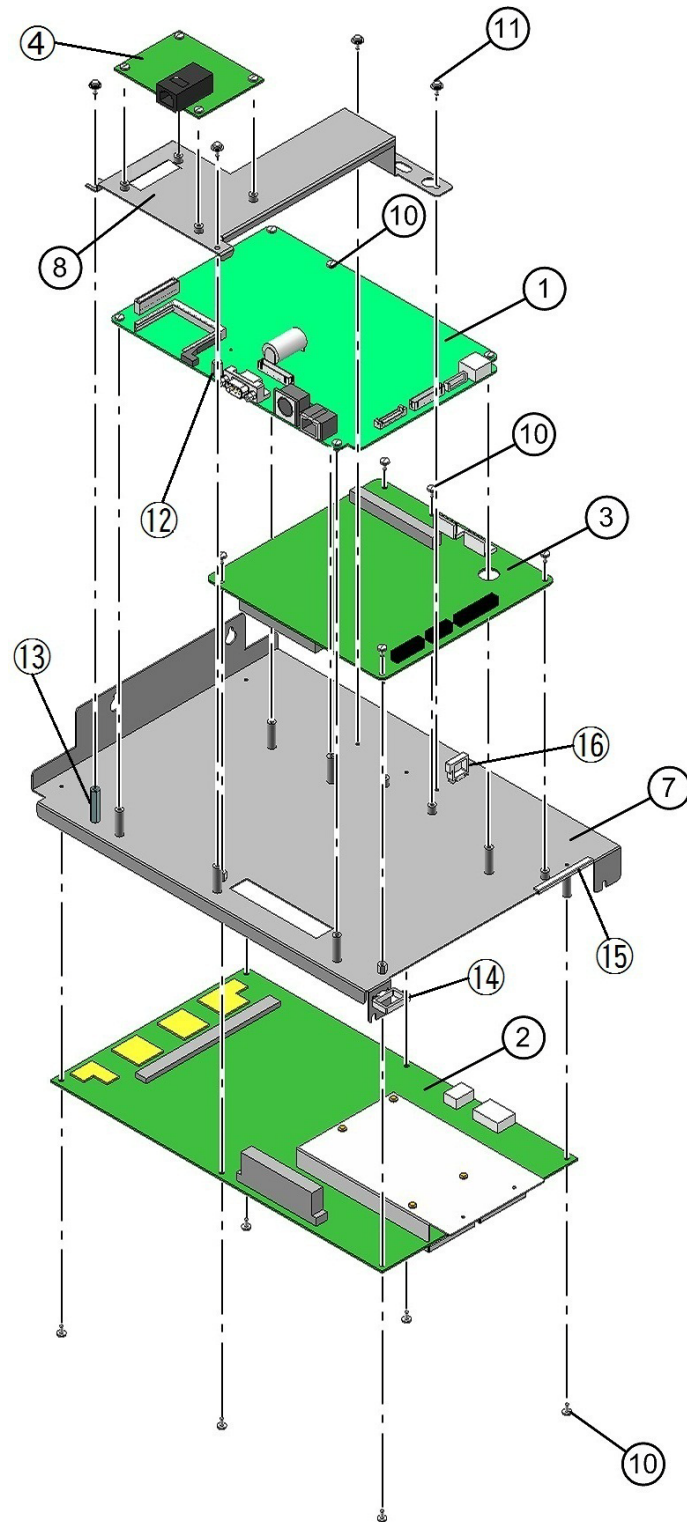

Code No.	Item No.	Description	Unit Q'ty
CE193444		CONTROLLER_ASSY NO.81	1
1321861	1*	PCB NO.6374(RU-20)	1
AW548638	2	PCB NO.2135 COMP.	1
AP968241	3	PCB NO.30012(XP SERIES)	1
BC506772	7	MOUNT NO.4409	1
AA479823	8	MOUNT NO.4815	1
34838121	10	SCREW BINDING M3X6 (SUS)	100
34841015	11	SCREW WITH WASHER (T0.5)M3X8	10

* PCB No. 6374 must be used with white maker on M24 (TL16C552AFN) as shown.

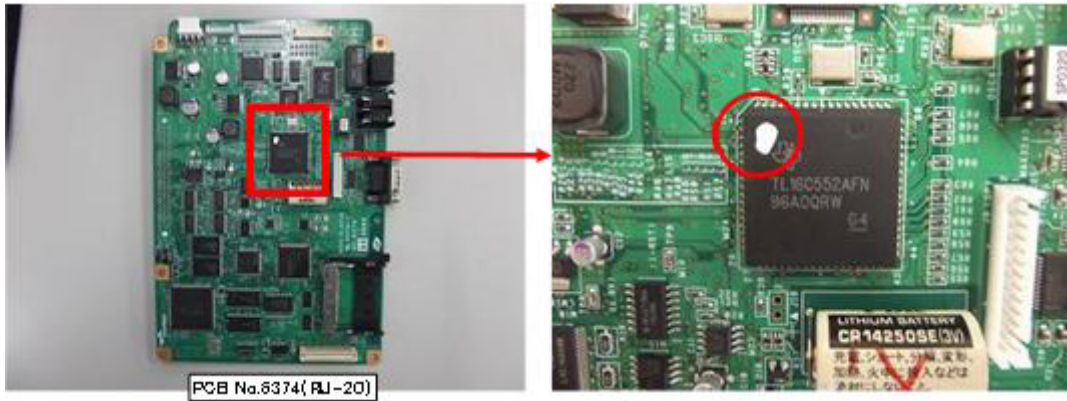

CHAMBER UNIT KX-21

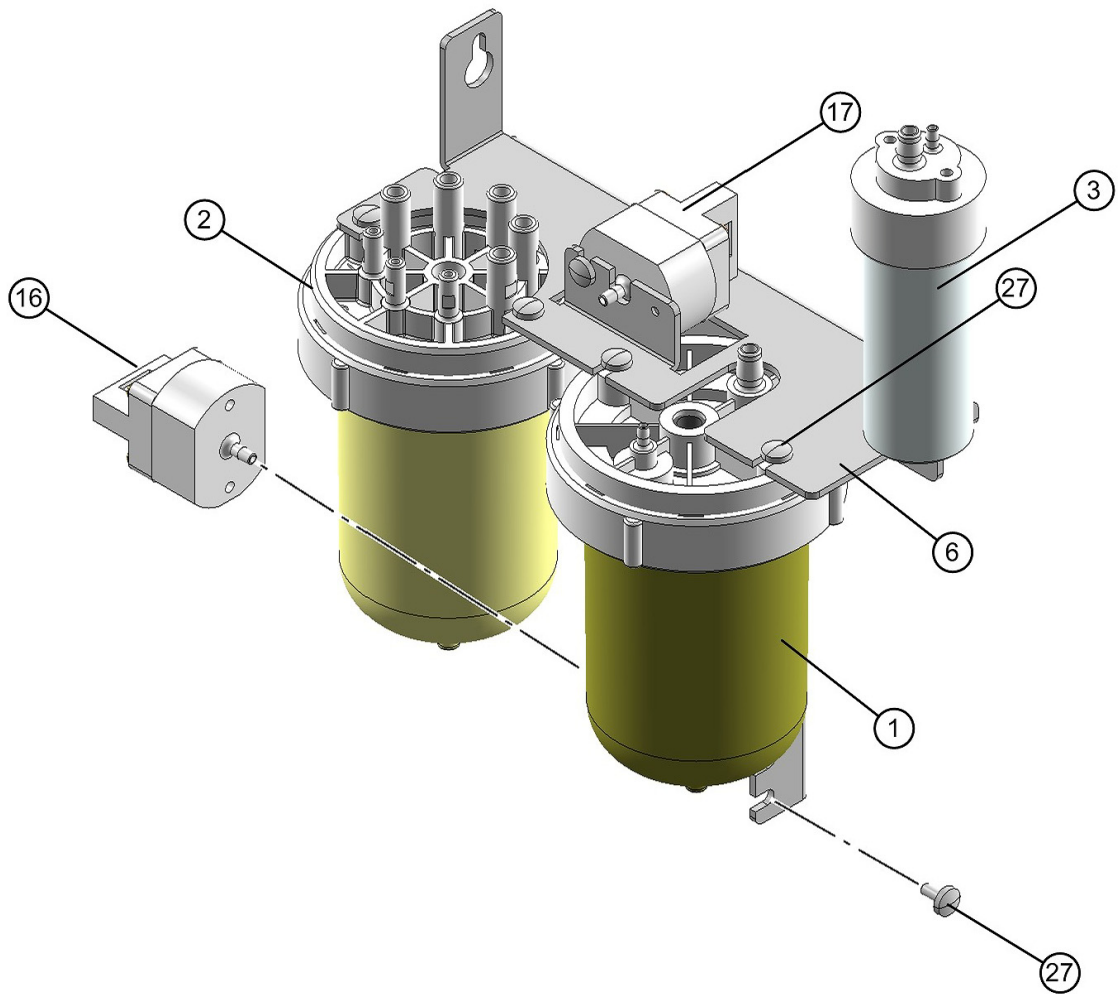

Code No.	Item No.	Description	Unit Q'ty
97329617		CHAMBER UNIT KX-21	
91309270	1	DILUENT CHAMBER NO.10 (C-7)	1
96333470	2	WASTE CHAMBER NO.35 (C-7/XN SERIES)	1
96303611	3	TRAP CHAMBER NO.21 ASSY (C-1)	1
36607741	6	CHAMBER MOUNTING PLATE NO.54	1
BV599050	16	VALVE ASSY NO.140	1
44312926	17	PINCH VALVE K-3 ASSY	1
34838121	27	SCREW BINDING M3X6 (SUS)	100

VALVE UNIT-A

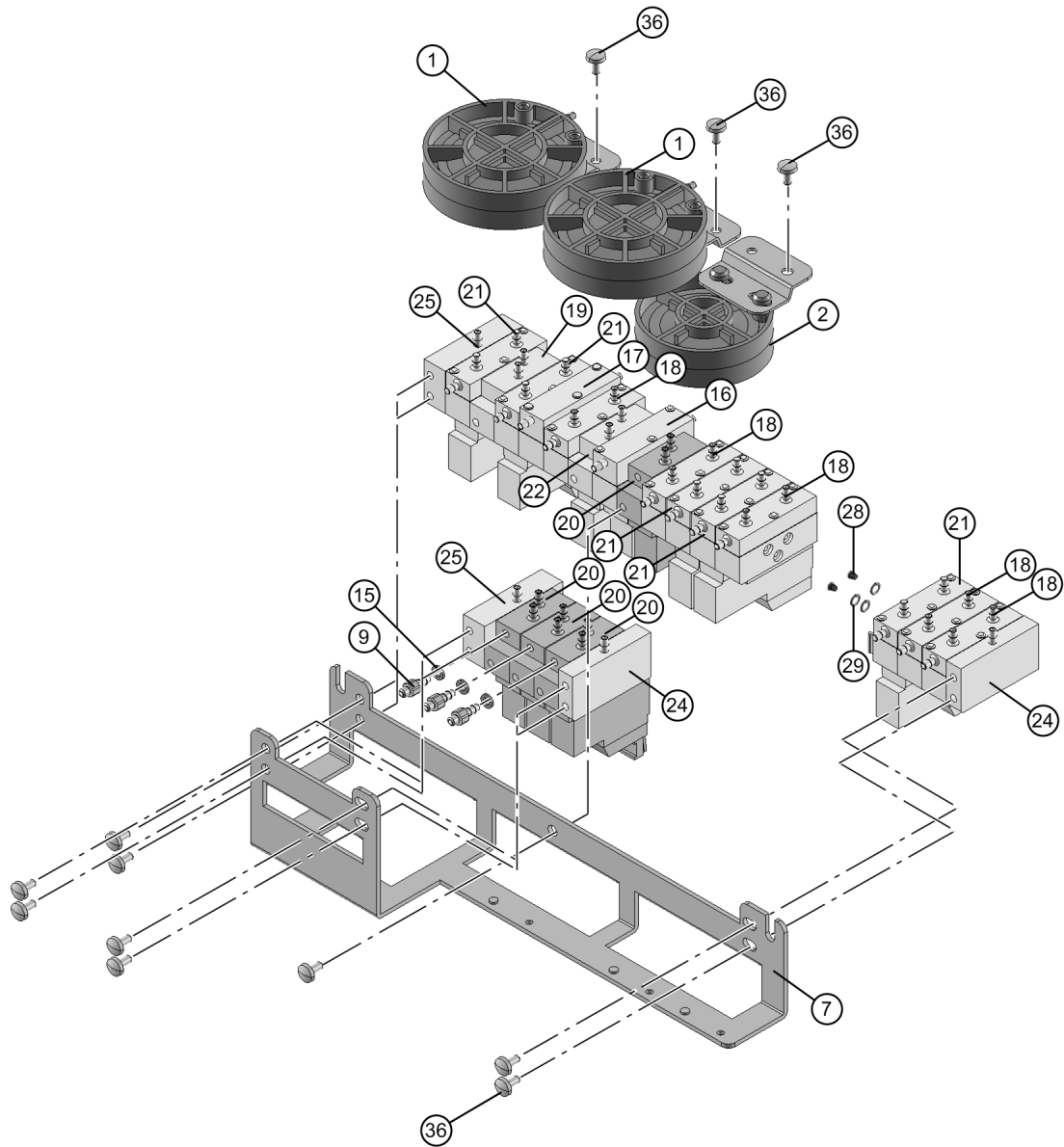

Connection Chart

Note) 1 ▷ O-RING CR560W

▶ O-RING CR560W and PLUG CR554W

× Both O-Ring and PLUG CR554W are not inserted.

Note) 2 → Top Line

▷ Middle Line

▶ Bottom Line

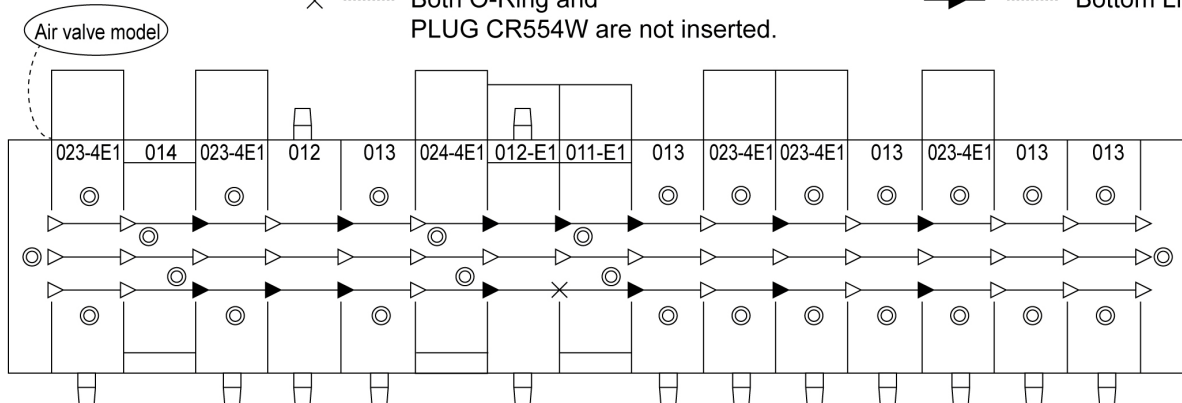

Code No.	Item No.	Description	Unit Q'ty
97329013		VALVE UNIT-A	
97329111	1	DIAPHRAGM PUMP NO.49 (2.0 CC)	1
97329218	2	DIAPHRAGM PUMP ASSY NO.50 1.0CC	1
36630775	7	VAVLE FIXTURE NO.55	1
44235092	9	NIPPLE NO. 9	10
34665661	15	SEAL NO.16	10
44396798	16	AIR VALVE WTKV012-E1-EPDM-PLL DC12V	1
44396784	17	AIR VALVE WTKV012-EPD	1
44396851	18	AIR VALVE WTKV013-EPDM	1
44396501	19	AIR VALVE WTKV014	1
44386604	20	AIR VALVE WTKV011- E1-PLL-DC12	1
44396881	21	AIR VALVE WTKV023-4E1-EPDM-PLL DC12V	1
44396580	22	AIR VALVE WTKV024-4E1-PLL-DC12	1
44386621	24	END PLATE WTKV010-R	1
44386635	25	END PLATE WTKV010-L	1
44291506	28	PLUG CR554W	10
34635036	29	O-RING CR560W	10
34838121	36	SCREW BINDING M3X6 (SUS)	100

VALVE UNIT-B

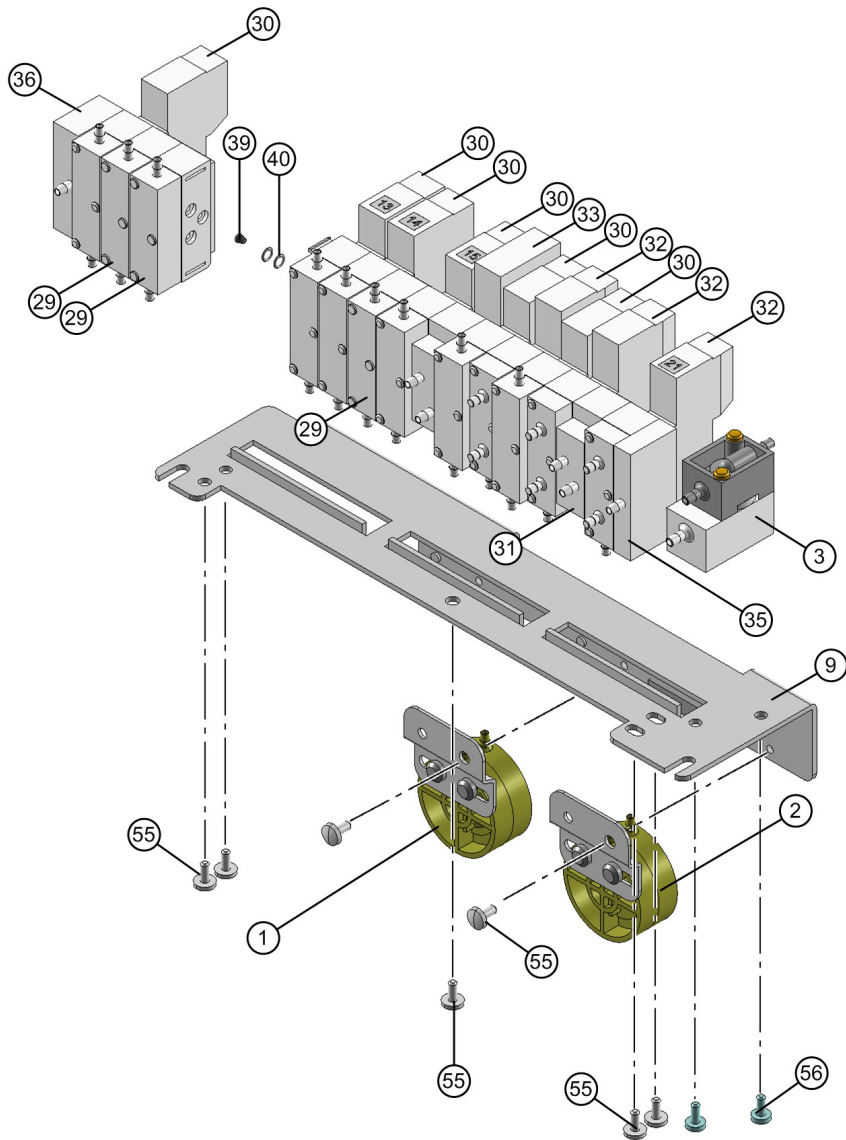

Connection Chart

Note) 1 ▷ O-RING CR560W

▶ O-RING CR560W and PLUG CR554W

× Both O-Ring and PLUG CR554W are not inserted.

Note) 2 —▶ Top Line

—▶ Middle Line

—▶ Bottom Line

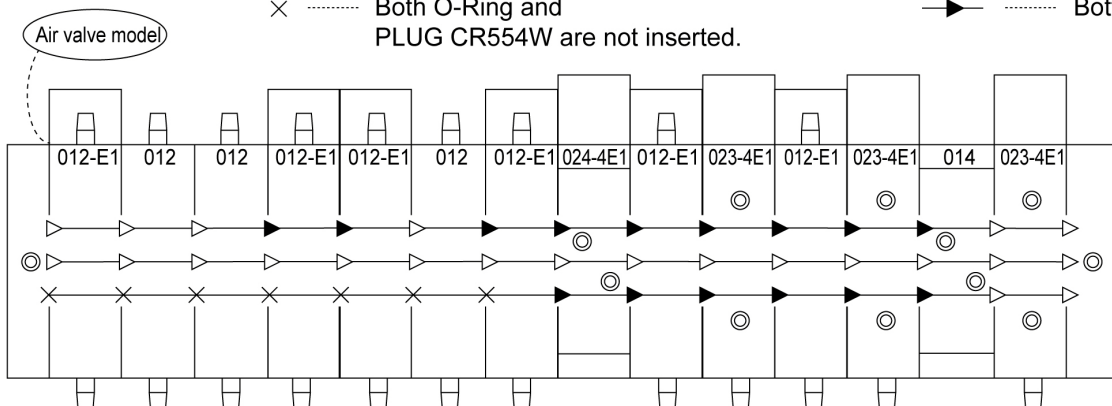

Code No.	Item No.	Description	Unit Q'ty
97329315		VALVE UNIT-B	
97329412	1	DIAPHRAGM PUMP ASSY NO.51(0.2)	1
97329510	2	DIAPHRAGM PUMP ASSY NO.52(0.05)	1
87320011	3	MASTER VALVE 2MV16 ASSY	1
36630758	9	VALVE FIXTURE NO.53	1
44396784	29	AIR VALVE WTKV012-EPD	1
44396798	30	AIR VALVE WTKV012-E1-EPDM-PLL DC12V	1
44396501	31	AIR VALVE WTKV014	1
44396881	32	AIR VALVE WTKV023-4E1-EPDM-PLL DC12V	1
44396580	33	AIR VALVE WTKV024-4E1-PLL-DC12	1
44386621	35	END PLATE WTKV010-R	1
44386635	36	END PLATE WTKV010-L	1
44291506	39	PLUG CR554W	10
34635036	40	O-RING CR560W	10
34838121	55	SCREW BINDING M3X6 (SUS)	100
34858256	56	SCREW TAP-TIGHT M3X6	10

MASTER VALVE 2MV16 ASSY

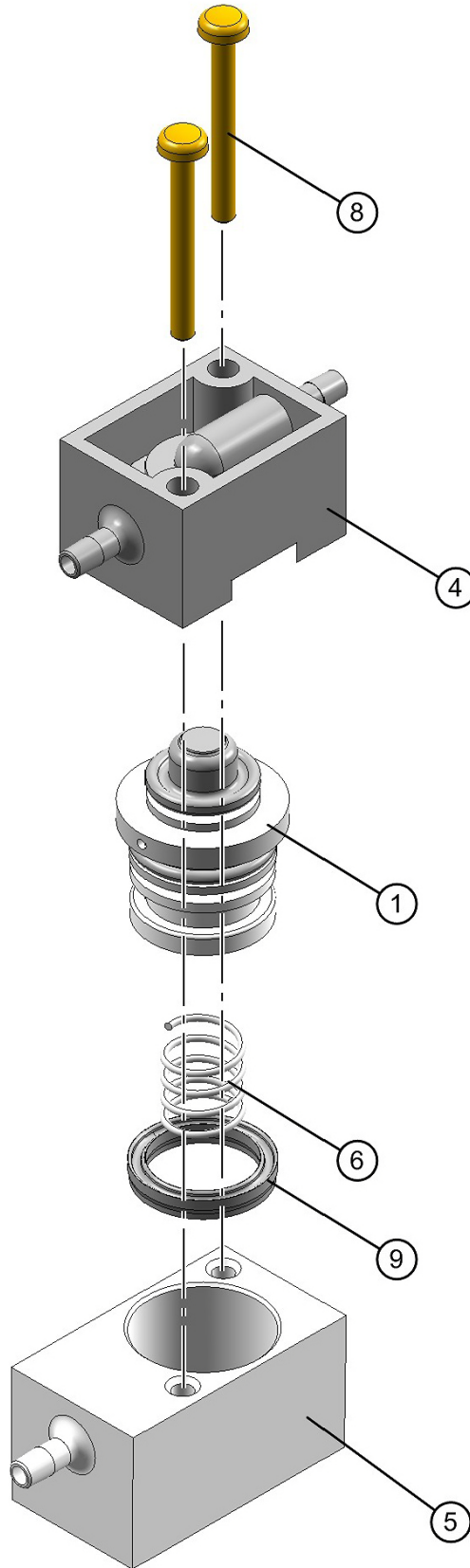

Code No.	Item No.	Description	Unit Q'ty
87320011		MASTER VALVE 2MV16 ASSY	
87303516	1	CYLINDER UNIT NO. 6-L	10
44311486	4	VALVE SEAL NO. 8	10
44315682	5	MANIFOLD NO.68	1
34522629	6	SPRING NO. 62	10
34813109	8	SCREW ROUND M2.6X20 (BS)	100
34625109	9	MINI-Y PACKING MY-10	10

COVER_ASSY NO.208(XP-300)

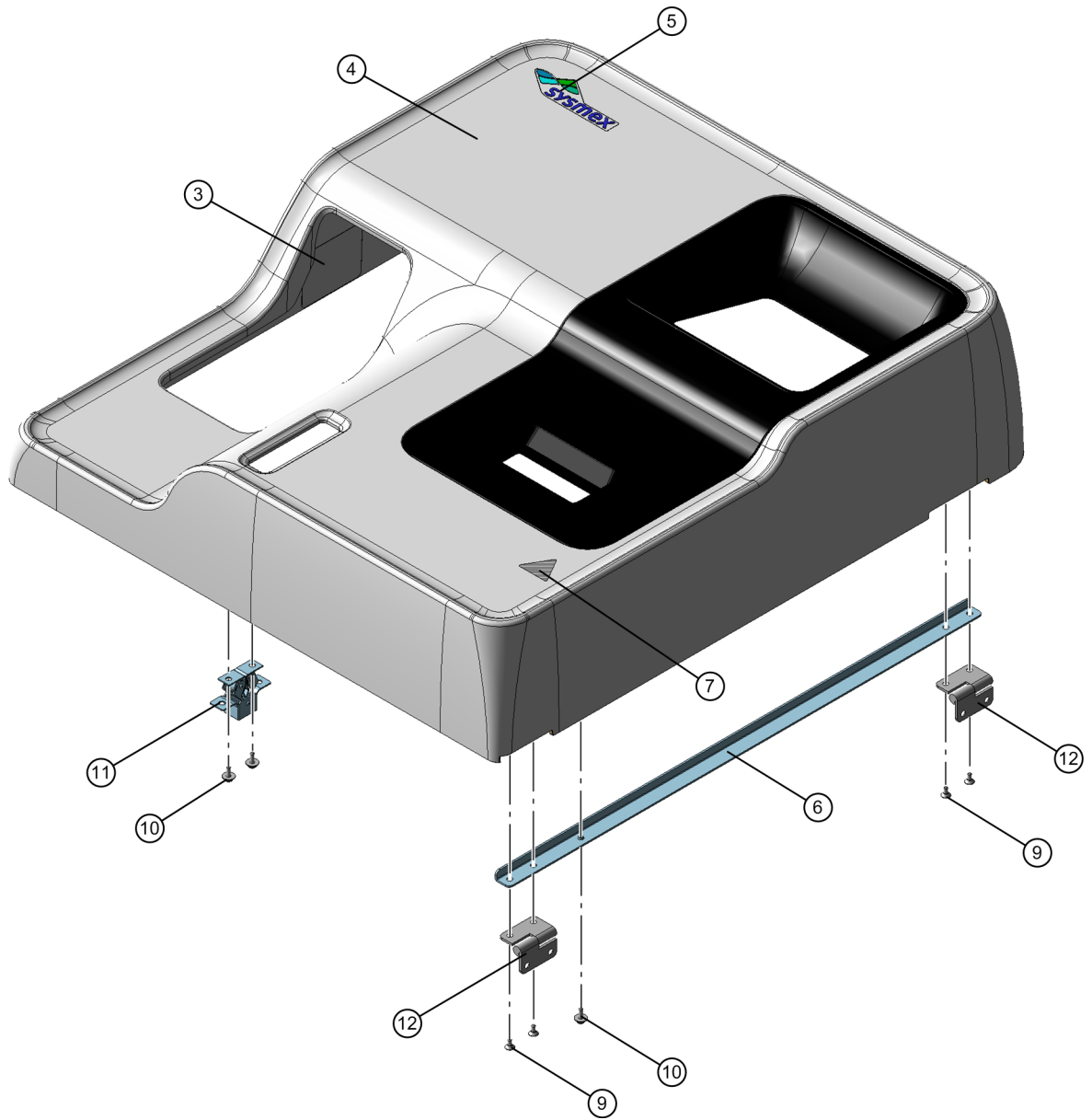

Code No.	Item No.	Description	Unit Q'ty
BQ573054		COVER_ASSY NO.208(XP-300)	
36884863	3	SHEET NO.34	1
CF349896	4	COVER NO.2667	1
BP777121	6	MOUNT NO.4490	1
36984555	7	BIOHAZARD MARK NO.5	10
34836120	9	SCREW FLAT M3X6 (SUS)	100
34841015	10	SCREW WITH WASHER (T0.5)M3X8	10
36791672	11	ROLLER CATCHER C-128	1
34445944	12	HINGE TH-10-B-N (2126) LEFT	1

COVER_ASSY NO.208(XP-100)

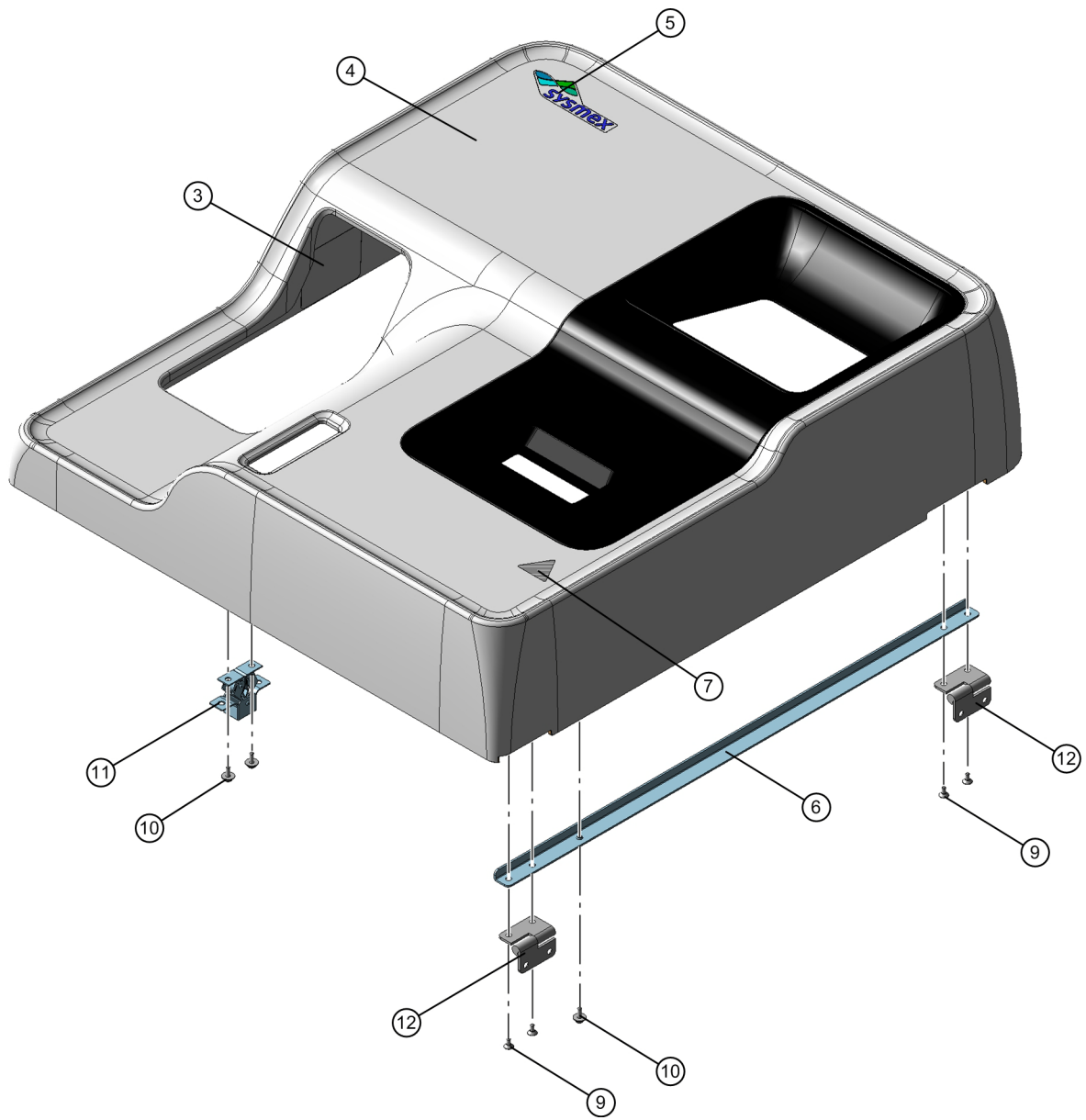

Code No.	Item No.	Description	Unit Q'ty
BW849940		COVER_ASSY NO.208(XP-100)	
36884863	3	SHEET NO.34	1
CK266123	4	COVER NO.2869	1
BP777121	6	MOUNT NO.4490	1
36984555	7	BIOHAZARD MARK NO.5	10
34836120	9	SCREW FLAT M3X6 (SUS)	100
34841015	10	SCREW WITH WASHER (T0.5)M3X8	10
36791672	11	ROLLER CATCHER C-128	1
34445944	12	HINGE TH-10-B-N (2126) LEFT	1

WIRING CORDS

Code No.	Description	Unit Q'ty
97330611	WIRING CORD NO.2357	1
97330719	WIRING CORD NO.2358	1
BS406358	WIRING CORD NO.7231	1
01322228	WIRING CORD NO.3147(350MM)	1
01322339	WIRING CORD NO.3148	1
97331218	WIRING CORD NO.2363	1
97331315	WIRING CORD NO.2364	1
CH811335	WIRING CORD NO.7226	1
97332022	WIRING CORD NO.2371(130MM)	1
01322010	WIRING CORD NO.3145	1
97331811	WIRING CORD NO.2369	1
BA163620	WIRING CORD NO.7230	1
97331811	WIRING CORD NO.2359	1
02308215	WIRING CORD NO.3260	1
97330816	WIRING CORD NO.2359	1
97330514	WIRING CORD NO.2356	1
99337017	WIRING CORD NO.2996	1

HYDRAULIC PARTS

Code No.	Description	Unit Q'ty
26663064	BUSH FREE SIZE CE-016	5
26664552	CLAMP FCN-6010	5
26671369	COIL TUBE SPP-08	1
26697754	SHIELD TAPE 10-TW-01030	1
34454876	FIXING SCREW NO. 18	10
34839112	SCREW BINDING M3X4 (SUS)	100
34885122	NUT HEX M2 (SUS)	100
34895126	WASHER SPRING M2 (SUS)	100
42613013	SEALING TAPE	5
44232721	FLUID CONNECTOR NO.29	1
44232735	FLUID CONNECTOR NO.30	1
44232988	RUBBER JOINT 8	10
44234243	HYDRAULIC CONNECTOR NO.14	10
44234306	HYDRAULIC CONNECTOR NO.20	10
44234310	HYDRAULIC CONNECTOR NO.21	10
44234323	HYDRAULIC CONNECTOR NO.22	10
44234337	HYDRAULIC CONNECTOR NO.23	10
44241459	FITTING BN-6 X 4 X PT 1/8 BSN	5
44253387	TUBE POLYURETHANE 4MMIDX6MMOD	25
44255166	TUBE JUNLON 4MMID X 6MMOD	10
44285039	TUBING NO.103	1
44302409	ORIFICE NO.40	1
44915082	SILENCER SLW-8A (SL-1/4)	1
83312211	NON-RETURN VALVE NO. 2	1
97345817	KX-II SHIELD TUBE ASSY	1
CH064778	THERMAL PROTECTOR UP72-70-015	1

PM PARTS LIST

Code No.	Item No.	Description	Unit Qty
AN809372		XP series PMPARTS_LIST	-
AB783677	1	DETECTOR_ASSY(PM) NO.11	1
AV258119	2	PRINTING PAPER_NO.3/5P COMPLETE	1
A BQ518368	4	SNS-C1103001 COVER SENSOR	1
BR302348	5	XP-100 IFU CD-ROM(PM)	1
CX019719	6	XP-100 IFU CD-ROM	1
AM311165	7	XP-300 IFU CD-ROM(PM)	1
BG376590	8	XP-300 IFU CD-ROM	1
AD283587	9	KIT NO.244	1
BH251346	10	KIT NO.245	1
B CM446969	11	PRINTER(PM) NO.1	1

312E003: Added the PM Parts List.

A 312G034 B 312K053

APPENDIX A SCHEMATICS

XP100_300 Wiring Diagram	A-1
XP100_300 Tubing Diagram	A-2
XP100_300 Hydraulic Diagram	A-3
XP100_300 Timing Chart-1 (Whole Blood Mode Analysis sequence)	A-4
XP100_300 Timing Chart-2 (Initial Start-Up Sequence)	A-5
XP100_300 Timing Chart-3 (PU Timer Sequence)	A-6
XP100_300 Timing Chart-4 (Mode Switch Sequence)	A-7
XP100_300 Timing Chart-5 (Detector Block Cleaning Sequence)	A-8
XP100_300 Timing Chart-6 (Gain Adjustment(WBC/RBC) Sequence)	A-9
XP100_300 Timing Chart-7 (Setting Sequence (Prime))	A-10
XP100_300 Timing Chart-8 (Shipping Sequence (Deprime))	A-11

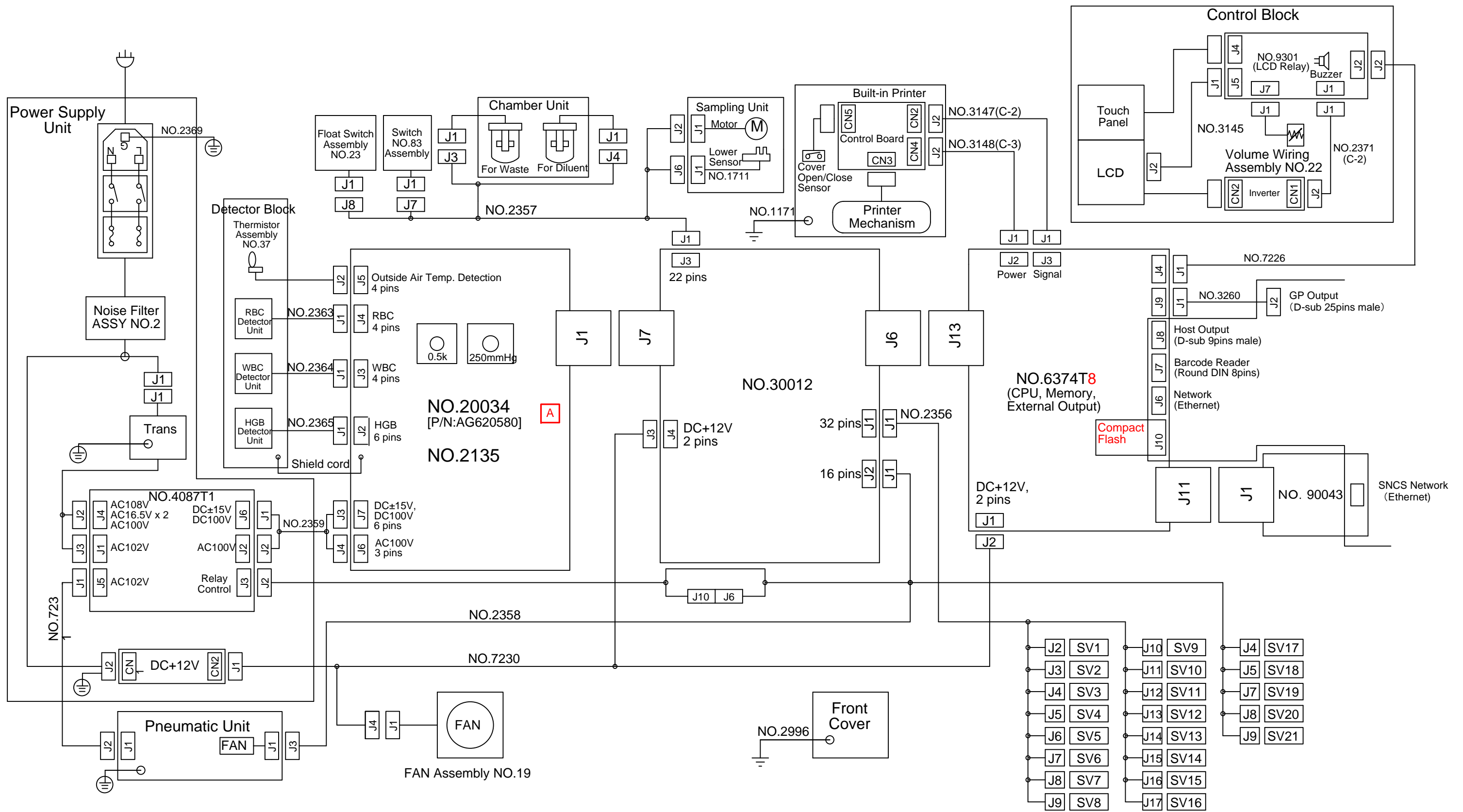

XP-100_300 Wiring Diagram

In regards to text written in red, refer to TB201297 for details of changes.

PCB NO.20034 added by ECR312J003. A

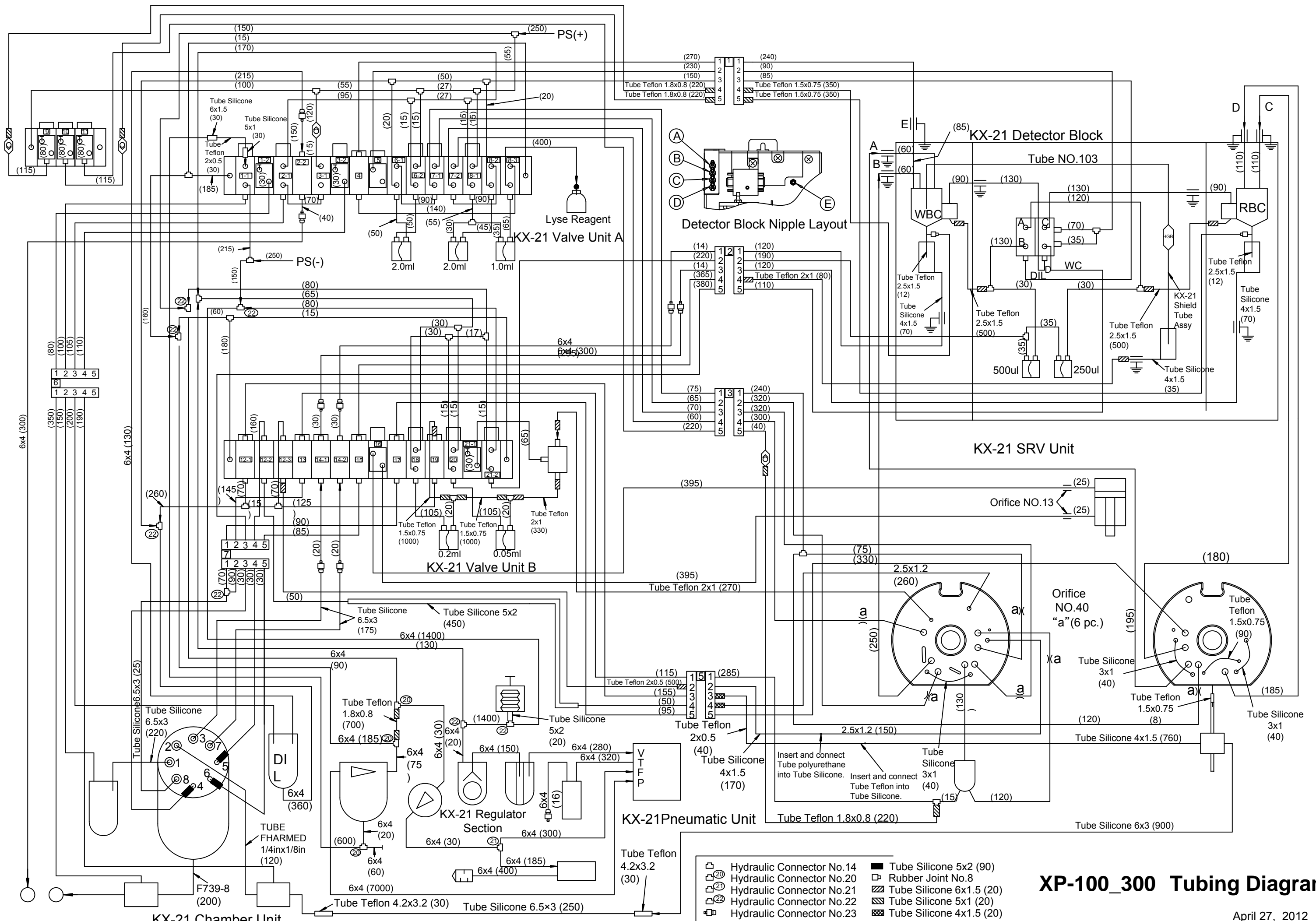

- | | | | |
|--|---------------------------|--|--------------------------|
| | Hydraulic Connector No.14 | | Tube Silicone 5x2 (90) |
| | Hydraulic Connector No.20 | | Rubber Joint No.8 |
| | Hydraulic Connector No.21 | | Tube Silicone 6x1.5 (20) |
| | Hydraulic Connector No.22 | | Tube Silicone 5x1 (20) |
| | Hydraulic Connector No.23 | | Tube Silicone 4x1.5 (20) |

XP-100_300 Tubing Diagram

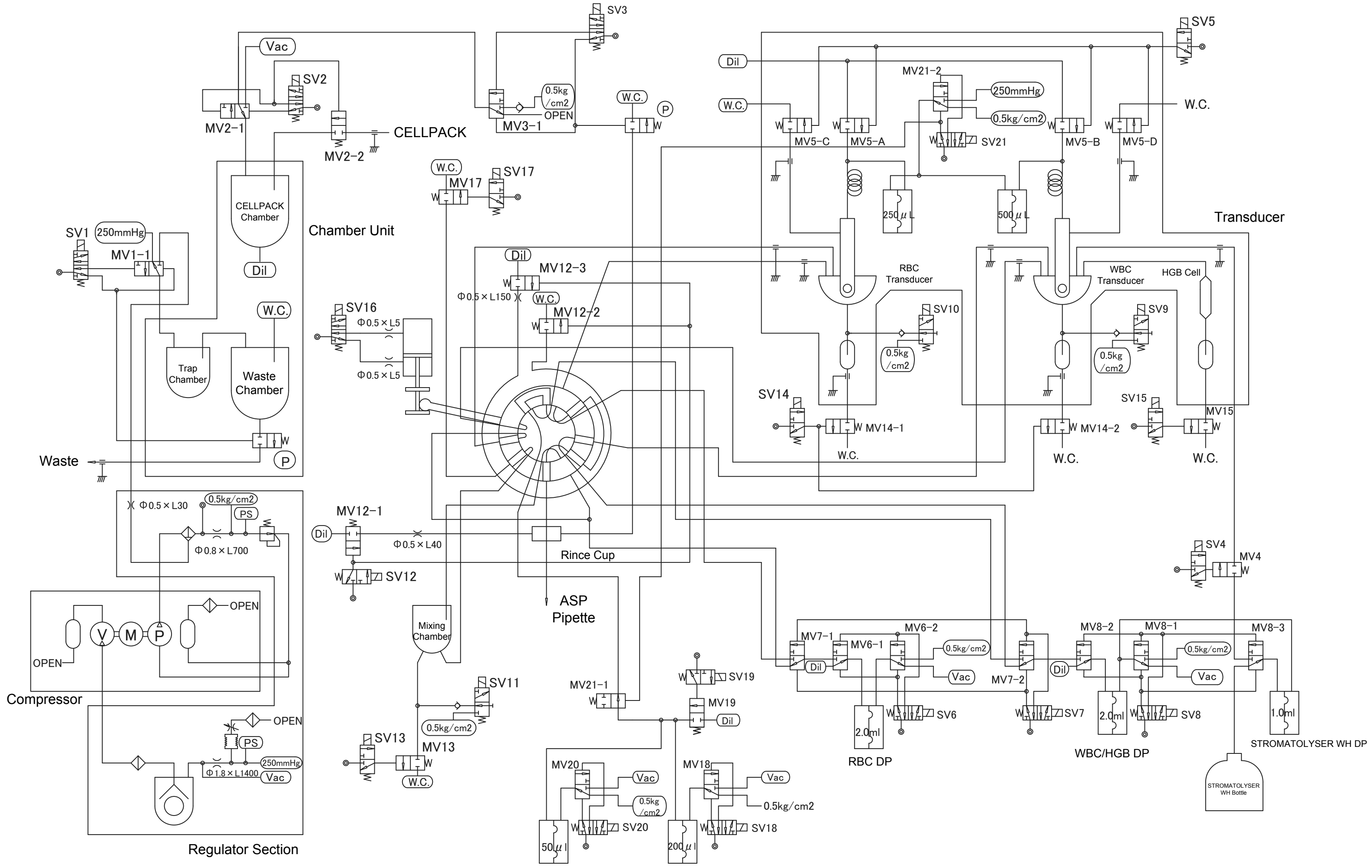

XP-100_300 Hydraulic Diagram

April 27, 2012
A-3

WB Mode WB Asp. DP Dilution Mode Dilution ASP. DP

Whole Blood Mode Analysis sequence

Basic Sequence

Sequence NO.	1	2	3	4	5	6	7	8	9	10
Function	WB Asp.	External Rinse	External Rinse	External Rinse	Internal Rinse	Internal Rinse	Counting	Counting	Counting	Counting
Sample Pipette	WB Asp.	External Rinse	External Rinse	External Rinse	Internal Rinse	Internal Rinse	Counting	Counting	Counting	Counting
Rinse Cup		External Rinse	External Rinse	External Rinse	Internal Rinse	Internal Rinse	Counting	Counting	Counting	Counting
SRV		Turn	Turn	Turn	Invert	Invert	Turn	Turn	Invert	Invert
MIX Chamber	Drain	Dil. Mix	Dil. Mix	Dil. Mix	Dil. Mix	Dil. Mix	Counting	Counting	Counting	Counting
RBC	Drain	Dil. Mix	Dil. Mix	Dil. Mix	Dil. Mix	Dil. Mix	Counting	Counting	Counting	Counting
WBC	Fill	Dil. Mix	Dil. Mix	Dil. Mix	Dil. Mix	Dil. Mix	Counting	Counting	Counting	Counting
HGB										
CELLPACK Chamber										
Waste Chamber										

SV/Motor Operation

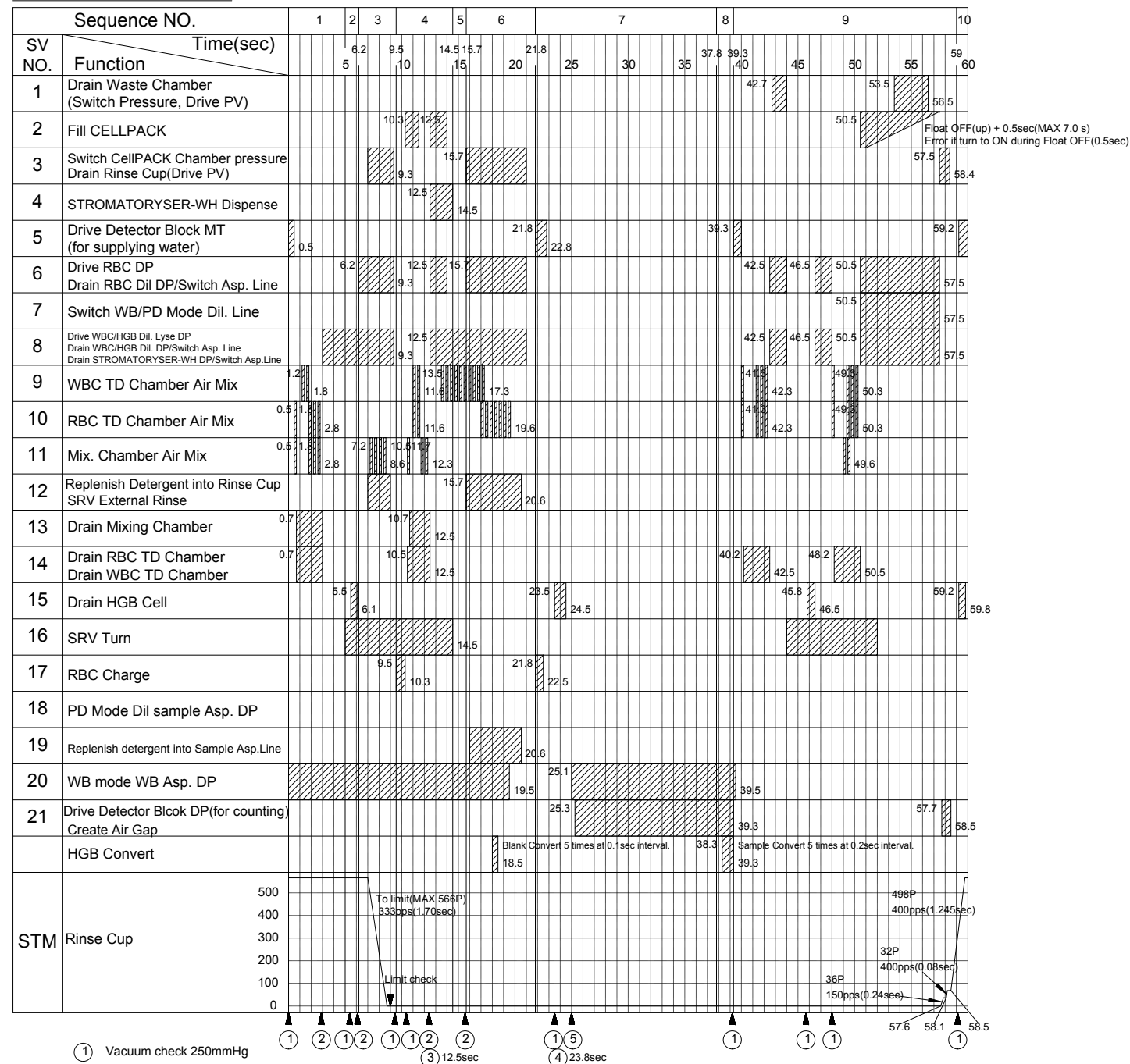

- ① Vacuum check 250mmHg
- ② Pressure Check 0.5kg/cm2
- ③ STROMATORYSER-WH Volume Check
- ④ Detector Block Temperature Check
- ⑤ Clog Monitor Check

Note)1. Operation of SV9 - 11(For mixing)is 0.2sec ON 0.2sec OFF.
 2. Sequence stop is available on Service Mode.
 3. It is recognized as an error when STROMATORYSER-WH is used approximately 95 times after the float switch is turned OFF(lower).

Pre-Diluted Mode Analysis Sequence

Basic Sequence

Sequence NO.	1	2	3	4	5	6	7	8	9	10
Function	WB Asp.	Substrate	External Rinse	External Rinse	Internal Rinse	Internal Rinse	Counting	Counting	Counting	Counting
Sample Pipette	WB Asp.	Substrate	External Rinse	External Rinse	Internal Rinse	Internal Rinse	Counting	Counting	Counting	Counting
Rinse Cup		External Rinse	External Rinse	External Rinse	Internal Rinse	Internal Rinse	Counting	Counting	Counting	Counting
SRV		Turn	Turn	Turn	Invert	Invert	Turn	Turn	Invert	Invert
MIX Chamber	Drain	Rinse	Rinse	Rinse	Rinse	Rinse	Counting	Counting	Counting	Counting
RBC	Drain	Rinse	Rinse	Rinse	Rinse	Rinse	Counting	Counting	Counting	Counting
WBC	Fill	Rinse	Rinse	Rinse	Rinse	Rinse	Counting	Counting	Counting	Counting
HGB										
CELLPACK Chamber										
Waste Chamber										

SV/Motor Operation

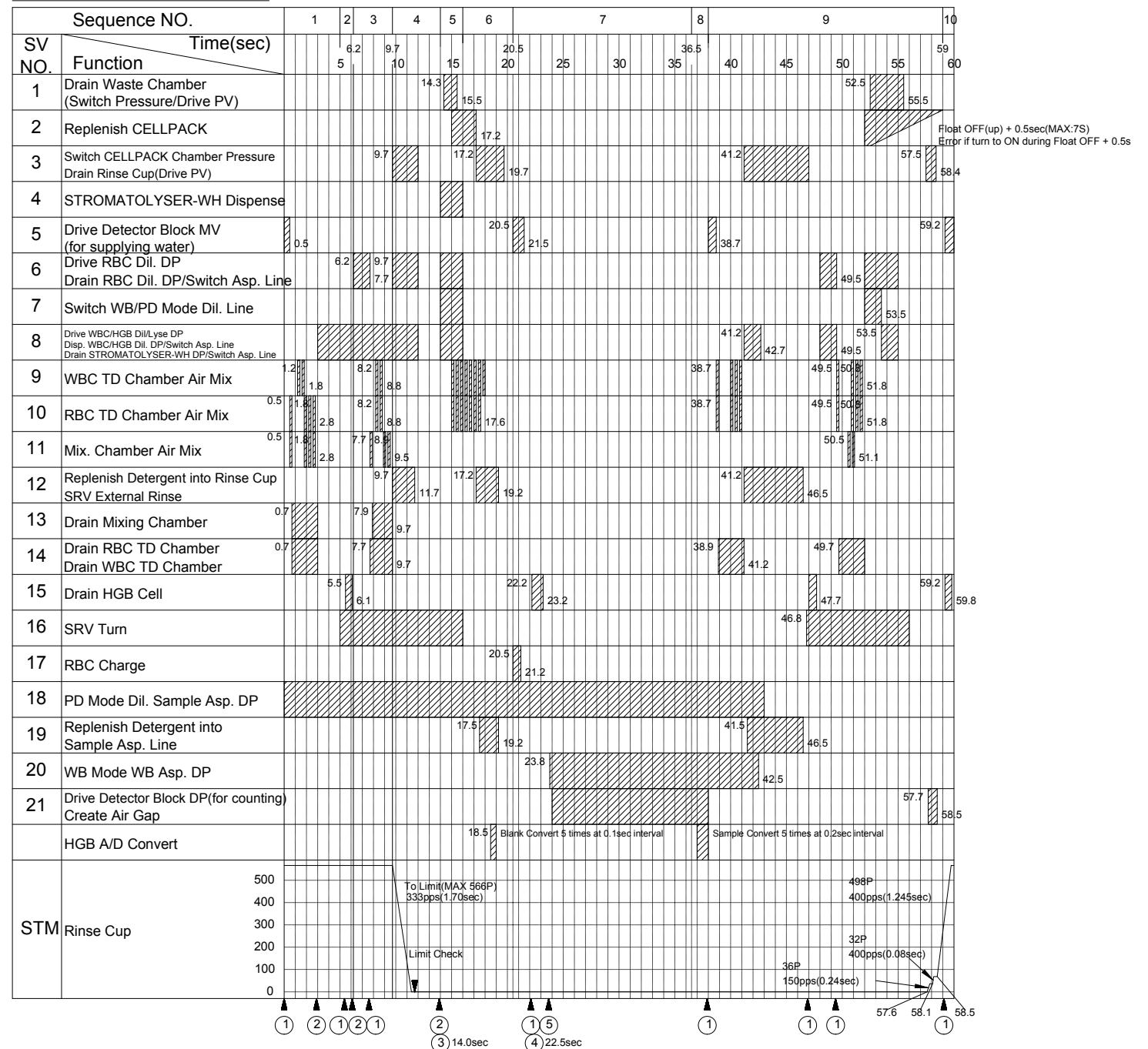

Initial Start-Up Sequence

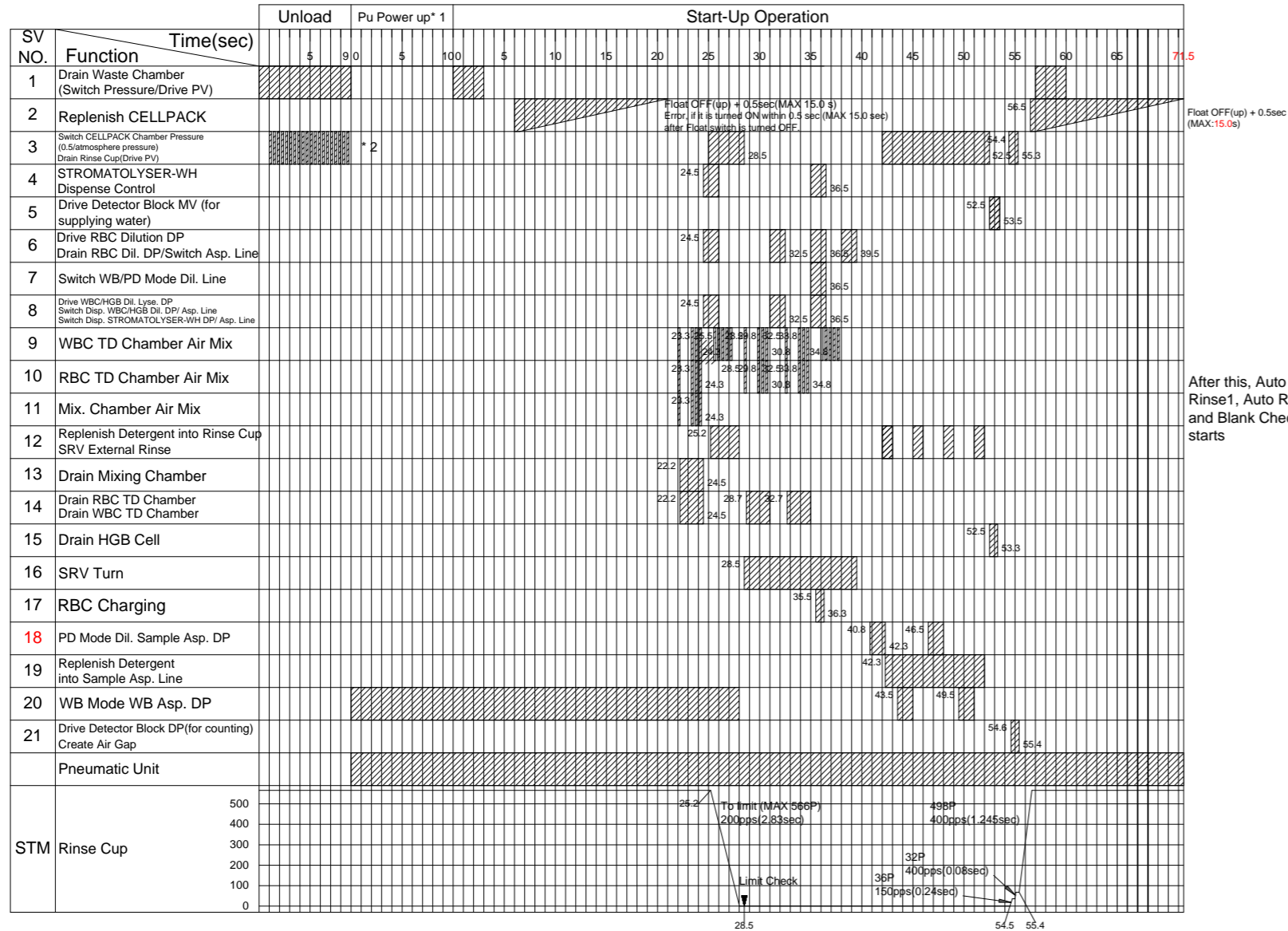

- *1 Completed when each pressure reaches the lowest pressure.
- *2 0.2sec ON 0.2sec OFF, repeat until 0.5kg/cm2 reaches 0.3kg/cm2 or lower.(MAX:20 times)
- Note)1. Operation of SV9-11(for mixing)is 0.2sec ON, 0.2sec OFF.

Auto Rinse Sequence

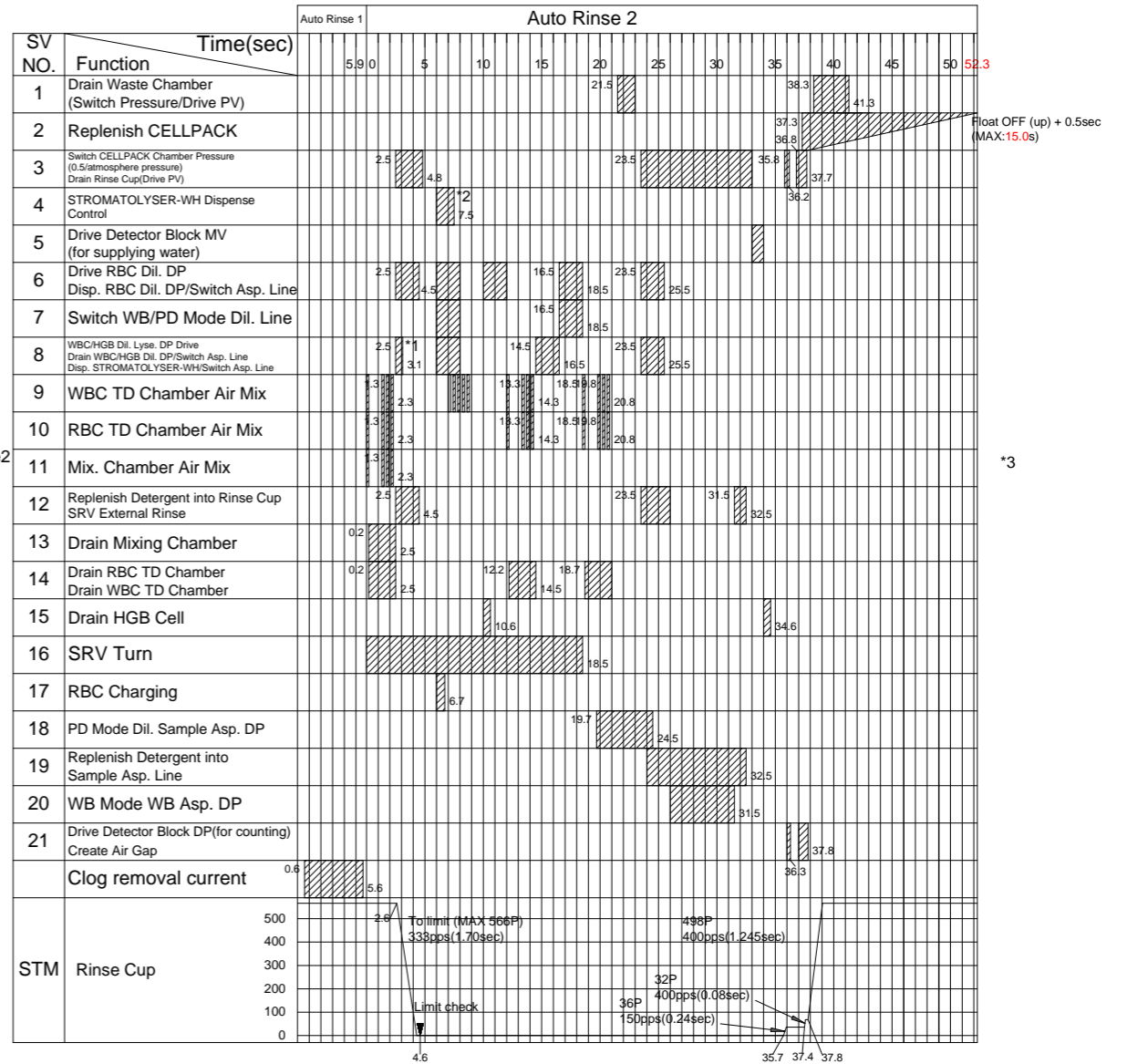

- *1 At the time of shut down, only 1st round of Auto Rinse 2 is performed after Initial Start-Up Sequence.
- *2 This is performed in every sequence except for *1 sequence.
- *3 Blank check starts after this.

Note) 1. Normally, Auto Rinse is performed in the following order: Auto Rinse1 -> Auto Rinse2 -> Auto Rinse2
 2. SV9 ~ 11 (For mixing) all operate in the following manner: (0.2 sec ON 0.2sec OFF)

Replace/Replenish Lyse-Reagent (STROMATOLYSER-WH) Sequence

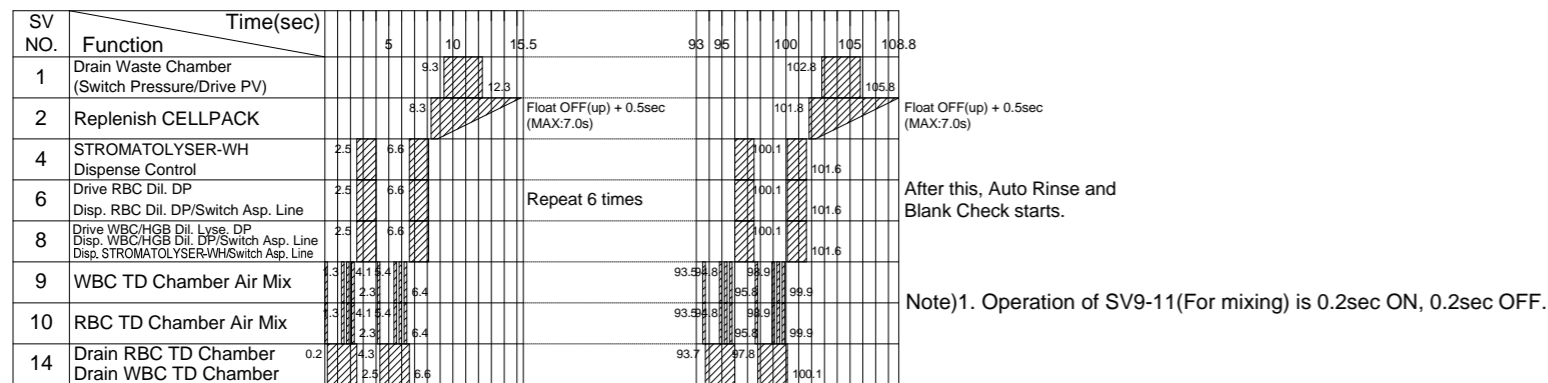

Replenish Dilution (CELLPACK) Sequence

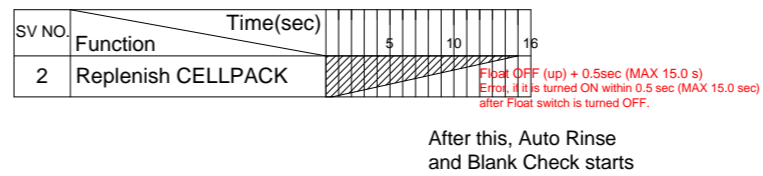

Waste Chamber Drain Sequence

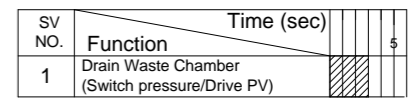

In regards to text written in red, refer to ECR 312C081 for details of changes.

PU Timer Sequence

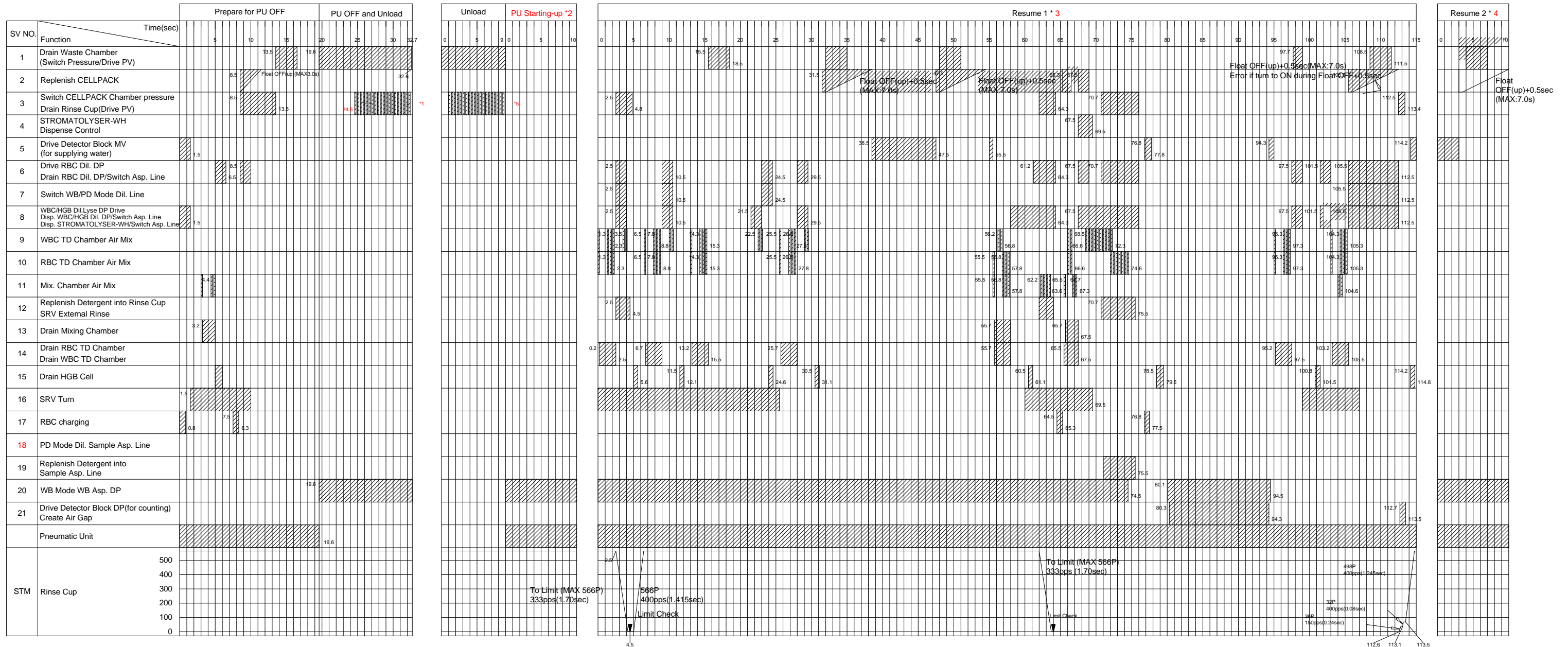

Notes) 1. Mode Switch sequence always operates after PU Starting-UP, Resume 1 and Resume 2.
 2. Operation of SV9-11 (For mixing) is 0.2sec ON, 0.2sec OFF.

Notes:

- * 1) 0.2sec ON, 0.2sec OFF
- * 2) Completed when each pressure reaches the lowest level.
- * 3) On only when is PU OFF is for more than 3 hours.
- * 4) On when PU is OFF (up to 3 hours)
- * 5) 0.2sec ON, 0.2sec OFF, repeat until 0.5kg/cm2 reaches 0.3kg/cm2 or lower. (Max:20 times)

In regards to text written in red, refer to ECR 312C081 for details of changes.

Mode Switch Sequence

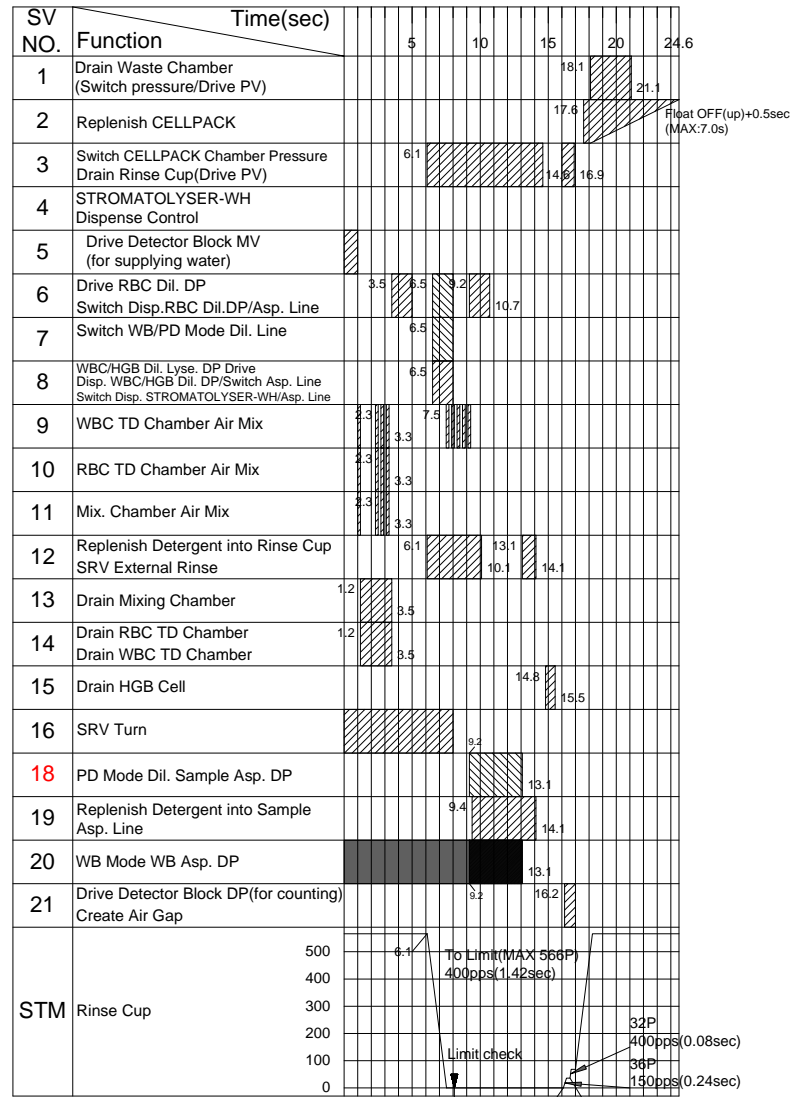

Operates only when WB mode is switched to PD Mode

Operates only when PD mode is switched to WB Mode.

Operates only when returning from sleep mode

Note) 1. Operation of SV9-11(For mixing) is 0.2sec ON, 0.2sec OFF.

Brush Cleaning Sequence

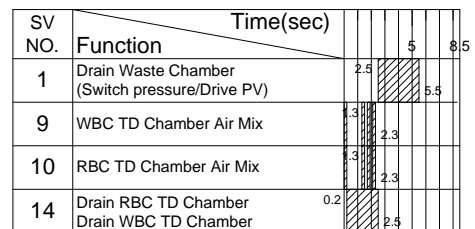

Note) 1. Operation of SV9-10(for mixing) is 0.2sec ON, 0.2sec OFF.

Shutdown Sequence

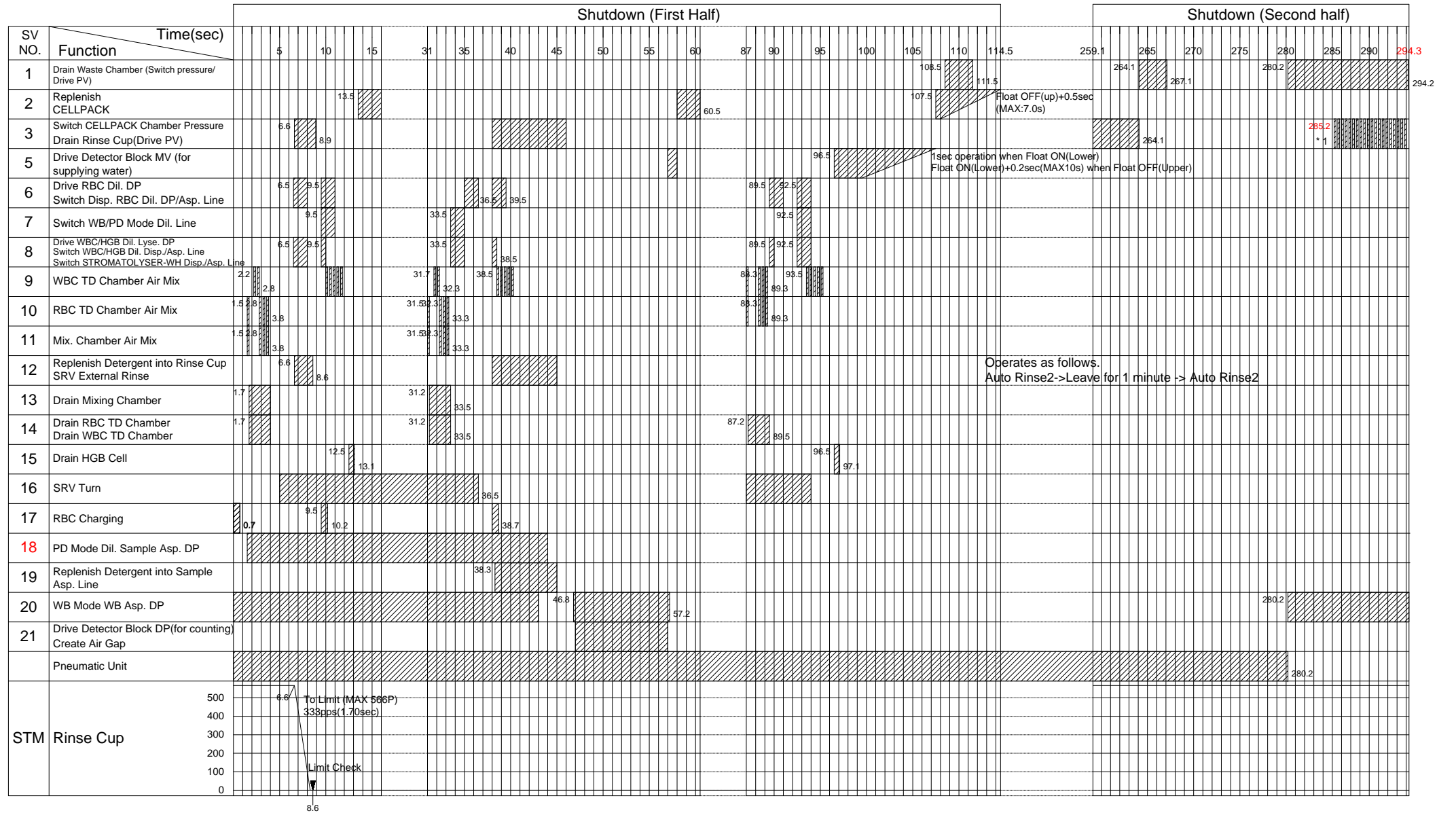

Note) 1. Operation of SV9-11(for mixing) is 0.2sec ON, 0.2sec OFF.

*1 0.2sec ON, 0.2sec OFF

Diaphragm Pump Test Sequence

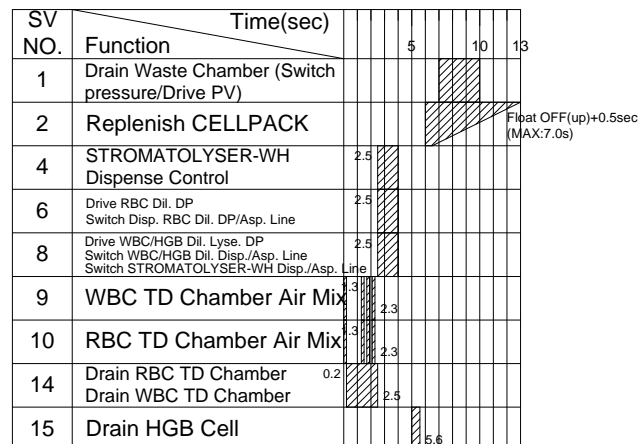

Note) 1. Operation of SV9-10 (for mixing) is 0.2sec ON, 0.2sec OFF.

In regards to text written in red, refer to ECR 312C081 for details of changes.

Detector Block Cleaning Sequence

SV NO.	Function	Time(sec)
1	Drain Waste Chamber (Switch Pressure/Drive PV)	5
2	Replenish CELLPACK	
5	Drive Detector Block MV (for supplying water)	
6	Drive RBC Dil. DP Switch RBC Dilution Dispense/Asp. Line	
8	Drive WBC/HGB Dil. Lyse. DP Switch WBC/HGB Dil. Disp./Asp. Line Switch STROMATOLYSER-WH Disp./Asp. Line	
9	WBC TD Chamber Air Mix	2.3
10	RBC TD Chamber Air Mix	2.3
14	Drain RBC TD Chamber Drain WBC TD Chamber	0.2
15	Drain HGB Cell	2.5
21	Drive Detector Block DP(for counting) Create Air Gap	
	Burn(Aperture AC 100V)	

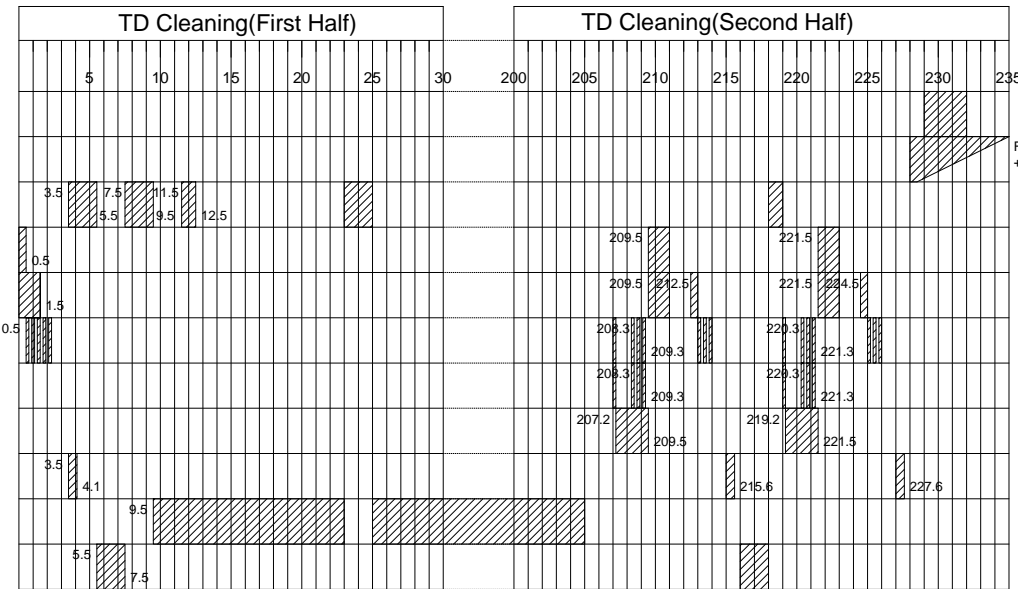

Note) 1. Operation of SV9-10(for mixing) is 0.2sec ON, 0.2sec OFF.

Recovery Sequence when TD Cleaning Brush Cleaning Sequences are suspended.

SV NO.	Function	Time(sec)
1	Drain Waste Chamber (Switch Pressure/Drive PV)	6.5
2	Replenish CELLPACK	9.5
5	Drive Detector Block MV (for supplying water)	
6	Drive RBC Dil. DP Switch RBC Dilution Dispense/Asp. Line	1.5
8	Drive WBC/HGB Dil. Lyse. DP Switch WBC/HGB Dil. Disp./Asp. Line Switch STROMATOLYSER-WH Disp./Asp. Line	1.5
15	Drain HGB Cell	5.6

Clog Removal Sequence

SV NO.	Function	Time(sec)
1	Drain Waste Chamber (Switch Pressure/Drive PV)	18.5
2	Replenish CELLPACK	21.5
5	Drive Detector Block MV (for supplying water)	
6	Drive RBC Dil. DP Switch RBC Dilution Dispense/Asp. Line	13.5
8	Drive WBC/HGB Dil. Lyse. DP Switch WBC/HGB Dil. Disp./Asp. Line Switch STROMATOLYSER-WH Disp./Asp. Line	0.5
9	WBC TD Chamber Air Mix	9.5
10	RBC TD Chamber Air Mix	9.5
14	Drain RBC TD Chamber Drain WBC TD Chamber	9.7
15	Drain HGB Cell	17.6
21	Drive Detector Block DP(for counting) Create Air Gap	3.5
	Burn(Aperture AC 100V)	1.1

In the execution due to an error recovery, Auto Rinse Blank Check starts after this. In the execution by menu select, they do not start.

Note) 1. Operation of SV9-10(for mixing) is 0.2sec ON, 0.2sec OFF.

Waste Chamber Rinse Sequence

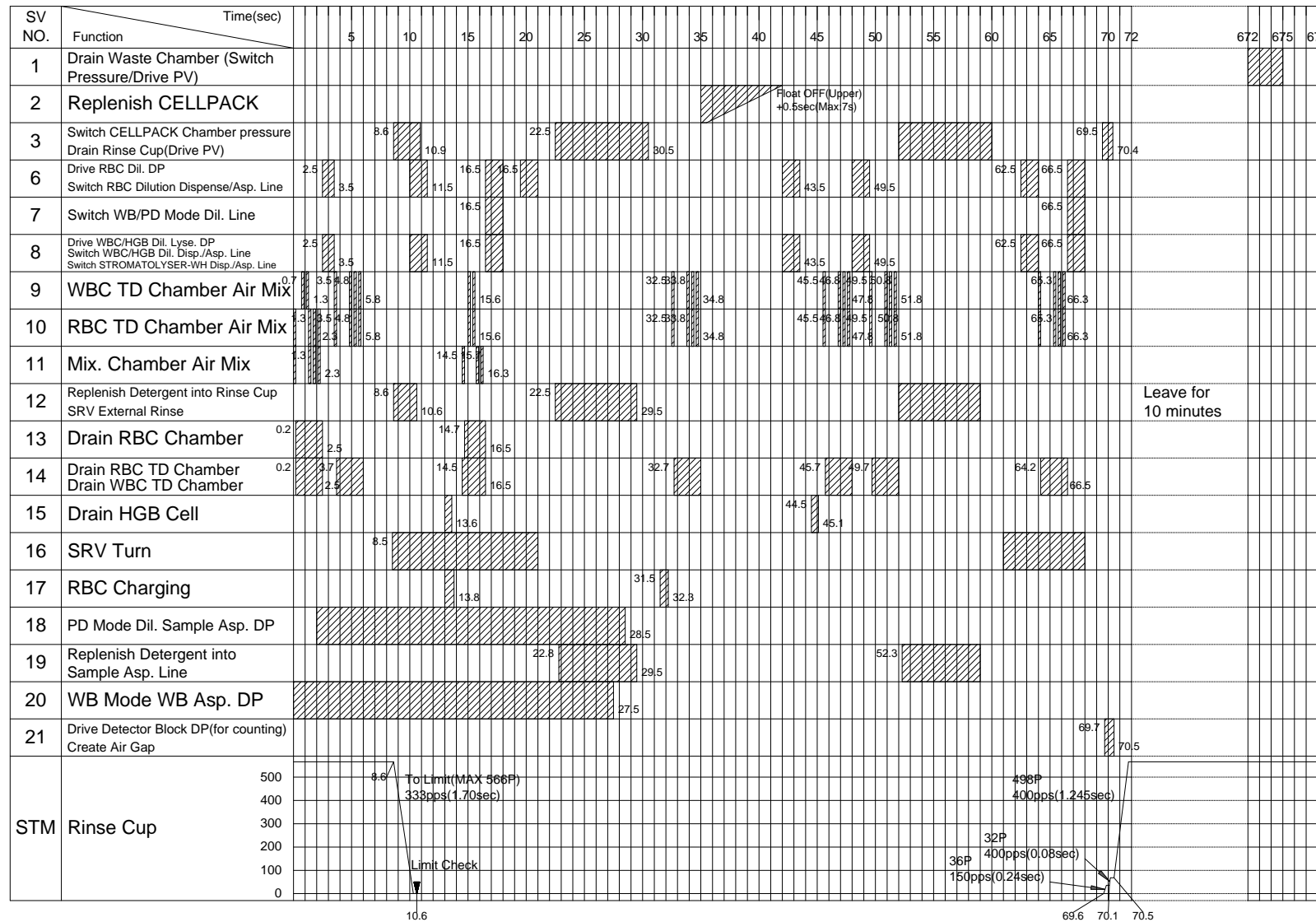

Note) 1. Operation of SV9-11(for mixing) is 0.2sec ON, 0.2sec OFF.

Gain Adjustment(WBC/RBC) Sequence

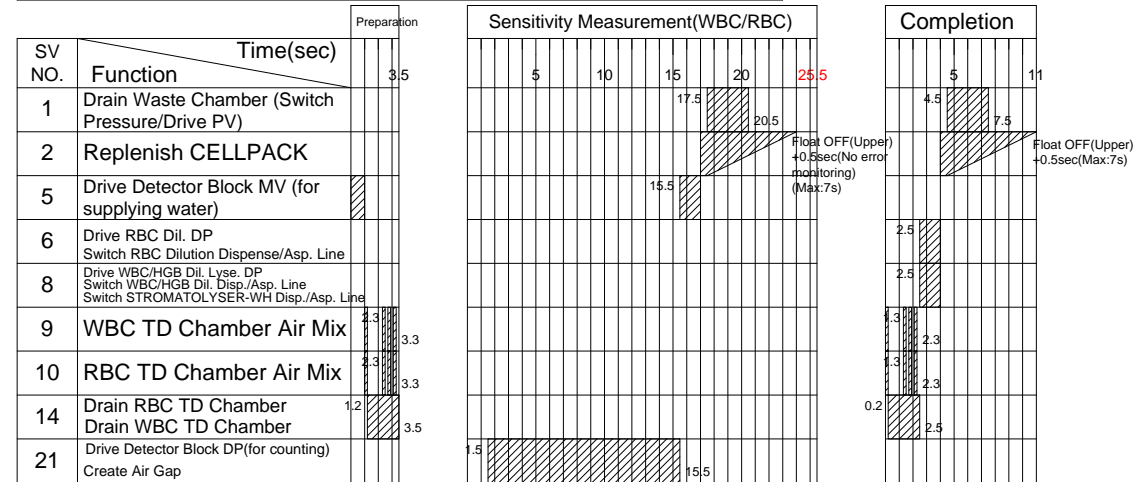

Note) 1. Operation of SV9-10(for mixing) is 0.2sec ON, 0.2sec OFF.

Gain Adjustment (PLT) Sequence

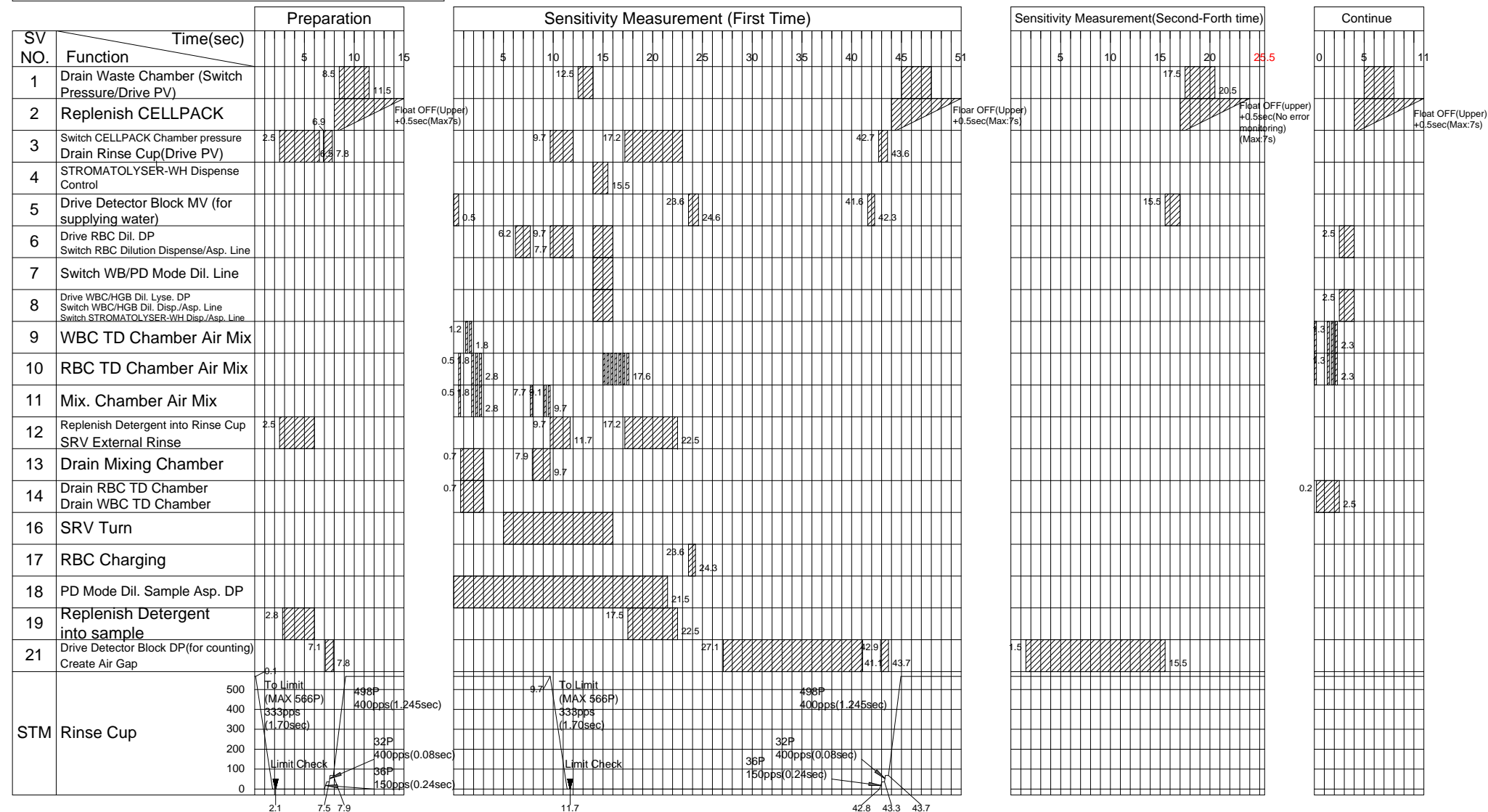

Note)1. Auto Rinse2 operates when completed.

2. Operation of SV9-11(For Mixing) is 0.2sec ON, 0.2sec OFF.

In regards to text written in red, refer to ECR 312C081 for details of changes.

Setting Sequence

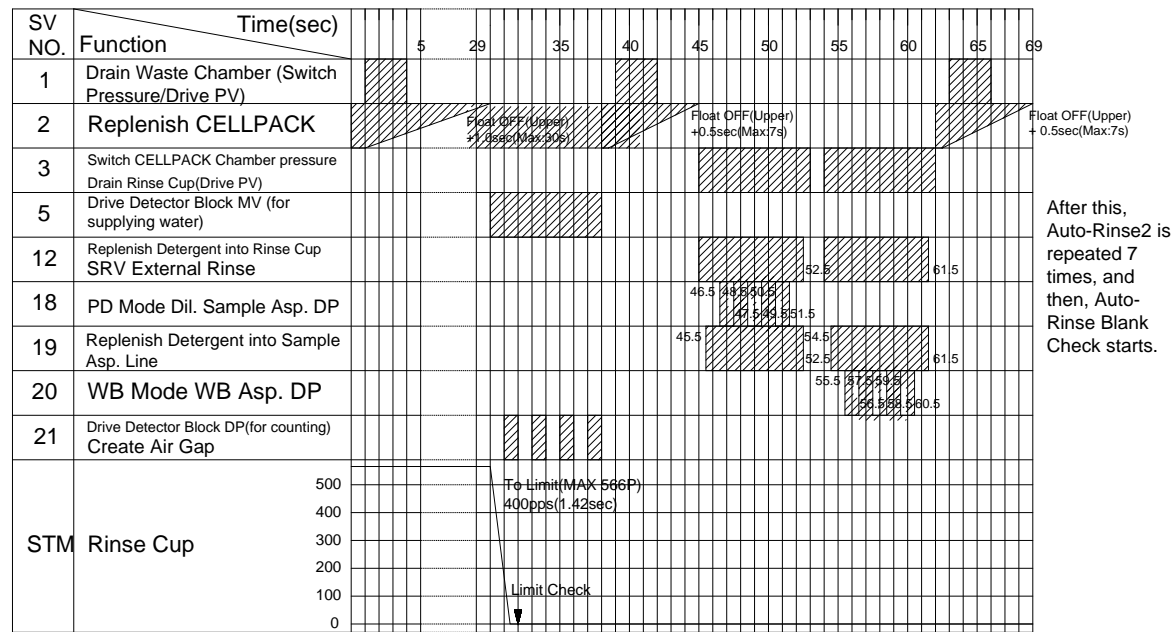

Water Filling Sequence in Production Mode

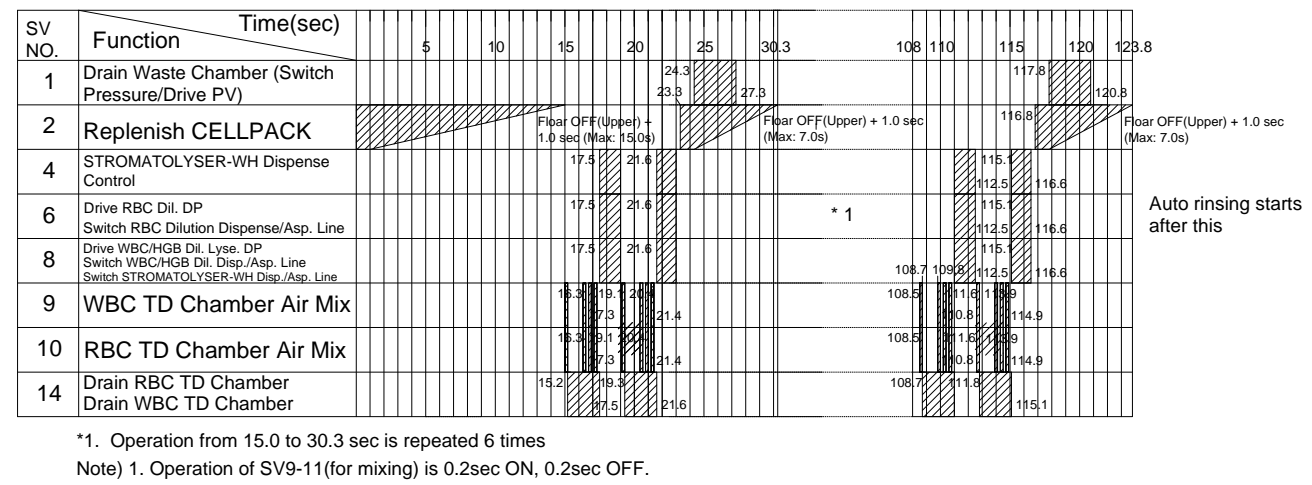

Depriming Sequence

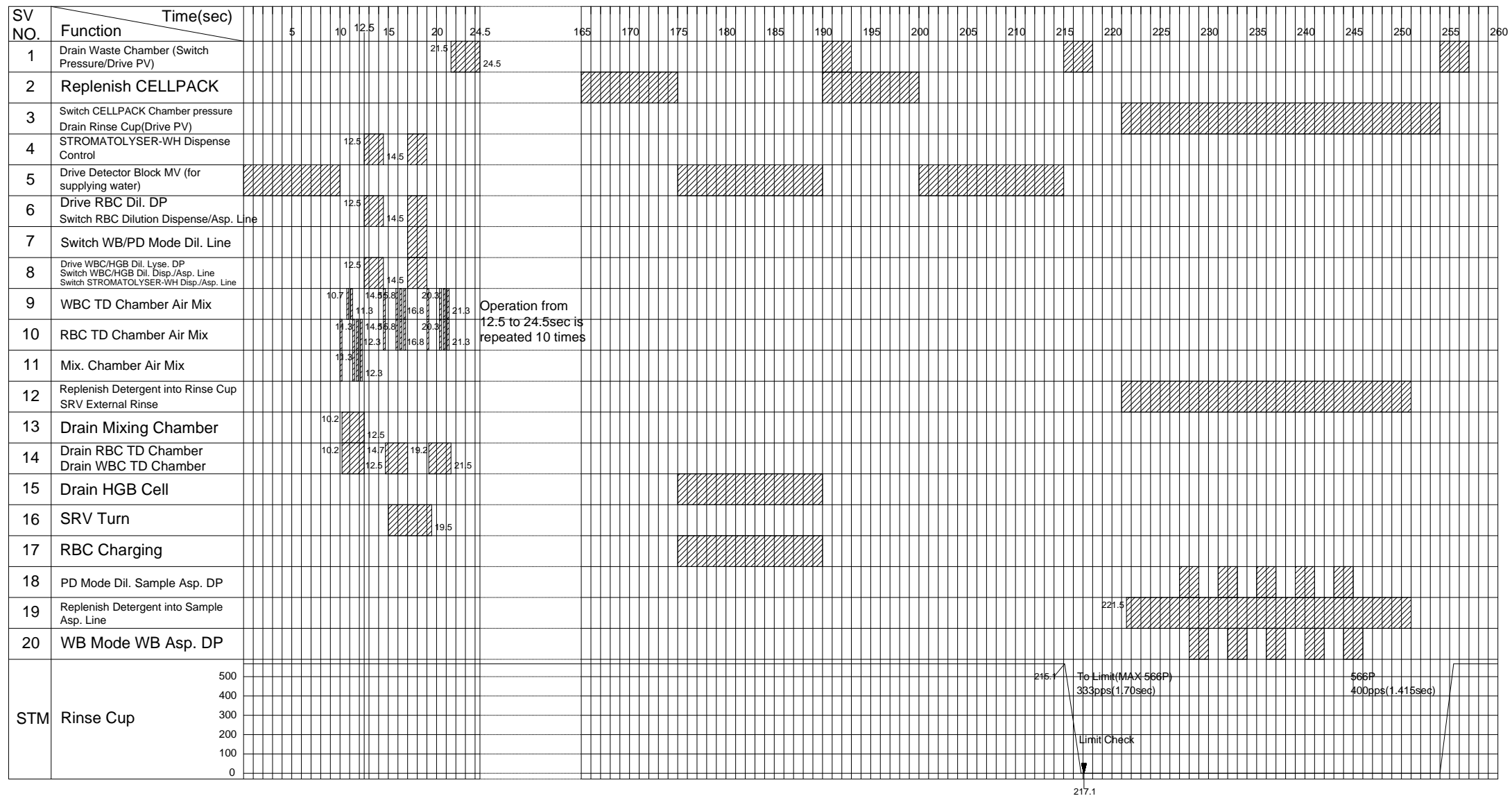

Note) 1. Operation of SV9-11(for mixing) is 0.2sec ON, 0.2sec OFF.

Shipping Sequence

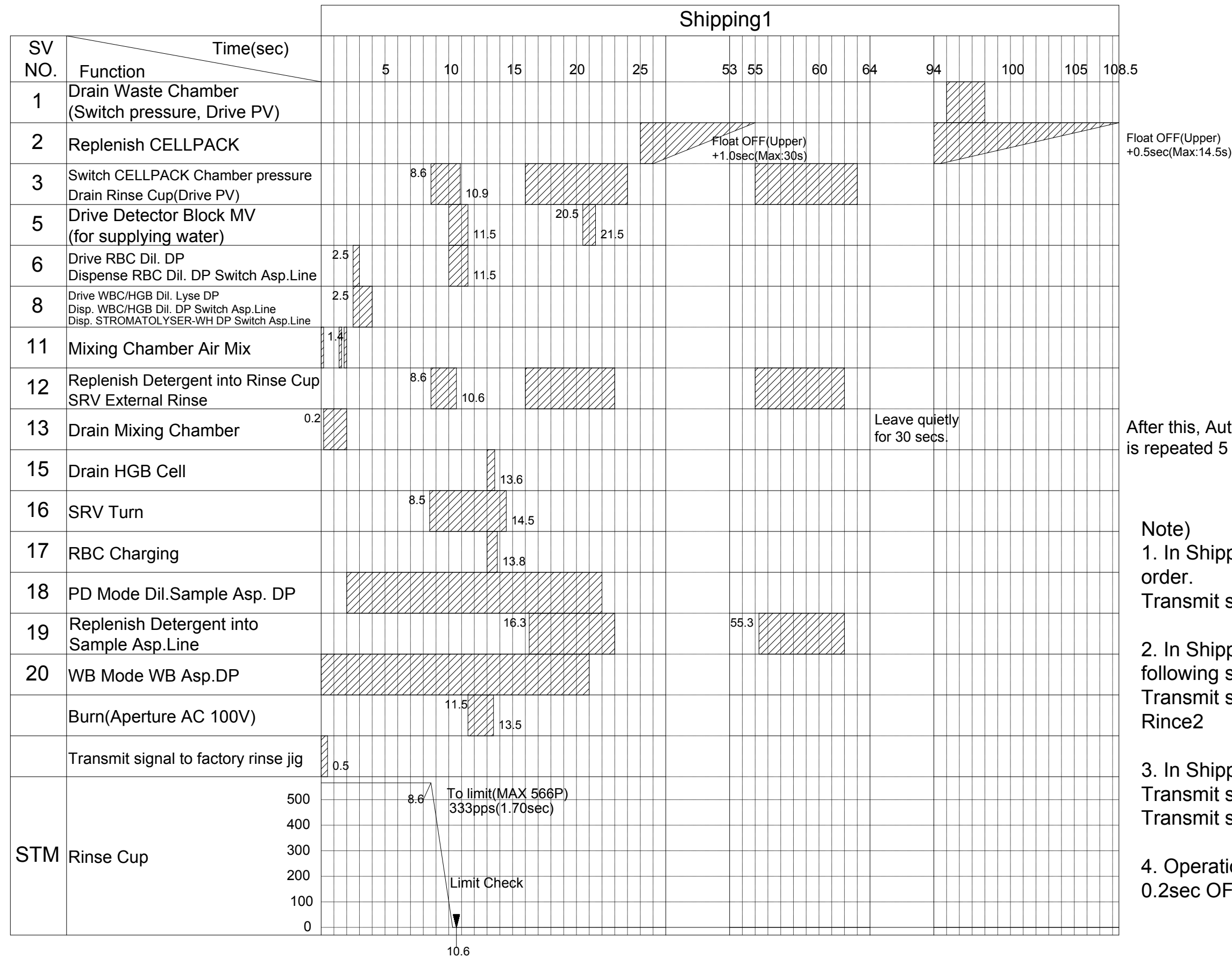

Float OFF(Upper)
+0.5sec(Max:14.5s)

Leave quietly
for 30 secs.

After this, Auto-Rinse2
is repeated 5 times.

Note)

1. In Shipping 2, the process operates in following order.
Transmit signal to shipping jig -> De-priming

2. In Shipping 3 (RO water rinse), it repeats 7 times following sequence.
Transmit signal to shipping jig -> Installation -> Auto Rinse2

3. In Shipping 4, it operates as following process.
Transmit signal to shipping jig -> De-priming -> Transmit signal to shipping jig

4. Operation of SV11(For Mixing) is 0.2sec ON
0.2sec OFF.

Pressure Convert Table

For pressure converted values, please refer to the below table.

If not listed, please calculate using below formula (1) or (2).

(1) Vacuum y (MPa) = x (mmHg) * 0.000133322

(2) Pressure (MPa) = X (kg/cm²) * 0.0980665

Vacuum non SI unit (x)	Vacuum SI unit (y)	Pressure non SI unit (X)	Pressure SI unit (Y)
5 mmHg	0.0007 MPa	0.001 kg/cm ²	0.0001 MPa
10 mmHg	0.0013 MPa	0.003 kg/cm ²	0.0003 MPa
20 mmHg	0.0027 MPa	0.005 kg/cm ²	0.0005 MPa
35 mmHg	0.0047 MPa	0.01 kg/cm ²	0.0010 MPa
100 mmHg	0.0133 MPa	0.03 kg/cm ²	0.0029 MPa
150 mmHg	150 MPa	0.05 kg/cm ²	0.0049 MPa
180 mmHg	0.0240 MPa	0.07 kg/cm ²	0.0069 MPa
200 mmHg	0.0267 MPa	0.1 kg/cm ²	0.0098 MPa
215 mmHg	0.0287 MPa	0.2 kg/cm ²	0.0196 MPa
220 mmHg	0.0293 MPa	0.25 kg/cm ²	0.0245 MPa
230 mmHg	0.0307 MPa	0.27 kg/cm ²	0.0265 MPa
240 mmHg	0.0320 MPa	0.300 kg/cm ²	0.0294 MPa
248 mmHg	0.0331 MPa	0.301 kg/cm ²	0.0295 MPa
250 mmHg	0.0333 MPa	0.33 kg/cm ²	0.0324 MPa
252 mmHg	0.0336 MPa	0.35 kg/cm ²	0.0343 MPa
260 mmHg	0.0347 MPa	0.380 kg/cm ²	0.0373 MPa
270 mmHg	0.0360 MPa	0.400 kg/cm ²	0.0392 MPa
280 mmHg	0.0373 MPa	0.43 kg/cm ²	0.0422 MPa
290 mmHg	0.0387 MPa	0.45 kg/cm ²	0.0441 MPa
298 mmHg	0.0397 MPa	0.47 kg/cm ²	0.0461MPa
299 mmHg	0.0399 MPa	0.497 kg/cm ²	0.0487 MPa
300 mmHg	0.0400 MPa	0.500 kg/cm ²	0.0490 MPa
380 mmHg	0.0507 MPa	0.510 kg/cm ²	0.0500 MPa
390 mmHg	0.0520 MPa	0.52 kg/cm ²	0.0510 MPa
400 mmHg	0.0533 MPa	0.53 kg/cm ²	0.0520 MPa
415 mmHg	0.0553 MPa	0.55 kg/cm ²	0.0539 MPa
420 mmHg	0.0560 MPa	0.57 kg/cm ²	0.0559 MPa
440 mmHg	0.0587 MPa	0.60 kg/cm ²	0.0588 MPa
450 mmHg	0.0600 MPa	0.605 kg/cm ²	0.0593 MPa
500 mmHg	0.0667 MPa	0.62 kg/cm ²	0.0608 MPa
510 mmHg	0.0680 MPa	0.622 kg/cm ²	0.0610 MPa
530 mmHg	0.0707 MPa	0.650 kg/cm ²	0.0637 MPa
550 mmHg	0.0733 MPa	0.665 kg/cm ²	0.0652 MPa
600 mmHg	0.0800 MPa	0.70 kg/cm ²	0.0686 MPa
		0.701 kg/cm ²	0.0687 MPa
		0.750 kg/cm ²	0.0735 MPa
		1.000 kg/cm ²	0.0981 MPa
		1.030 kg/cm ²	0.1010 MPa
		1.05 kg/cm ²	0.1030 MPa
		1.1 kg/cm ²	0.1079 MPa
		1.5 kg/cm ²	0.1471 MPa

		1.588 kg/cm ²	0.1557 MPa
		1.60 kg/cm ²	0.1569 MPa
		1.601 kg/cm ²	0.1570 MPa
		1.7 kg/cm ²	0.1667 MPa
		1.80 kg/cm ²	0.1765 MPa
		1.9 kg/cm ²	0.1863 MPa
		2.000 kg/cm ²	0.1961 MPa
		2.010 kg/cm ²	0.1971 MPa
		2.1 kg/cm ²	0.2059 MPa
		2.15 kg/cm ²	0.2108 MPa
		2.200 kg/cm ²	0.2157 MPa
		2.240 kg/cm ²	0.2197 MPa
		2.25 kg/cm ²	0.2206 MPa
		2.30 kg/cm ²	0.2256 MPa
		2.4 kg/cm ²	0.2354 MPa
		2.492 kg/cm ²	0.2444 MPa
		2.5 kg/cm ²	0.2452 MPa
		2.513 kg/cm ²	0.2464 MPa
		2.533 kg/cm ²	0.2484 MPa
		2.7 kg/cm ²	0.2648 MPa
		2.8 kg/cm ²	0.2746 MPa
		3.0 kg/cm ²	0.2942 MPa